

Class XII Chemistry

CBSE Board, Set – 2

General Instructions:

- (i) All questions are compulsory.
- (ii) Q. no. 1 to 5 are very short answer questions and carry 1 mark each.
- (iii) Q. no. 6 to 10 are short answer questions and carry 2 mark each.
- (iv) Q. no. 11 to 22 are also short answer questions and carry 3 mark each.
- (v) Q. no. 23 is a value based question and carry 4 marks.
- (vi) Q. no. 24 to 26 are long answer questions and carry 5 marks each.
- (vii) Use long tables if necessary, use of calculators is not allowed.

Q1. Which one undergo S_N2 reaction faster in the following pair and why?

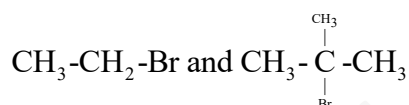

Sol.1

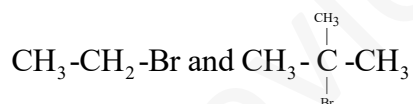

We know that for S_N2 reaction, the reactivity series is Primary > Secondary > Tertiary as the Steric Hinderance is less. Hence $\text{CH}_3\text{-CH}_2\text{-Br}$ will go faster.

Q2. Out of BaCl_2 and KCl , which one is more effective in causing coagulation of a negatively charged colloidal Sol? Give reason.

Sol.2 **According to Hardy Schulze law** Greater is the valency of the oppositely charged ion of the electrolyte being added, the faster is the coagulation.

Hence BaCl_2 is more effective

Q3. What is the formula of a compound in which the element Y from ccp lattice and atoms of X occupy $1/3^{\text{rd}}$ of tetrahedral voids?

Sol.3 Since element X are in ccp arrangement, the number of X per unit cell = 4

The number of tetrahedral void = 8

But only $1/3^{\text{rd}}$ is occupied by Y, therefore $8 \times 1/3 = 8/3$

Hence the formula of the compound is $X_4Y_{8/3} = X_{12}Y_8$ or X_3Y_2

Q4. What is basicity of H_3PO_4 ?

Sol.4

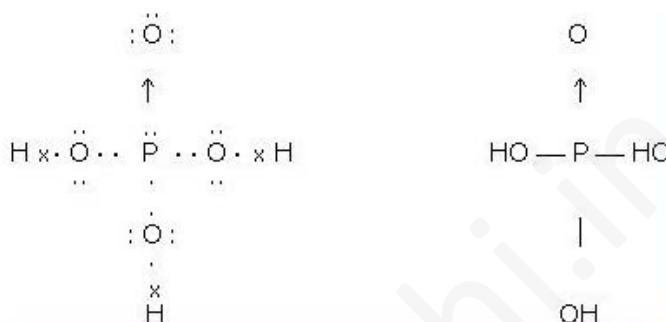

Due to this structure its basicity is 3 not 1... number of hydrogens directly attached to oxygen atom is basicity of any molecule...

Q5. Write the IUPAC name of the given compound:

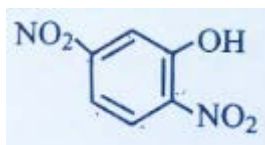
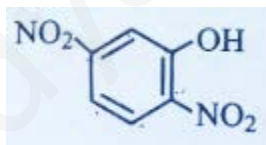

Sol.5 IUPAC Name: 2, 5 - dinitro phenol

Q6. Name of reagents used in the following reactions:

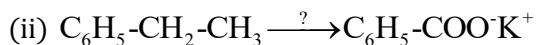
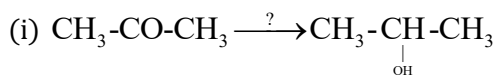

Sol.6 (i) $LiAlH_4$ & $NaBH_4$

(ii) $KMnO_4$

Q7. What is meant by positive deviations from Raoult's law? Give an example. What is the sign of $\Delta_{\text{mix}}H$ for positive deviation?

Sol.7 When the cohesive forces between like molecules are greater than the adhesive forces, the dissimilarities of polarity leads both components to escape solution more easily. Therefore, the vapor pressure is greater than expected from the Raoult's law, showing positive deviation. Some mixtures in which this happens are

(1) benzene and methanol, (2) carbon disulfide and acetone, and (3) chloroform and ethanol.

This reaction is endothermic reaction. For Endothermic reaction delta H is always positive.

OR

Q7. Define azeotropes. What type of azeotrope is formed by positive deviations from Raoult's law? Give an example.

Sol.7 An **azeotrope** is a mixture of two or more liquids whose proportions cannot be altered by simple distillation. This happens because, when an azeotrope is boiled, the vapor has the same proportions of constituents as the unboiled mixture.

Because their composition is unchanged by distillation, **azeotropes** are also called (especially in older texts) **constant boiling mixtures**.

Positive deviation from Raoult's law as azeotropes are :

(1) benzene and methanol, (2) carbon disulfide and acetone, and (3) chloroform and ethanol.

Q8. (a) Following reactions occur at cathode during the electrolysis of aqueous silver chloride solution:

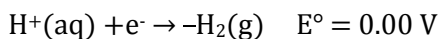
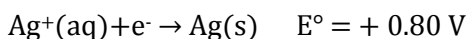

On the basis of their standard reduction electrode potential (E°) values. Which reaction is feasible at the cathode and why?

(b) Define limiting molar conductivity. Why conductivity of an electrolyte solution decreases with the decrease in concentration?

Sol.8 (a) At cathode, reduction takes place so for

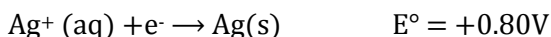

$$\Delta G = -nFE$$

So E is positive, $\Delta G = -ve$ hence spontaneous.

(b) **Molar conductivity:**

Molar conductivity of a solution at a given concentration is the conductance V of solution containing one mole of electrolyte kept between two electrodes with area of cross section A and distance of unit length. Therefore,

Distance is unit so $l = 1$

$$\text{Volume} = \text{area of base} \times \text{length}$$

$$\Lambda_m = kA/l$$

$$\Lambda_m = kV$$

Or

Molar conductivity increases with decrease in concentration. When concentration approaches zero, the molar conductivity is known as **limiting molar conductivity** and is represented by the symbol $E^\circ m$.

For Strong electrolytes, Λ increases slowly with dilution and can be represented by the equation:

$$\Lambda_m = E^\circ m^\circ - A c^{1/2}$$

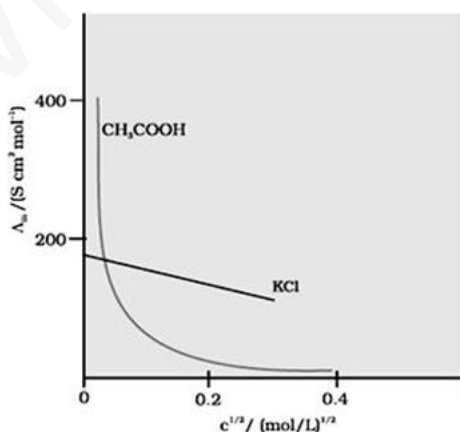

Molar conductivity versus $c^{1/2}$ for acetic acid (weak electrolyte) and potassium chloride (strong electrolyte) in aqueous solutions.

It can be seen that if we plot Λ_m against $c^{1/2}$, we obtain a straight line with intercept equal to E_m° and slope equal to $-A$. The value of the constant A for a given solvent and

temperature depends on the type electrolyte i.e., the charges on the cation and anion produced on the dissociation of the electrolyte in solution.

Q9. What are the transition elements? Write two characteristics of the transition elements.

Sol.9 The **transition elements** are those **elements** having a partially filled d or f subshell in any common oxidation state. The term "**transition elements**" most commonly refers to the d-block **transition elements**.

The following are the characteristics:

General Characteristics of Transition Elements

Metallic Character :

- All the transition elements are metals; this is because the number of electrons in outermost shell is only 2.
- Transition metals are hard, malleable and ductile due to presence of strong metallic bonds.
- Transition metals crystallize in all the three face centred cubic (fcc), hexagonal close packed (hcp) and body centred cubic (bcc) crystals.
- Transition metals of VIII and IB Groups are softer and more ductile as compare to the other transition metals.
- Along with metallic bonding, transition metals also show covalent bonding due to presence of unfilled d-orbitals.
- As transition elements are metals so they good conductors of heat and electricity.

Colour

Many compounds of transition elements are coloured in contrasts to those of s and p block elements. In compound state due to the surrounding groups (ligands), the d-orbitals of transition elements are not degenerate but split into two groups of different energy.

Thus it is possible to promote electrons from one group to another group. This corresponds to fairly small amount of energy difference and so light is absorbed in visible region. Compounds of transition metals are white for example $ZnSO_4$ and TiO_2 . In these compounds it is not possible to promote the electrons within the d – level.

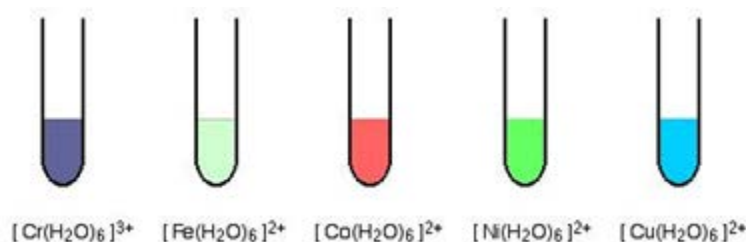

Q10. (i) Write down the IUPAC name of the following complex.

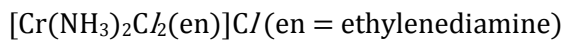

(ii) Write the formula for the following complex.

Pentaamminenitrito-o-Cobalt(III).

Sol.10 A. diamminedichloro ethylenediaminecobalt(III) chloride

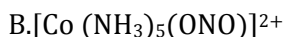

Q11. (i) Draw the geometrical isomers of complex $[\text{Pt}(\text{NH}_3)_2\text{Cl}_2]$.

(ii) On the basis of crystal field theory. Write the electronic configuration for d^4 ion if $\Delta_o < P$.

(iii) Write the hybridization and magnetic behavior of the complex $[\text{Ni}(\text{CO})_4]$.

(At.no. of Ni = 28).

Sol.11 (i)

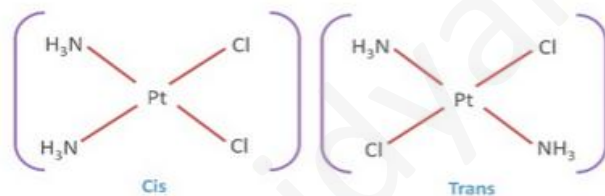

(ii) as the CFSE is $<$ Pairing energy, so no pairing will take place... so for d^4 ion, if ion is Tetrahedral then configuration will be $(d_{x^2-y^2})^2 (d_z)^2$ if ion is octahedral then configuration will be $(d_{xy})^2 (d_{yz})^1 (d_{xz})^1$

(iii) sp^3 hybridization and diamagnetic.

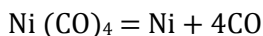

The valence shell electronic configuration of ground state Ni atom is $3d^8 4s^2$.

All of these 10 electrons are pushed into 3d orbitals and get paired up when strong field CO ligands approach Ni atom. The empty 4s and three 4p orbitals undergo sp^3 hybridization and form bonds with CO ligands to give $\text{Ni}(\text{CO})_4$ is diamagnetic.

Electronic configuration of Ni atom in ground state

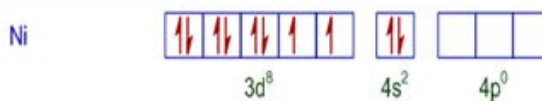

Change in electronic configuration of Ni atom when CO ligands approach it



Electronic configuration of Ni atom in $Ni(CO)_4$

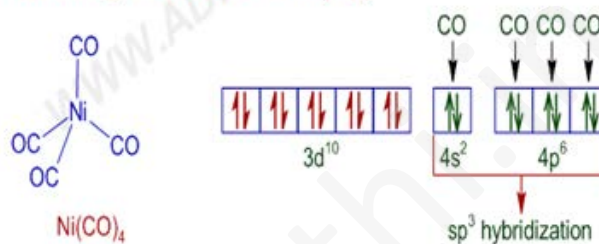

Q12. Calculate emf of the following cell at 25 °C:

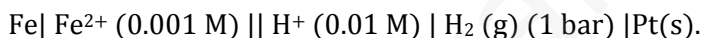

$E^\circ (Fe^{2+} | Fe) = -0.44 V$ $E^\circ (H_2) = 0.00 V$

Sol.12 $Fe | Fe^{2+}(0.001)m || H^+(0.01 m) | H_2(g)(1bar) | Pt(s)$

$E^\circ(Fe^{2+}/Fe) = -0.44 v$ $E^\circ (H^+|H_2) = 0.00 V$

$E_{cell} = E^\circ_{cell} - \frac{0.0591}{n} \log 2$

$E^\circ (Fe/Fe^{2+}) = - (-0.44) = 0.44$

$E = E^\circ_{cell} - \frac{0.0691}{n} \log \frac{[P]^2 [Fe^{2+}]}{[H^+]^2}$

$E = 0.44 - \frac{0.0591}{2} \log \frac{0.001}{(10^{-2})^2}$

$E = 0.44 - \frac{0.591}{2} \log 10^{-3} / 10^{-4}$

$E = 0.444 - \frac{0.0591}{2} \log 10$

$= 0.44 - 0.02955$

⇒ 0.41045

Q13. Give reason for the following observations:

- (i) Leather gets hardened after tanning.
- (ii) Lyophilic sol is more stable than lyophobic sol.
- (iii) It is necessary to remove CO when ammonia is prepared by haber's process.

Sol.13 (i) Animal hide is colloidal in nature and has positively charged particles. When it is soaked in tannin (negatively charged), a colloid, it results in Hardening of leather.

(ii) Lyophilic sols are relatively stable as strong forces of interaction exist between colloidal and liquid while lyophobic sols are less stable as weak forces of interaction exist between colloidal particles and liquid.

(iii) co-produced is an oxidizing agent it will react with ammonia thus reducing its yield co comes by reaction of hydrogen with air.

Q14. Write the names and structure of the monomers of the following polymers:

- (i) Nylon-6, 6
- (ii) PHBV
- (iii) Neoprene

Sol.14 (i) Nylon 6.6 is formed by the condensation of hexamethylene diamine with adipic acid.

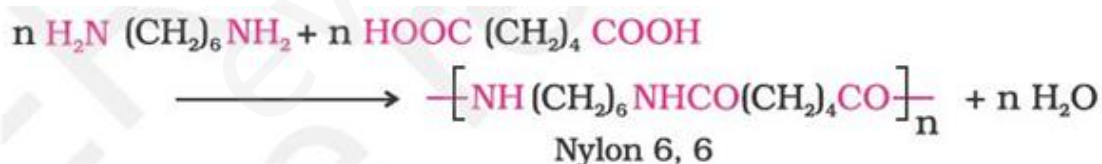

(ii) Poly β-hydroxybutyrate – co-β-hydroxy valerate (PHBV) It is obtained by the copolymerization of 3-hydroxybutanoic acid. PHBV is used in specialty packaging. Orthopaedic devices and in controlled release of drugs. PHBV undergoes bacterial degradation in the environment.

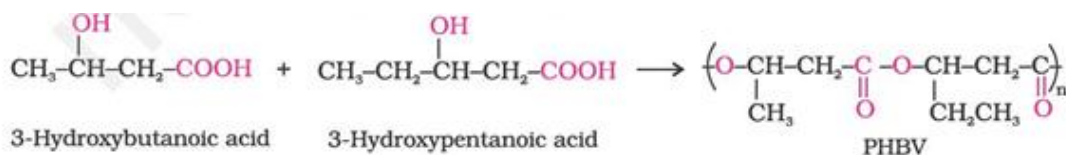

(iii) Neoprene or polychloroprene is formed by the free radical polymerization of chloroprene.

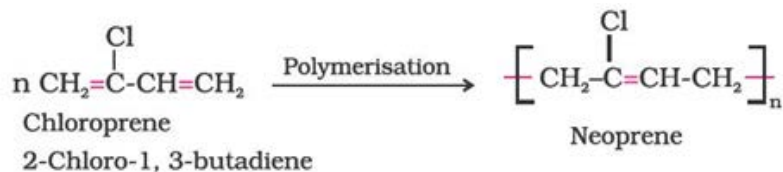

Q15. Predicts the products of the following reactions:

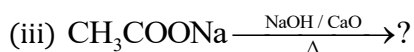
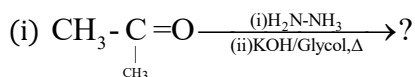

Sol.15

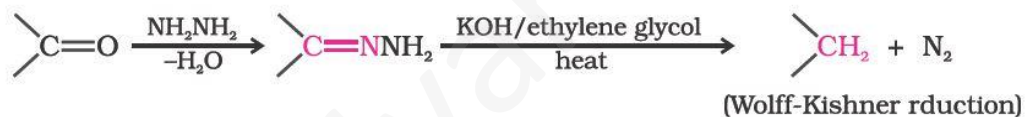

The product is Propane



Q16. How do you convert the following?

(i) Phenol to anisole

(ii) Propan-2-ol to 2-methylpropan-2-ol

(iii) Aniline to phenol

Sol16. (i)

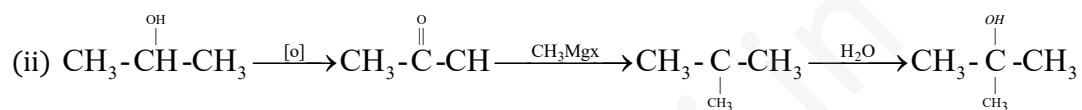
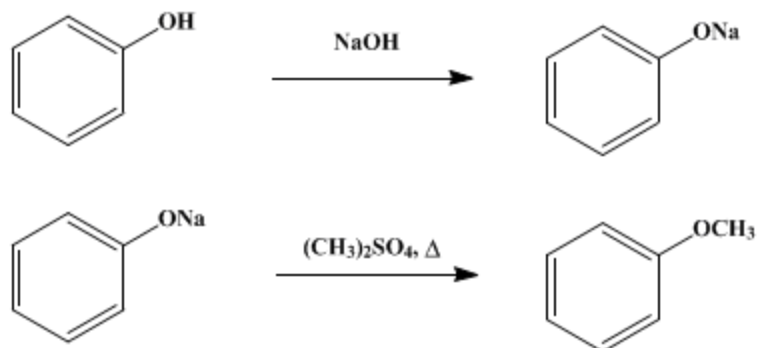

2 Methyl propane 2-ol

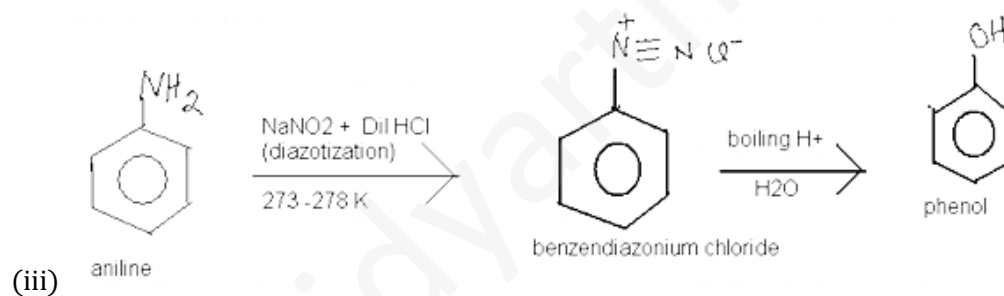

OR

Q16. (a) Write the mechanism of the following reaction:

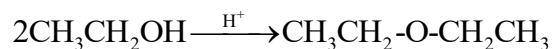

(b) Write the equation involved in the acetylation of salicylic acid.

Sol.16 (a)

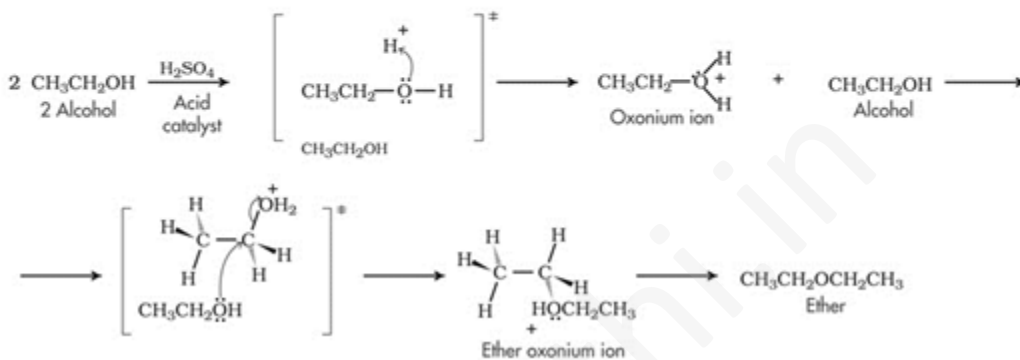
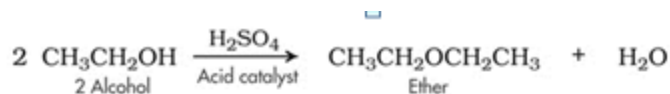

(b)

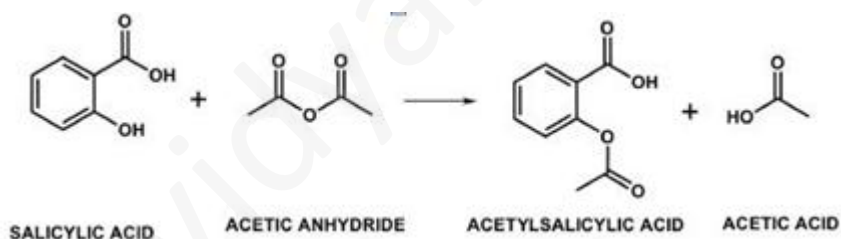

- Q17. (i) Which of the following is a disaccharide: Starch, Maltose, Fructose, Glucose?
- (ii) What is the difference between fibrous protein and globular protein?
- (iii) Write the name of vitamin whose deficiency cause bone deformities in children.

Sol.17 (i) A **disaccharide** is a sugar (a carbohydrate) composed of two monosaccharide's. It is formed when two sugars are joined together and a molecule of water is removed

(ii) Fibrous Proteins (Examples: Silk, Skin, wool etc)

1. They are insoluble in water, acids. Bases etc.

2. They have comparatively stronger intermolecular forces of attraction.

3. They have thread like structure.

4. They have helical or sheet structure.

Global Proteins (Example: Egg albumin, Casein of milk)

1. They are soluble in water, acids. Bases etc.

2. They have comparatively stronger intermolecular forces of attraction.

3. They have thread like structure.

4. They have helical or sheet structure.

(iii) Rickets is a disorder *caused* by a lack of vitamin D,

Q18. Give reasons:

(a) n- Butyl bromide has higher boiling point than t-butyl bromide,

(b) Racemic mixture is optically inactive.

(c) The presence of nitro group (-NO₂) at o/p positions increases the reactivity of haloarenes towards nucleophilic substitution reactions.

Sol.18 (a) n butyl bromide has higher surface area than t-butyl bromide hence higher boiling point.

(b) **racemic mixture (racemate)** consists of an equimolar mixture of both enantiomers and is therefore optically inactive, i.e. one isomer cancels out the rotation of plane polarised light caused by the other isomer

(c) The reactivity of haloarenes is markedly affected by the presence of certain groups at certain positions of the ring. The presence of electron withdrawing groups such as. -NO₂, -CN, -COOH, etc. at 'o' and 'p' positions to the halogen atom, greatly activates the halogen towards nucleophilic substitution reactions. For example, chlorobenzene is converted into phenol by aqueous NaOH only at temperatures above 573 K, whereas 'p' chloronitrobenzene is converted into nitrophenol by aqueous NaOH at a lower temperature of 433K. As the number of ortho and para intro groups on the ring is increased the reactivity increases.

Q19. 3.9 g of benzoic acid dissolved in 49 g of benzene shows a depression in freezing point of 1.62 K. Calculate the van't Hoff factor and predict the nature of solute (associated or dissociated).

(Given Molar mass of benzoic acid = 122 g mol⁻¹, K_f for benzene = 4.9 K kg mol⁻¹)

Sol.19 ΔT_f

$$= i k_f m$$

$$1.62 = i \cdot 4.9 \times \frac{3.9}{4.9 \cdot 0.031}$$

$$\Rightarrow i = 0.522$$

Van't hof factor = 0.522

As $i < 1$

Solute is associated type

- Q20.** (i) Indicate the principle behind the method used for the refining of zinc.
 (ii) What is the role of silicon in the extraction of copper?
 (iii) Which form of the iron is the purest form of commercial iron?

Sol.20 (i) Electrolytic Refining

(ii) During the roasting one, a mixture of FeO and Cu₂O is obtained.



The role of silica in the metallurgy of copper is to remove the iron oxide obtained during the process of roasting. If the sulphide ore of copper iron, then silica (SiO₂) is added as flux before roasting. Then, FeO combines with silica to form iron silicate, FeSiO₃ (slag).

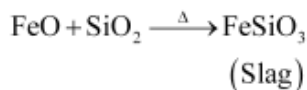

(iii) **Wrought iron** is an iron alloy with a very low carbon (less than 0.08%) content is the purest form of iron.

- Q21.** An element with molar mass 27 g mol⁻¹ forms a cubic unit cell with edge length 4.05 × 10⁻⁸ cm. If its density is 2.7 g cm⁻³, what is the nature of the cubic unit cell?

Sol.21 $d = \text{---}$

$$\Rightarrow z = 2.7 \times (4.05 \times 10^{-8})^3 \times \frac{6.022}{\text{---}}$$

$$\Rightarrow z = \frac{400.04}{2.7}$$

$$= 4.0004$$

$$Z = 4,$$

\Rightarrow fcc crystal lattice

Q22. (a) How would you account for the following:

(i) Actinoid contraction is greater than lanthanoid contraction.

(ii) Transition metals form colored compounds.

(b) Complete the following equation:

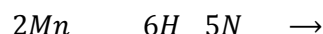

Sol.22 (a) (i) In actinoids, 5f orbitals are filled. These 5f orbitals have a proper shielding effect than 4f orbitals (in lanthanoids). Thus, the effective nuclear charge experienced by electrons in valence shells in case of actinoids is much more than that experienced by lanthanoids. Hence, the size contraction in actinoids is greater as compared to that in lanthanoids.

(ii) Colored compound of transition elements is associated with partially filled (n-1) orbitals. The transition metal ions containing unpaired d-electrons undergo electronic transition from one d-orbital to another. During this d-d transition process the electrons absorb certain energy from the radiation and emit the remainder of energy as colored light. The color of ion is complementary of the color absorbed by it. Hence, colored ion is formed due to d-d transition which falls in visible region for all transition elements.

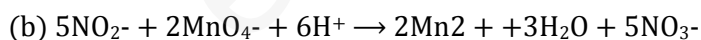

Q23. Mr. Roy, the principal of one reputed school organized a seminar in which he invited parents and principals to discuss the serious issue of diabetes and depression in students. They all resolved this issue by strictly banning the junk food in schools and to introduce healthy snacks and drinks like soup, lassi, milk etc. in school canteens. They also decided to make compulsory half an hour physical activities for the students in the morning assembly daily. After six months, Mr. Roy conducted survey in most of the schools and discovered a tremendous improvement in the health of students.

After reading the above passage, answer the following:

(i) What are the values (at least two) displayed by Mr. Roy?

(ii) As a student, how can you spread awareness about this issue?

(iii) What are tranquilizers? Give an example.

(iv) Why is use of aspartame limited to cold foods and drinks?

Sol.23 (i) **Metabolic Process**, state of low mood and aversion to school activities

(ii) As a student I will educate high school students, teachers, and parents about the illness of depression. Through a student curriculum, a training program for health and school-based professionals, and presentations for parents and communities, student delivers the core message that depression and bipolar disorder are treatable medical illnesses and that concerned individuals should seek help.

Through this work, student aims to increase awareness about mood disorders in young people while stressing the need for evaluation and treatment.

(iii) **Tranquillizers or Hypnotics**

The drugs which act on the central nervous systems (CNS) and help in reducing stress and fatigue by inducing a sense of well being are called tranquillizers.

The most commonly used tranquillizers are barbituric acid and its 5, 5 – disubstituted derivatives such as veronal, luminal, seconal amytal and membutal.

(iv) Aspartame becomes unstable at cooking temperature. This is the reason why its use is limited to cold foods and drinks.

Q24. An aromatic compound 'A' of molecular formula C_7H_7ON undergoes a series of reactions as shown below. Write the structures of A, B, C, D and E in the following reactions:

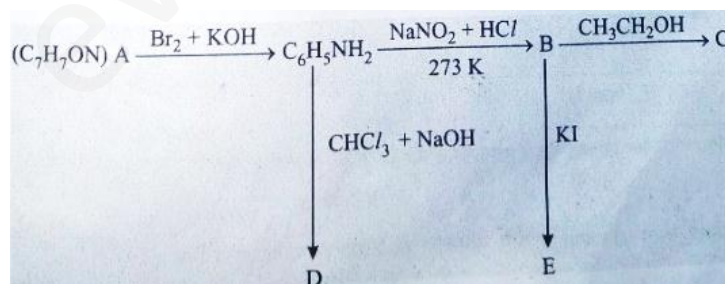

Sol.24 A \rightarrow benzamide or benzenecarboxamide, C_7H_7NO ,

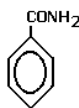

B \rightarrow Diazonium Salt $\rightarrow C_6H_5N_2Cl$

C $\rightarrow C_6H_5OC_2H_5$

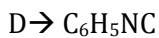
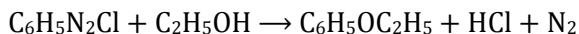

OR

Q24. (a) Write the structures of main products when aniline reacts with the following reagents:

(i) Br_2 water

(ii) HCl

(iii) $(\text{CH}_3\text{CO})_2\text{O}$

(b) Arrange the following in the increasing order of their boiling point:

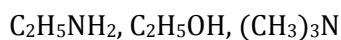

(c) Give a simple chemical test to distinguish between the following pair of compounds:



Sol.24 (a) (i) The reaction with bromine water

If bromine water is added to phenylamine, the bromine water is decolourised and a white precipitate is formed. This is exactly like the reaction which happens with phenol.

The precipitate is 2, 4, 6-tribromophenylamine.



2,4,6-tribromophenylamine

Notice the multiple substitution around the ring – into all the activated positions. (The 6-position is, of course, just the same as the 2-position. Both are next door to the $-\text{NH}_2$ group.)

(ii) Anilinium chloride is an aromatic amounting salt.

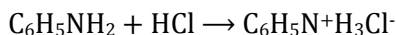

(iii)

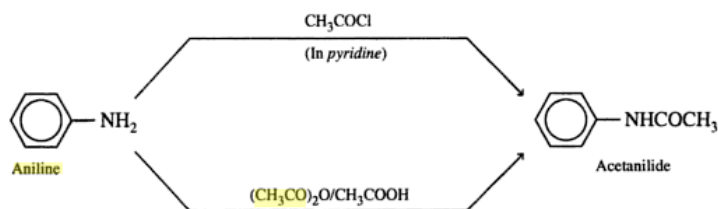

(b) $(\text{CH}_3)_3\text{N} < \text{C}_2\text{H}_5\text{NH}_2 < \text{C}_2\text{H}_5\text{OH}$

(c) Lucas test , Hinsberg test

Q25. For the hydrolysis of methyl acetate in aqueous solution, the following result were obtained:

t/s	0	30	60
$[\text{CH}_3\text{COOCH}_3]/\text{mol L}^{-1}$	0.60	0.30	0.15

(i) Show that it follows pseudo first order reaction, as the concentration of water remains constant.

(ii) Calculate the average rate of reaction between the time interval 30 to 60 seconds.

(Giving $\log 2 = 0.3010$, $\log 4 = 0.6021$)

Sol.25 (i) For pseudo first order reaction, the reaction should be first order with respect to ester when $[\text{H}_2\text{O}]$ is constant. The rate constant k for pseudo first order reaction is $k \frac{2.303}{\log} \frac{a-x}{a}$ where $k' = k[\text{H}_2\text{O}]$

By using this formula and calculating for time intervals we get same $k'[\text{H}_2\text{O}]$. So Pseudo first order.

(ii) Av. rate b/w 30 to 60s

$$= \frac{\partial[\text{Ester}]}{\partial t}$$

$$= \frac{0.30 - 0.15}{30 - 60}$$

$$= \frac{0.15}{-30} = \text{-----}$$

$$= 5 \times 10^{-3} \text{ mol L}^{-1} \text{ S}^{-1}$$

OR

Q25. (a) For a reaction $\text{A} + \text{B} \rightarrow \text{P}$, the rate is given by

$$\text{Rate} = k [A][B]^2$$

- (i) How is the rate of reaction affected if the concentration of B is doubled?
- (ii) What is the overall order of reaction if A is present in large excess?
- (b) A first order reaction takes 30 minutes for 50% completion. Calculate the time required for 90% completion of this reaction.

$$(\log 2 = 0.3010)$$

Sol.25 (a) (i) $R = k [A] [B]^2$, If B is doubled

$$R = 4k [A] [B]^2 \Rightarrow 4 \text{ times.}$$

(ii) If A is in excess, then order will be two orders.

(b) For 1st order, $t_{1/2} = \frac{0.693}{k} \Rightarrow k = \frac{0.693}{t_{1/2}}$

$$t = \frac{2.303}{k} \log \frac{1}{0.1} = \frac{2.303}{0.693} \log \frac{1}{0.1}$$

$$= \frac{2.303}{0.693} = 99.69$$

$$= 100 \text{ minutes}$$

Q26. (a) Account the following:

- (i) Acidic character increases from HF to HI.
- (ii) There is large difference between the melting and boiling points of oxygen and sulphur.
- (iii) Nitrogen does not form penthalide.

(b) Draw the structures of the following:

(i) CF_3

(ii) XeF_4

Sol.26 (a)(i) Acidic strength: In gaseous state, hydrogen halides are covalent. But in aqueous solutions, they ionise and behave as acids. The acid strength of these acids decreases in the order $HI > HBr > HCl > HF$

Thus HF is the weakest acid and HI is the strongest acid among these halogen acids.

Explanation : The above order of acidic strength is reverse of that expected on the basis of electronegativity. Fluorine is the most electronegative halogen, therefore, the electronegativity difference will be maximum in HF and should decrease gradually as

we move towards iodine through chlorine and bromine. Thus, HF should be more ionic in nature and consequently it should be strongest acid. Although many factors contribute towards the relative acidic strengths, the major factor is the bond dissociation energy. The bond dissociation energy decreases from HF to HI so that HF has maximum bond dissociation energy and HI has the lowest value.

Hydrogen halide HF HCl HBr HI

Bond dissociation energy (kJ/mol) 566 431 366 299

-I bond is weakest, it can be easily dissociated into H^+ and I^- - Since H^+ ions while HF can be dissociated with maximum difficulty. Thus HI is the strongest acid while HF is the weakest acid among the hydrogen halides.

(ii) Oxygen gas exists as O_2 molecules while sulfur exists as S_8 rings. Since the electron clouds around sulphur extend out farther from the sulphur nucleus than the electron cloud around oxygen, they can have a greater effect through London Dispersion forces. The electron cloud of oxygen is less polarizable (squishy) than that of sulphur because the electrons are more tightly held by the oxygen nucleus so the forces between molecules is less for oxygen, O_2 , than those associated with the S_8 molecule.

So, you have a much larger molecular mass for sulphur which will have some effect on the boiling point, and London Dispersion forces for S_8 are much stronger for sulphur. This combination makes the boiling and melting points of sulphur, S_8 , significantly higher than those of oxygen, O_2 .

_____	O_2	_____	S_8
melting point....	-219 Celsius.....	115 Celsius	
boiling point....	-183 Celsius.....	445 Celsius	

This same trend continues with selenium and tellurium which are also in the oxygen family of elements. The trend is expected because these properties follow the trend "boiling and melting points increase for a family of elements down the periodic table."

(iii) Nitrogen is a 2nd period element and its a chemical sin to put more than 8 valence electrons around nitrogen as there are only four orbitals (s.p.p.p) available in the 2nd energy level.

Excitation to 3 level is "impossible". The inner core of 1s cannot be disturbed. Pentahalides would essentially put 10 electrons around N and hence NOT POSSIBLE.

Oxidation number on the other hand is a number that has no significance to structures. Its designated by noting the charge on the atom after theoretically giving the bonded electrons in a bond to the more electronegative element.

In NO_3^- - we have nitrogen forming 4 covalent bonds but the oxidation state is +5.

Oxidation number or state is a mere number and nothing more.

(b) (i)

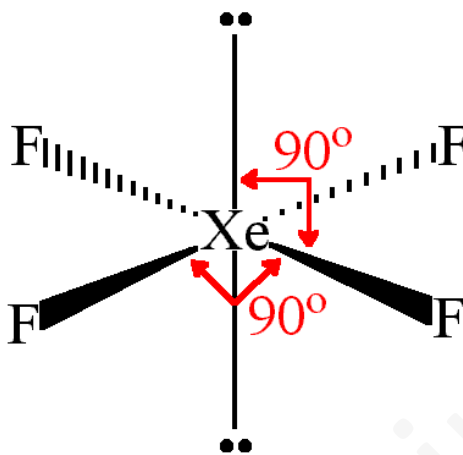

(ii)

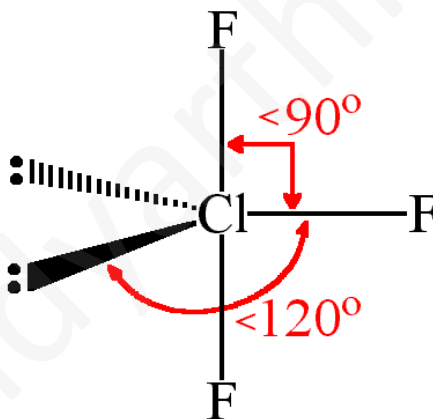

OR

- Q26. (i) Which allotrope of phosphorous is more reactive and why?
- (ii) How the supersonic jet aeroplanes are responsible for the depletion of ozone layers?
- (iii) F_2 has lower bond dissociation enthalpy than Cl_2 . Why?
- (iv) Which noble gas is used in filling balloons for meteorological observations?
- (v) Complete the equation:

$$XeF_2 + PF_5 \rightarrow$$

Sol.26 All of the allotropes of phosphorus are too reactive to be found uncombined in nature. White phosphorus is the most reactive of the allotropes, reacting spontaneously with oxygen in the air (it is commonly stored in water). Its name comes from the Greek for 'light bearer' due to the faint glow it emits on exposure to oxygen. (The word 'phosphorescence' is derived from this phenomenon, though this reaction of phosphorus with oxygen is more correctly called 'chemiluminescence'.) It's surprising that an element as reactive as phosphorus was discovered as early as 1669, when it was isolated from urine. Elemental phosphorus is used in safety matches and flares.

White phosphorus consists of P_4 molecules. The four phosphorus atoms are located at the vertices of a tetrahedron, as shown in the structure above. Given the symmetry of tetrahedral all four phosphorus atoms are in equivalent positions in the P_4 molecule. The bond angles are therefore 60° . One would expect a bond angle of 107° , as in ammonia, so there is considerable bond strain in the molecule. This is an important factor in the great reactivity of white phosphorus. The red and black allotropes of phosphorus are less strained and so less unstable.

2. Nitrogen oxide emitted by large number of Jet Aircrafts, Supersonic transport aeroplanes may cause destruction in the ozone layer resulting disastrous effects on flora and fauna.

3. F_2 is a smaller molecule than Cl_2 . This means that the bonded electrons in F_2 are closer to the outer shell unbonded electrons. Due to the electron repulsion theory, the bonded electrons repel the outer shell unbonded electrons far more in F_2 than they would in Cl_2 since Cl_2 has more shells so more shielding of the outer electrons. The fact that the bonded electrons in F_2 repel the unbonded electrons so much makes the molecule weak, so it is easier to break.

4. Helium

5. $XeF_2 + PF_5 \rightarrow [XeF]^+ + [PF_6]^-$