

PRACTICE BOARD EXAMINATION

Class 12th Physics (Electrostatics and Current)

Time allowed: 3 hours

Maximum marks: 70

General Instructions:

- (i) Question numbers 1 to 8 are very short answer type questions, carrying **one** mark each.
- (ii) Question numbers 9 to 16 are short answer type questions, carrying **two** marks each.
- (iii) Question numbers 17 to 25 are also short answer questions, carrying **three** marks each.
- (iv) Question number 26 is a **value based question**, carrying **four** marks.
- (v) Question numbers 27 to 29 are long answer type questions, carrying **five** marks each.

Q.1> In a hydrogen atom, an electron revolves around a proton. Which of these two exerts a greater electrostatic force on the other?

Q.2> What is the force experienced by a positively charged particle Q moving at right angles to a uniform electric field E.

Q.3> What is the order of voltages that can be built up using a Van De Graff generator?

Q.4> What is the angle b/w Electric field and Dipole moment at an axial point?

Q.5> Define gyromagnetic ratio. What is its value?

Q.6> State the condition in which terminal voltage across a secondary cell is equal to its emf.

Q.7> The dielectric strength of air is 3×10^6 V/m. What is the maximum charge that can be safely stored on a sphere of radius 10m?

Q.8> Name two types of commercially available resistors.

Q.9> On the same graph plot the variation of E versus R and V versus R for a point charge.

Q.10> Define mobility and mention its SI unit

Q.11> Two resistors are connected in parallel b/w A and B to give a net resistance of 2 ohms. When one of these resistors is broken, the net resistance becomes a 3 ohms. What is the resistance of the resistor that was broken?

Q.12> Using a suitable graph, explain why nichrome is used in standard resistance coils.

Q.13> A velocity selector is to be designed for particles of velocity 10m/s. What magnetic field should be employed if the electric field in it is 100 N/C

Q.14> An alpha particle and a proton accelerated by the same potential difference enter into a magnetic field. Find the ratio of their radius and the ratio of their frequency.

Q.15> Explain why a potentiometer is preferred over a voltmeter for measuring potential differences.

Q.16> In a meter bridge experiment with a fixed resistor of 10 ohm, the balance length is found to be 75cm. What resistance should be added in series with this fixed resistor so as to bring the null point in the center of the wire.

Q.17> The resistivity of a metal X is 3.2×10^{-8} while the free electron density is $5 \times 10^{28} \text{ m}^{-3}$. Find the drift velocity of electrons if a potential gradient of 1 Vm^{-1} is applied across X.

Q.18> What type of materials are used for making

- (a) Permanent magnets
- (b) Transformer cores.

Give two line reasons for each

Q.19> In the circuit diagram, what is the reading of the voltmeter?
 (b) What resistance should be connected in series with the $R = 6 \text{ ohm}$ resistor so that the voltmeter reading become zero?

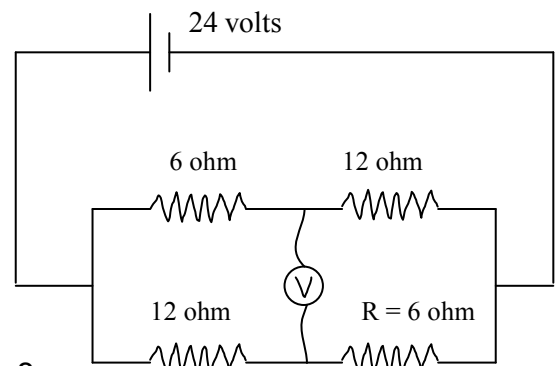

Q.20> Cell A has an emf E_A and internal resistance r_A while cell B has emf E_B and internal resistance r_B . Derive an expression for the equivalent emf and internal resistance

Q.21> A long cylinder of radius R_0 is carrying a current I_0 , which is uniformly distributed over its cross section. Derive an expression for the magnitude of magnetic field inside as well as outside the wire. Plot a curve to show the variation of magnetic field with radial distance.

Q.22> Three charges Q , Q and $-Q$ are placed on the vertices of an equilateral triangle of side L . Find the net force experienced by the charge Q and the net force experienced by the charge $-Q$.

Q.23> Derive an expression for the torque acting on a current carrying loop placed in a uniform magnetic field. Hence define the magnetic moment of a current carrying loop.

Q.24> Use kirchoff's laws to deduce the condition of a balanced wheatstone bridge.

Q.25> Explain mathematically, why the resistance of metals increases while that of semiconductor decreases with the rise in temperature. Plot Resistance versus Temperature for Cu and for Silicon.

Q.26> During a thunderstorm, Vishal advices his friends to remain inside the car as this is safer. Explain why this is true. (b) What are the values shown by Vishal?

Q.27> Conductors A and B are two concentric hollow metallic shells of radius R_A and R_B . A is given a charge Q_A while B is given a charge Q_B . Find the electric potential and field at a distance R from the center such that

- (a) $R < R_A$
- (b) $R_A < R < R_B$

(c) $R > R_B$

Q.28> Using a labeled diagram explain the construction and working of a moving coil galvanometer. Define its current and voltage sensitivity and explain how they can be increased.

(b) A galvanometer with a coil resistance of 5 ohm can tolerate a maximum current of 10mA. Explain how this can be converted into an ammeter of range 1A.

Q.29> There are a total of N cells each of emf E and internal resistance r . They are connected in the form of a 2 dimensional array of “ n ” rows each having equal number of cells. What is the maximum current that can be obtained from this combination.

(b) This array is connected to an external resistor R . Derive an expression for the current flowing through R . For what value of R is this current maximum.