

IIT – JEE - 2009

(PAPER – 1, CODE – 1)

Time: 3 Hours

Maximum Marks: 240

A. Question paper format:

1. The question paper consists of 3 parts (Chemistry, Mathematics and Physics). Each part has 4 sections.
2. **Section I** contains 8 multiple choice questions. Each question has 4 choices (A), (B), (C) and (D) for its answer, out of which **only one is correct**.
3. **Section II** contains 4 multiple choice questions. Each question has 4 choices (A), (B), (C) and (D) for its answer, out of which **one or more is/are correct**.
4. **Section III** contains 2 groups of questions. Each group has 3 questions based on a paragraph. Each question has 4 choices (A), (B), (C) and (D) for its answer, out of which **only one is correct**.
5. **Section IV** contains 2 questions. Each question has four statements (A, B, C and D) given in column I and five statements (p, q, r, s and t) in Column II. Any given statement in column I can have correct matching with **one or more** statements(s) given in column II. For example, if for a given question, statement B matches with the statements given in q and r, then for that particular question, against statement B, darken the bubbles corresponding to q and r in the ORS.

B. Marking scheme:

6. For each question in **Section I** you will be **awarded 3 marks** if you darken the bubble corresponding to the correct answer and **zero mark** if no bubble is darkened. In case of bubbling of incorrect answer, **minus one (-1) mark** will be awarded.
7. For each question in **Section II**, you will be **awarded 4 marks** if you darken the bubble(s) corresponding to the correct choice(s) for the answer, and **zero mark** if no bubble is darkened. In all other cases, **Minus one (-1) mark** will be awarded.
8. For each question in **Section III**, you will be **awarded 4 marks** if you darken the bubble(s) corresponding to the correct answer and **zero mark** if no bubble is darkened. In all other cases, **minus one (-1) mark** will be awarded.
9. For each question in **Section IV**, you will be **awarded 2 marks for each row** in which you have darkened the bubble(s) corresponding to the correct answer. Thus, each question in this section carries a maximum of 8 marks. There is **no negative marking** for incorrect answer(s) for this section.

IITJEE 2009 (PAPER-1, CODE-1)

PART I: CHEMISTRY

SECTION-I Single Correct Choice Type

This section contains 8 multiple choice questions. Each question has 4 choices (A), (B), (C) and (D) for its answer, out of which ONLY ONE is correct.

1. The Henry's law constant for the solubility of N_2 gas in water at 298 K is 1.0×10^5 atm. The mole fraction of N_2 in air is 0.8. The number of moles of N_2 from air dissolved in 10 moles of water at 298 K and 5 atm pressure is
- (A) 4.0×10^{-4} (B) 4.0×10^{-5}
(C) 5.0×10^{-4} (D) 4.0×10^{-6}

Sol. (A)

$$P = K_H \chi_{N_2}$$

$$0.8 \times 5 = 1 \times 10^5 \times \chi_{N_2}$$

$$\chi_{N_2} = 4 \times 10^{-5} \quad (\text{in 10 moles of water})$$

$$\Rightarrow 4 \times 10^{-5} = \frac{n_{N_2}}{n_{N_2} + 10}$$

$$n_{N_2} \times 5 \times 10^{-5} + 4 \times 10^{-4} = n_{N_2}$$

$$\Rightarrow n_{N_2} = 4 \times 10^{-4}$$

2. The correct acidity order of the following is

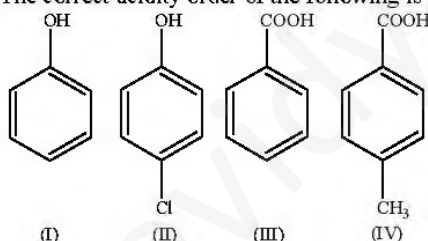

- (A) (III) > (IV) > (II) > (I)
(C) (III) > (II) > (I) > (IV)

- (B) (IV) > (III) > (I) > (II)
(D) (II) > (III) > (IV) > (I)

Sol. (A)

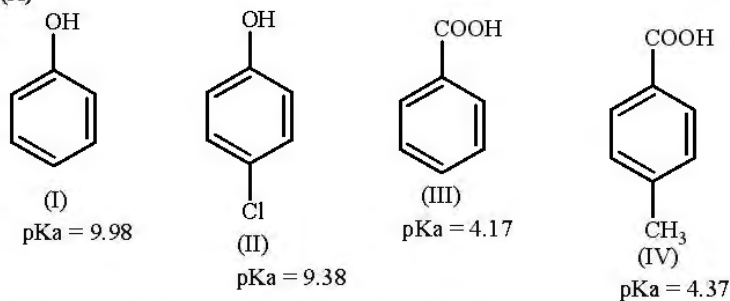

Decreasing order of acidic strength: III > IV > II > I

3. The reaction of P_4 with X leads selectively to P_4O_6 . The X is
 (A) Dry O_2 (B) A mixture of O_2 and N_2
 (C) Moist O_2 (D) O_2 in the presence of aqueous NaOH

Sol. (B)
 $P_4 + 3O_2 \xrightarrow{N_2} P_4O_6$ (exclusively)
 (N_2 is used to retard the further oxidation.)

4. Among cellulose, poly(vinyl chloride), nylon and natural rubber, the polymer in which the intermolecular force of attraction is weakest is
 (A) Nylon (B) Poly(vinyl chloride)
 (C) Cellulose (D) Natural Rubber

Sol. (D)
 As chain of natural rubber involves weak van der Waal force of interaction.

5. Given that the abundances of isotopes ^{54}Fe , ^{56}Fe and ^{57}Fe are 5%, 90% and 5% respectively, the atomic mass of Fe is
 (A) 55.85 (B) 55.95
 (C) 55.75 (D) 56.05

Sol. (B)

$$\bar{A} = \frac{\sum A_i x_i}{\sum x_i}$$

$$\bar{A} = 54 \times 0.05 + 56 \times 0.90 + 57 \times 0.05 \quad (\text{where } \bar{A} \text{ is atomic mass of Fe})$$

$$\bar{A} = 55.95$$

6. The IUPAC name of the following compound is

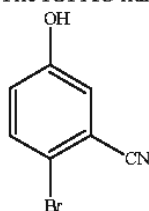

- (A) 4-Bromo-3-cyanophenol (B) 2-Bromo-5-hydroxybenzonitrile
 (C) 2-Cyano-4-hydroxybromobenzene (D) 6-Bromo-3-hydroxybenzonitrile

Sol. (B)
 Priority of CN is highest.

7. Among the electrolytes Na_2SO_4 , $CaCl_2$, $Al_2(SO_4)_3$ and NH_4Cl , the most effective coagulating agent for Sb_2S_3 sol is
 (A) Na_2SO_4 (B) $CaCl_2$
 (C) $Al_2(SO_4)_3$ (D) NH_4Cl

Sol. (C)
 As Sb_2S_3 is a negative sol, so, $Al_2(SO_4)_3$ will be the most effective coagulant due to higher charge density on Al^{3+} in accordance with Hardy-Schulze rule.
 Order of effectiveness of cations: $Al^{3+} > Ca^{++} > Na^+ > NH_4^+$

8. The term that corrects for the attractive forces present in a real gas in the van der Waals equation is

- (A) nb (B) $\frac{an^2}{V^2}$
(C) $-\frac{an^2}{V^2}$ (D) $-nb$

Sol. (B)

The measure of force of attraction for 'n' moles of real gas $\left(\frac{n^2a}{V^2}\right)$

$$\left(P + \frac{n^2a}{V^2}\right)(V - nb) = nRT$$

SECTION-II
Multiple Correct Choice Type

This section contains 4 multiple choice questions. Each question has 4 choices (A), (B), (C) and (D) for its answer, out which **ONE OR MORE** is/are correct.

9. The compound(s) formed upon combustion of sodium metal in excess air is(are)

- (A) Na_2O_2 (B) Na_2O
(C) NaO_2 (D) $NaOH$

Sol. (A, B) in dry air

10. The correct statement(s) about the compound $H_3C(HO)HC-CH=CH-CH(OH)CH_3$, (X) is(are)

- (A) The total number of stereoisomers possible for X is 6
(B) The total number of diastereomers possible for X is 3
(C) If the stereochemistry about the double bond in X is *trans*, the number of enantiomers possible for X is 4
(D) If the stereochemistry about the double bond in X is *cis*, the number of enantiomers possible for X is 2

Sol. (A, D)

11. The compound(s) that exhibit(s) geometrical isomerism is(are)

- (A) $[Pt(en)Cl_2]$ (B) $[Pt(en)_2]Cl_2$
(C) $[Pt(en)_2Cl_2]Cl_2$ (D) $[Pt(NH_3)_2Cl_2]$

Sol. (C, D)

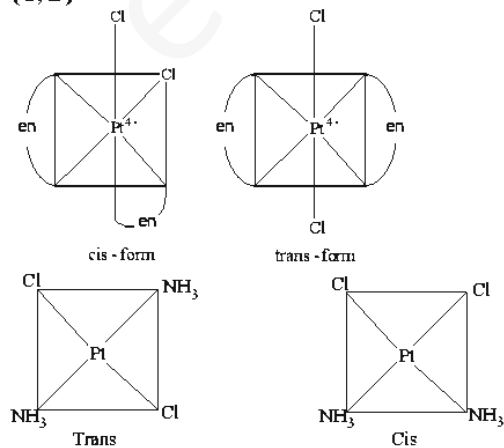

12. The correct statement(s) regarding defects in solids is(are)
- (A) Frenkel defect is usually favoured by a very small difference in the sizes of cation and anion
 (B) Frenkel defect is a dislocation defect
 (C) Trapping of an electron in the lattice leads to the formation of F-center
 (D) Schottky defects have no effect on the physical properties of solids

Sol. (B, C)

SECTION-III
Comprehension Type

This section contains 2 groups of questions. Each group has 3 multiple choice question based on a paragraph. Each question has 4 choices (A), (B), (C) and (D) for its answer, out of which **ONLY ONE** is correct.

Paragraph for Question Nos. 13 to 15

A carbonyl compound P, which gives positive iodoform test, undergoes reaction with MeMgBr followed by dehydration to give an olefin Q. Ozonolysis of Q leads to a dicarbonyl compound R, which undergoes intramolecular aldol reaction to give predominantly S.

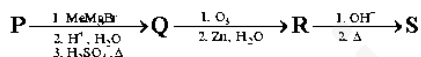

13. The structure of the carbonyl compound P is

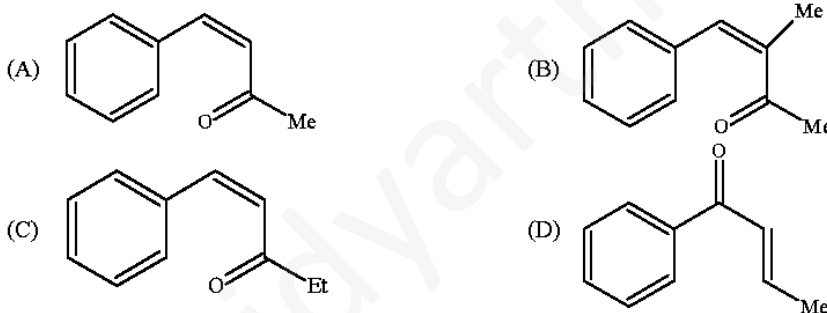

Sol. (B)

14. The structure of the products Q and R, respectively, are

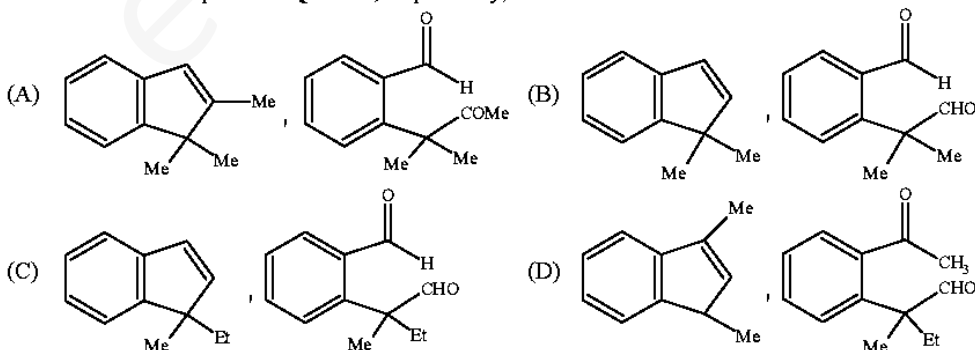

Sol. (A)

15. The structure of the product S is

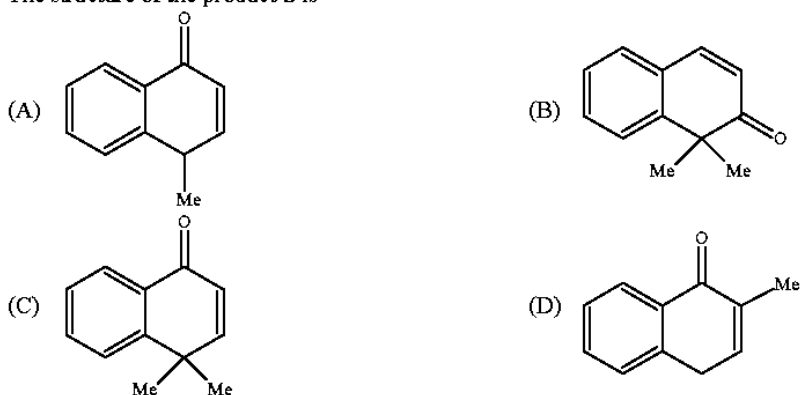

Sol. (B)

Solution for the question nos. 13 to 15

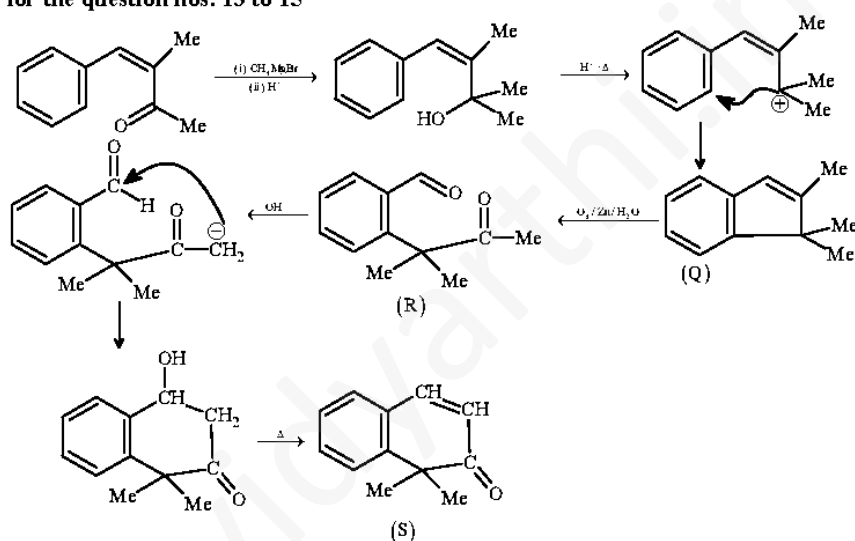

Paragraph for Question Nos. 16 to 18

p-Amino-*N,N*-dimethylaniline is added to a strongly acidic solution of X. The resulting solution is treated with a few drops of aqueous solution of Y to yield blue coloration due to the formation of methylene blue. Treatment of the aqueous solution of Y with the reagent potassium hexacyanoferrate (II) leads to the formation of an intense blue precipitate. The precipitate dissolves on excess addition of the reagent. Similarly, treatment of the solution of Y with the solution of potassium hexacyanoferrate (III) leads to a brown coloration due to the formation of Z.

16. The compound X is

(A) NaNO_3

(C) Na_2SO_4

(B) NaCl

(D) Na_2S

Sol. (D)

17. The compound Y is

(A) MgCl_2

(C) FeCl_3

(B) FeCl_2

(D) ZnCl_2

Sol. (C)

18. The compound Z is
 (A) $Mg_3[Fe(CN)_6]$ (B) $Fe[Fe(CN)_6]$
 (C) $Fe_4[Fe(CN)_6]_3$ (D) $K_2Zn_3[Fe(CN)_6]_2$

Sol. (B)

Solution for the question nos. 16 to 18

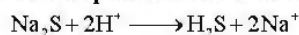

(X)

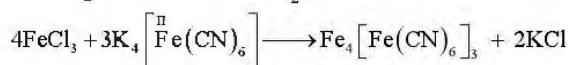
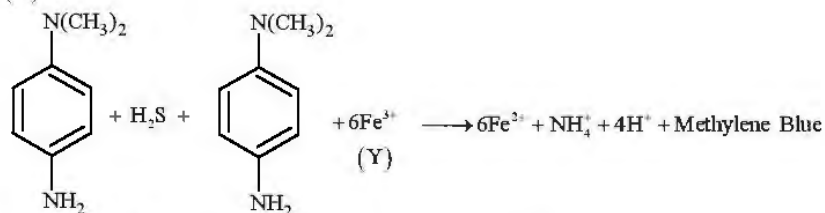

Intense blue



Brown coloration

(X) – Na_2S

(Y) – $FeCl_3$

(Z) – $Fe[Fe(CN)_6]$

SECTION – IV

Matrix – Match Type

This section contains 2 questions. Each question contains statements given in two columns, which have to be matched. The statements in **Column I** are labelled A, B, C and D, while the statements in **Column II** are labelled p, q, r, s and t. Any given statement in **Column I** can have correct matching with **ONE OR MORE** statement(s) in **Column II**. The appropriate bubbles corresponding to the answers to these questions have to be darkened as illustrated in the following example:

If the correct matches are A – p, s and t; B – q and r; C – p and q; and D – s and t, then the correct darkening of bubbles will look like the following:

	p	q	r	s	t
A	<input checked="" type="radio"/>	<input checked="" type="radio"/>	<input checked="" type="radio"/>	<input checked="" type="radio"/>	<input checked="" type="radio"/>
B	<input checked="" type="radio"/>	<input checked="" type="radio"/>	<input checked="" type="radio"/>	<input type="radio"/>	<input type="radio"/>
C	<input checked="" type="radio"/>	<input checked="" type="radio"/>	<input type="radio"/>	<input type="radio"/>	<input type="radio"/>
D	<input type="radio"/>	<input type="radio"/>	<input type="radio"/>	<input checked="" type="radio"/>	<input checked="" type="radio"/>

19. Match each of the compounds in **Column I** with its characteristic reaction(s) in **Column II**.

Column – I	Column – II
(A) $CH_3CH_2CH_2CN$ (B) $CH_3CH_2OCOCH_3$ (C) $CH_3-CH=CH-CH_2OH$ (D) $CH_3CH_2CH_2CH_2NH_2$	(p) Reduction with $Pd-C/H_2$ (q) Reduction with $SnCl_2/HCl$ (r) Development of foul smell on treatment with chloroform and alcoholic KOH (s) Reduction with diisobutylaluminium hydride (DIBAL-H) (t) Alkaline hydrolysis

Sol. ((A – p, q, s, t) (B – s, t) (C – p) (D – r))

20. Match each of the diatomic molecules in **Column I** with its property/properties in **Column II**.

Column – I	Column – II
(A) B ₂	(p) Paramagnetic
(B) N ₂	(q) Undergoes oxidation
(C) O ₂ ⁻	(r) Undergoes reduction
(D) O ₂	(s) Bond order ≥ 2
	(t) Mixing of 's' and 'p' orbitals

Sol. ((A – p, r, t) (B – s, t) (C – p, q) (D – p, q, s)) [According to MOT]

PART II: MATHEMATICS

SECTION-I Single Correct Choice Type

This section contains 8 multiple choice questions. Each question has 4 choices (A), (B), (C) and (D) for its answer, out of which **ONLY ONE** is correct.

21. Let $z = x + iy$ be a complex number where x and y are integers. Then the area of the rectangle whose vertices are the roots of the equation $\bar{z}z^3 + z\bar{z}^3 = 350$ is
 (A) 48 (B) 32
 (C) 40 (D) 80

Sol. (A)
 $\bar{z}z(\bar{z}^2 + z^2) = 350$
 Put $z = x + iy$
 $(x^2 + y^2)(x^2 - y^2) = 175$
 $(x^2 + y^2)(x^2 - y^2) = 5 \cdot 5 \cdot 7$
 $x^2 + y^2 = 25$
 $x^2 - y^2 = 7$
 $x = \pm 4, y = \pm 3$
 $x, y \in I$
 Area = $8 \times 6 = 48$ sq. unit.

22. If \vec{a} , \vec{b} , \vec{c} and \vec{d} are unit vectors such that $(\vec{a} \times \vec{b}) \cdot (\vec{c} \times \vec{d}) = 1$ and $\vec{a} \cdot \vec{c} = \frac{1}{2}$, then
 (A) \vec{a} , \vec{b} , \vec{c} are non-coplanar (B) \vec{b} , \vec{c} , \vec{d} are non-coplanar
 (C) \vec{b} , \vec{d} are non-parallel (D) \vec{a} , \vec{d} are parallel and \vec{b} , \vec{c} are parallel

Sol. (C)
 $(\vec{a} \times \vec{b}) \cdot (\vec{c} \times \vec{d}) = 1$ possible only when $|\vec{a} \times \vec{b}| = |\vec{c} \times \vec{d}| = 1$
 and $(\vec{a} \times \vec{b}) \parallel (\vec{c} \times \vec{d})$
 Since $\vec{a} \cdot \vec{c} = 1/2$ and $\vec{b} \parallel \vec{d}$, then $|\vec{c} \times \vec{d}| \neq 1$.

23. The line passing through the extremity A of the major axis and extremity B of the minor axis of the ellipse $x^2 + 9y^2 = 9$ meets its auxiliary circle at the point M. Then the area of the triangle with vertices at A, M and the origin O is

- (A) $\frac{31}{10}$ (B) $\frac{29}{10}$
(C) $\frac{21}{10}$ (D) $\frac{27}{10}$

Sol. (D)

Equation of line AM is $x + 3y - 3 = 0$

Perpendicular distance of line from origin = $\frac{3}{\sqrt{10}}$

Length of AM = $2\sqrt{9 - \frac{9}{10}} = 2 \times \frac{9}{\sqrt{10}}$

\Rightarrow Area = $\frac{1}{2} \times 2 \times \frac{9}{\sqrt{10}} \times \frac{3}{\sqrt{10}} = \frac{27}{10}$ sq. units.

24. Let $z = \cos\theta + i \sin\theta$. Then the value of $\sum_{m=1}^{15} \text{Im}(z^{2m-1})$ at $\theta = 2^\circ$ is

- (A) $\frac{1}{\sin 2^\circ}$ (B) $\frac{1}{3 \sin 2^\circ}$
(C) $\frac{1}{2 \sin 2^\circ}$ (D) $\frac{1}{4 \sin 2^\circ}$

Sol. (D)

$X = \sin\theta + \sin 3\theta + \dots + \sin 29\theta$

$2(\sin\theta)X = 1 - \cos 2\theta + \cos 2\theta - \cos 4\theta + \dots + \cos 28\theta - \cos 30\theta$

$X = \frac{1 - \cos 30\theta}{2 \sin \theta} = \frac{1}{4 \sin 2^\circ}$

25. Let P(3, 2, 6) be a point in space and Q be a point on the line $\vec{r} = (\hat{i} - \hat{j} + 2\hat{k}) + \mu(-3\hat{i} + \hat{j} + 5\hat{k})$. Then the value of μ for which the vector \overline{PQ} is parallel to the plane $x - 4y + 3z = 1$ is

- (A) $\frac{1}{4}$ (B) $-\frac{1}{4}$
(C) $\frac{1}{8}$ (D) $-\frac{1}{8}$

Sol. (A)

Any point on the line can be taken as

$Q \equiv \{(1-3\mu), (\mu-1), (5\mu+2)\}$

$\overline{PQ} = \{-3\mu-2, \mu-3, 5\mu-4\}$

Now, $1(-3\mu-2) - 4(\mu-3) + 3(5\mu-4) = 0$

$\Rightarrow -3\mu - 2 - 4\mu + 12 + 15\mu - 12 = 0$

$8\mu = 2 \Rightarrow \mu = 1/4$.

26. The number of seven digit integers, with sum of the digits equal to 10 and formed by using the digits 1, 2 and 3 only, is

- (A) 55 (B) 66
(C) 77 (D) 88

Sol. (C)

Coefficient of x^{10} in $(x + x^2 + x^3)^7$

coefficient of x^3 in $(1 + x + x^2)^7$
 coefficient of x^3 in $(1 - x^3)^7 (1 - x)^{-7}$
 $= {}^{7+3-1}C_3 - 7$
 $= {}^9C_3 - 7$
 $= \frac{9 \times 8 \times 7}{6} - 7 = 77.$

Alternate:
 The digits are 1, 1, 1, 1, 1, 2, 3
 or 1, 1, 1, 1, 2, 2, 2
 Hence number of seven digit numbers formed
 $= \frac{7!}{5!} + \frac{7!}{4! 3!} = 77.$

27. Let f be a non-negative function defined on the interval $[0, 1]$. If $\int_0^x \sqrt{1 - (f'(t))^2} dt = \int_0^x f(t) dt$, $0 \leq x \leq 1$, and $f(0) = 0$, then
- (A) $f\left(\frac{1}{2}\right) < \frac{1}{2}$ and $f\left(\frac{1}{3}\right) > \frac{1}{3}$ (B) $f\left(\frac{1}{2}\right) > \frac{1}{2}$ and $f\left(\frac{1}{3}\right) > \frac{1}{3}$
 (C) $f\left(\frac{1}{2}\right) < \frac{1}{2}$ and $f\left(\frac{1}{3}\right) < \frac{1}{3}$ (D) $f\left(\frac{1}{2}\right) > \frac{1}{2}$ and $f\left(\frac{1}{3}\right) < \frac{1}{3}$

Sol. (C)
 $f' = \pm \sqrt{1 - f^2}$
 $\Rightarrow f(x) = \sin x$ or $f(x) = -\sin x$ (not possible)
 $\Rightarrow f(x) = \sin x$
 Also, $x > \sin x \forall x > 0$.

28. Tangents drawn from the point $P(1, 8)$ to the circle $x^2 + y^2 - 6x - 4y - 11 = 0$ touch the circle at the points A and B . The equation of the circumcircle of the triangle PAB is
- (A) $x^2 + y^2 + 4x - 6y + 19 = 0$ (B) $x^2 + y^2 - 4x - 10y + 19 = 0$
 (C) $x^2 + y^2 - 2x + 6y - 29 = 0$ (D) $x^2 + y^2 - 6x - 4y + 19 = 0$

Sol. (B)
 The centre of the circle is $C(3, 2)$.
 Since CA and CB are perpendicular to PA and PB , CP is the diameter of the circumcircle of triangle PAB .
 Its equation is
 $(x - 3)(x - 1) + (y - 2)(y - 8) = 0$
 or $x^2 + y^2 - 4x - 10y + 19 = 0$.

SECTION-II
Multiple Correct Choice Type

This section contains 4 multiple choice questions. Each question has 4 choices (A), (B), (C) and (D) for its answer, out of which **ONE OR MORE** is/are correct

29. In a triangle ABC with fixed base BC , the vertex A moves such that $\cos B + \cos C = 4 \sin^2 \frac{A}{2}$. If a , b and c denote the lengths of the sides of the triangle opposite to the angles A , B and C , respectively, then
- (A) $b + c = 4a$ (B) $b + c = 2a$
 (C) locus of point A is an ellipse (D) locus of point A is a pair of straight lines

Sol. (B, C)

$$2 \cos\left(\frac{B+C}{2}\right) \cos\left(\frac{B-C}{2}\right) = 4 \sin^2 \frac{A}{2}$$

$$\cos\left(\frac{B-C}{2}\right) = 2 \sin\left(\frac{A}{2}\right)$$

$$\Rightarrow \frac{\cos\left(\frac{B-C}{2}\right)}{\sin A/2} = 2$$

$$\Rightarrow \frac{\sin B + \sin C}{\sin A} = 2$$

$$\Rightarrow b + c = 2a \text{ (constant).}$$

30. If $\frac{\sin^4 x}{2} + \frac{\cos^4 x}{3} = \frac{1}{5}$, then

(A) $\tan^2 x = \frac{2}{3}$

(C) $\tan^2 x = \frac{1}{3}$

(B) $\frac{\sin^8 x}{8} + \frac{\cos^8 x}{27} = \frac{1}{125}$

(D) $\frac{\sin^8 x}{8} + \frac{\cos^8 x}{27} = \frac{2}{125}$

Sol. (A, B)

$$\frac{\sin^4 x}{2} + \frac{\cos^4 x}{3} = \frac{1}{5}$$

$$3 \sin^4 x + 2(1 - \sin^2 x)^2 = \frac{6}{5}$$

$$\Rightarrow 25 \sin^4 x - 20 \sin^2 x + 4 = 0$$

$$\Rightarrow \sin^2 x = \frac{2}{5} \text{ and } \cos^2 x = \frac{3}{5}$$

$$\therefore \tan^2 x = \frac{2}{3} \text{ and } \frac{\sin^8 x}{8} + \frac{\cos^8 x}{27} = \frac{1}{125}$$

31. Let $L = \lim_{x \rightarrow 0} \frac{a - \sqrt{a^2 - x^2} - \frac{x^2}{4}}{x^4}$, $a > 0$. If L is finite, then

(A) $a = 2$

(B) $a = 1$

(C) $L = \frac{1}{64}$

(D) $L = \frac{1}{32}$

Sol. (A, C)

$$L = \lim_{x \rightarrow 0} \frac{a - \sqrt{a^2 - x^2} - \frac{x^2}{4}}{x^4} = \lim_{x \rightarrow 0} \frac{1}{x^2(a + \sqrt{a^2 - x^2})} - \frac{1}{4x^2}$$

$$= \lim_{x \rightarrow 0} \frac{(4-a) - \sqrt{a^2 - x^2}}{4x^2(a + \sqrt{a^2 - x^2})}$$

numerator $\rightarrow 0$ if $a = 2$ and then $L = \frac{1}{64}$.

32. Area of the region bounded by the curve $y = e^x$ and lines $x = 0$ and $y = e$ is

(A) $e - 1$

(B) $\int_1^e \ln(e+1-y) dy$

(C) $e - \int_0^1 e^x dx$

(D) $\int_1^e \ln y dy$

Sol. (B, C, D)

$$\begin{aligned} \text{Required Area} &= \int_1^e \ln y dy \\ &= (y \ln y - y)_1^e = (e - e) - \{-1\} = 1. \end{aligned}$$

$$\text{Also, } \int_1^e \ln y dy = \int_1^e \ln(e+1-y) dy$$

$$\text{Further the required area} = e \times 1 - \int_0^1 e^x dx.$$

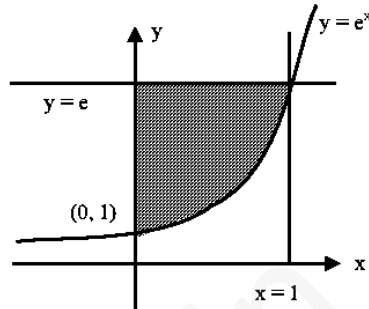

SECTION-III

Comprehension Type

This section contains 2 groups of questions. Each group has 3 multiple choice questions based on a paragraph. Each question has 4 choices (A), (B), (C) and (D) for its answer, out of which **ONLY ONE** is correct.

Paragraph for question Nos. 33 to 35

A fair die is tossed repeatedly until a six is obtained. Let X denote the number of tosses required.

33. The probability that $X = 3$ equals

(A) $\frac{25}{216}$

(B) $\frac{25}{36}$

(C) $\frac{5}{36}$

(D) $\frac{125}{216}$

Sol. (A)

$$P(X = 3) = \left(\frac{5}{6}\right)\left(\frac{5}{6}\right)\frac{1}{6} = \frac{25}{216}.$$

34. The probability that $X \geq 3$ equals

(A) $\frac{125}{216}$

(B) $\frac{25}{36}$

(C) $\frac{5}{36}$

(D) $\frac{25}{216}$

Sol. (B)

$$P(X \leq 2) = \frac{1}{6} + \frac{5}{6} \times \frac{1}{6} = \frac{11}{36}$$

$$\text{Required probability} = 1 - \frac{11}{36} = \frac{25}{36}.$$

35. The conditional probability that $X \geq 6$ given $X > 3$ equals

- (A) $\frac{125}{216}$ (B) $\frac{25}{216}$
(C) $\frac{5}{36}$ (D) $\frac{25}{36}$

Sol. (D)

For $X \geq 6$, the probability is

$$\frac{5^5}{6^6} + \frac{5^6}{6^7} + \dots = \frac{5^5}{6^6} \left(\frac{1}{1 - 5/6} \right) = \left(\frac{5}{6} \right)^5$$

For $X > 3$

$$\frac{5^3}{6^4} + \frac{5^4}{6^5} + \frac{5^5}{6^6} + \dots = \left(\frac{5}{6} \right)^3$$

Hence the conditional probability $\frac{(5/6)^6}{(5/6)^3} = \frac{25}{36}$.

Paragraph for question Nos. 36 to 38

Let \mathcal{M} be the set of all 3×3 symmetric matrices all of whose entries are either 0 or 1. Five of these entries are 1 and four of them are 0.

36. The number of matrices in \mathcal{M} is
(A) 12 (B) 6
(C) 9 (D) 3

Sol. (A)

If two zero's are the entries in the diagonal, then

$${}^3C_2 \times {}^3C_1$$

If all the entries in the principle diagonal is 1, then

$3C_1$

\Rightarrow Total matrix = 12.

37. The number of matrices A in \mathcal{M} for which the system of linear equations $A \begin{bmatrix} x \\ y \\ z \end{bmatrix} = \begin{bmatrix} 1 \\ 0 \\ 0 \end{bmatrix}$ has a unique solution, is
(A) less than 4 (B) at least 4 but less than 7
(C) at least 7 but less than 10 (D) at least 10

Sol. (B)

$$\begin{bmatrix} 0 & a & b \\ a & 0 & c \\ b & c & 1 \end{bmatrix}$$

either $b = 0$ or $c = 0 \Rightarrow |A| \neq 0$

\Rightarrow 2 matrices

$$\begin{bmatrix} 0 & a & b \\ a & 1 & c \\ b & c & 0 \end{bmatrix}$$

either $a = 0$ or $c = 0 \Rightarrow |A| \neq 0$

\Rightarrow 2 matrices

$$\begin{bmatrix} 1 & a & b \\ a & 0 & c \\ b & c & 0 \end{bmatrix}$$

either $a=0$ or $b=0 \Rightarrow |A| \neq 0$
 \Rightarrow 2 matrices.

$$\begin{bmatrix} 1 & a & b \\ a & 1 & c \\ b & c & 1 \end{bmatrix}$$

If $a=b=0 \Rightarrow |A|=0$

If $a=c=0 \Rightarrow |A|=0$

If $b=c=0 \Rightarrow |A|=0$

\Rightarrow there will be only 6 matrices.

38. The number of matrices A in $\mathbb{R}^{3 \times 3}$ for which the system of linear equations $A \begin{bmatrix} x \\ y \\ z \end{bmatrix} = \begin{bmatrix} 1 \\ 0 \\ 0 \end{bmatrix}$ is inconsistent, is

(A) 0
 (C) 2

(B) more than 2
 (D) 1

Sol.

(B)

The six matrix A for which $|A|=0$ are

$$\begin{bmatrix} 0 & 0 & 1 \\ 0 & 0 & 1 \\ 1 & 1 & 1 \end{bmatrix} \Rightarrow \text{inconsistent.}$$

$$\begin{bmatrix} 0 & 1 & 0 \\ 1 & 1 & 1 \\ 0 & 1 & 0 \end{bmatrix} \Rightarrow \text{inconsistent.}$$

$$\begin{bmatrix} 1 & 1 & 1 \\ 1 & 0 & 0 \\ 1 & 0 & 0 \end{bmatrix} \Rightarrow \text{infinite solutions.}$$

$$\begin{bmatrix} 1 & 1 & 0 \\ 1 & 1 & 0 \\ 0 & 0 & 1 \end{bmatrix} \Rightarrow \text{inconsistent.}$$

$$\begin{bmatrix} 1 & 0 & 1 \\ 0 & 1 & 0 \\ 1 & 0 & 1 \end{bmatrix} \Rightarrow \text{inconsistent.}$$

$$\begin{bmatrix} 1 & 0 & 0 \\ 0 & 1 & 1 \\ 0 & 1 & 1 \end{bmatrix} \Rightarrow \text{infinite solutions.}$$

SECTION – IV Matrix – Match Type

This section contains 2 questions. Each question contains statements given in two columns, which have to be matched. The statement in **Column I** are labelled A, B, C and D, while the statements in **Column II** are labelled p, q, r, s and t. Any given statement in **Column I** can have correct matching with **ONE OR MORE** statement (s) in

Column II. The appropriate bubbles corresponding to the answers to these questions have to be darkened as illustrated in the following example:

If the correct matches are A – p, s and t; B – q and r; C – p and q; and D – s and t; then the correct darkening of bubbles will look like the following.

	p	q	r	s	t
A	<input checked="" type="radio"/>	<input type="radio"/>	<input type="radio"/>	<input checked="" type="radio"/>	<input checked="" type="radio"/>
B	<input type="radio"/>	<input checked="" type="radio"/>	<input checked="" type="radio"/>	<input type="radio"/>	<input type="radio"/>
C	<input checked="" type="radio"/>	<input checked="" type="radio"/>	<input type="radio"/>	<input type="radio"/>	<input type="radio"/>
D	<input type="radio"/>	<input type="radio"/>	<input type="radio"/>	<input checked="" type="radio"/>	<input checked="" type="radio"/>

39. Match the conics in **Column I** with the statements/expressions in **Column II**.

	Column I	Column II
(A)	Circle	(p) The locus of the point (h, k) for which the line $hx + ky = 1$ touches the circle $x^2 + y^2 = 4$
(B)	parabola	(q) Points z in the complex plane satisfying $ z + 2 - z - 2 = \pm 3$
(C)	Ellipse	(r) Points of the conic have parametric representation $x = \sqrt{3} \left(\frac{1-t^2}{1+t^2} \right)$, $y = \frac{2t}{1+t^2}$
(D)	Hyperbola	(s) The eccentricity of the conic lies in the interval $1 \leq e < \infty$ (t) Points z in the complex plane satisfying $\operatorname{Re}(z + 1)^2 = z ^2 + 1$

Sol. (A) → (p) (B) → (s, t) (C) → (r) (D) → (q, s)

(p). $\frac{1}{k^2} = 4 \left(1 + \frac{h^2}{k^2} \right)$
 $\Rightarrow 1 = 4(k^2 + h^2)$
 $\therefore h^2 + k^2 = \left(\frac{1}{2} \right)^2$ which is a circle.

(q). If $|z - z_1| - |z - z_2| = k$ where $k < |z_1 - z_2|$
the locus is a hyperbola.

(r). Let $t = \tan \alpha$
 $\Rightarrow x = \sqrt{3} \cos 2\alpha$ and $y = \sin 2\alpha$
or $\cos 2\alpha = \frac{x}{\sqrt{3}}$ and $\sin 2\alpha = y$
 $\therefore \frac{x^2}{3} + y^2 = \sin^2 2\alpha + \cos^2 2\alpha = 1$ which is an ellipse.

(s). If eccentricity is $[1, \infty)$, then the conic can be a parabola (if $e = 1$) and a hyperbola if $e \in (1, \infty)$.

(t). Let $z = x + iy$; $x, y \in \mathbb{R}$
 $\Rightarrow (x + 1)^2 - y^2 = x^2 + y^2 + 1$
 $\Rightarrow y^2 = x$; which is a parabola.

40. Match the statements/expressions in **Column I** with the open intervals in **Column II**.

	Column I	Column II
(A)	Interval contained in the domain of definition of non-zero solutions of the differential equation $(x - 3)^2 y' + y = 0$	(p) $\left(-\frac{\pi}{2}, \frac{\pi}{2} \right)$

- | | |
|---|--|
| (B) Interval containing the value of the integral
$\int_1^5 (x-1)(x-2)(x-3)(x-4)(x-5) dx$ | (q) $\left(0, \frac{\pi}{2}\right)$ |
| (C) Interval in which at least one of the points of local maximum of $\cos^2 x + \sin x$ lies | (r) $\left(\frac{\pi}{8}, \frac{5\pi}{4}\right)$ |
| (D) Interval in which $\tan^{-1}(\sin x + \cos x)$ is increasing | (s) $\left(0, \frac{\pi}{8}\right)$ |
| | (t) $(-\pi, \pi)$ |

Sol. (A) \rightarrow (p, q, s) (B) \rightarrow (p, t) (C) \rightarrow (p, q, r, t) (D) \rightarrow (s)

(A). $(x-3)^2 \frac{dy}{dx} + y = 0$

$$\int \frac{dx}{(x-3)^2} = -\int \frac{dy}{y}$$

$$\Rightarrow \frac{1}{x-3} = \ln|y| + c$$

so domain is $\mathbb{R} - \{3\}$.

(B). Put $x = t + 3$

$$\int_{-2}^2 (t+2)(t+1)t(t-1)(t-2) dt = \int_{-2}^2 t(t^2-1)(t^2-4) dt = 0 \text{ (being odd function)}$$

(C). $f(x) = \frac{5}{4} - \left(\sin x - \frac{1}{2}\right)^2$

Maximum value occurs when $\sin x = \frac{1}{2}$

(D). $f(x) > 0$ if $\cos x > \sin x$.

PART III: PHYSICS

SECTION - I

Single Correct Choice Type

This section contains 8 multiple choice questions. Each question has 4 choices (A), (B), (C) and (D) for its answer, out of which **ONLY ONE** is correct.

41. Look at the drawing given in the figure which has been drawn with ink of uniform line-thickness. The mass of ink used to draw each of the two inner circles, and each of the two line segments is m . The mass of the ink used to draw the outer circle is $6m$. The coordinates of the centres of the different parts are: outer circle $(0, 0)$ left inner circle $(-a, a)$, right inner circle (a, a) , vertical line $(0, 0)$ and horizontal line $(0, -a)$. The y -coordinate of the centre of mass of the ink in this drawing is

(A) $\frac{a}{10}$

(B) $\frac{a}{8}$

(C) $\frac{a}{12}$

(D) $\frac{a}{3}$

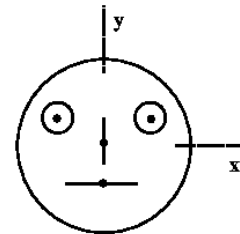

Sol. (A)

$$Y_{cm} = \frac{6m \times 0 + m \times a + m \times a + m \times 0 + m \times (-a)}{10 \times m}$$

$$Y_{cm} = \frac{a}{10}$$

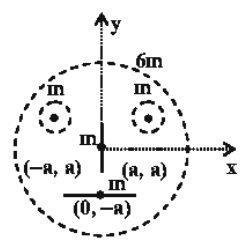

42. The figure shows certain wire segments joined together to form a coplanar loop. The loop is placed in a perpendicular magnetic field in the direction going into the plane of the figure. The magnitude of the field increases with time. I_1 and I_2 are the currents in the segments **ab** and **cd**. Then,
 (A) $I_1 > I_2$
 (B) $I_1 < I_2$
 (C) I_1 is in the direction **ba** and I_2 is in the direction **cd**
 (D) I_1 is in the direction **ab** and I_2 is in the direction **dc**

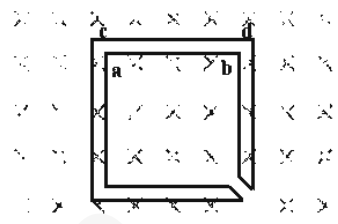

Sol. (D)
 According to Lenz's law, current will be in anticlockwise sense as magnetic field is increasing into the plane of paper.

43. Two small particles of equal masses start moving in opposite directions from a point A in a horizontal circular orbit. Their tangential velocities are v and $2v$ respectively, as shown in the figure. Between collisions, the particles move with constant speeds. After making how many elastic collisions, other than that at A, these two particles will again reach the point A?
 (A) 4
 (B) 3
 (C) 2
 (D) 1

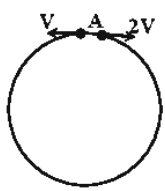

Sol. (C)
 Velocity will exchange after each collision

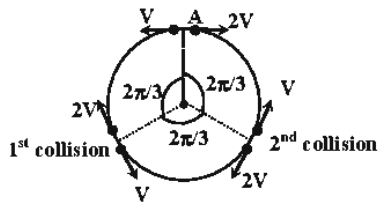

44. A disk of radius $a/4$ having a uniformly distributed charge $6C$ is placed in the x - y plane with its centre at $(-a/2, 0, 0)$. A rod of length a carrying a uniformly distributed charge $8C$ is placed on the x -axis from $x = a/4$ to $x = 5a/4$. Two point charges $-7C$ and $3C$ are placed at $(a/4, -a/4, 0)$ and $(-3a/4, 3a/4, 0)$, respectively. Consider a cubical surface formed by six surfaces $x = \pm a/2, y = \pm a/2, z = \pm a/2$. The electric flux through this cubical surface is
 (A) $\frac{-2C}{\epsilon_0}$
 (B) $\frac{2C}{\epsilon_0}$
 (C) $\frac{10C}{\epsilon_0}$
 (D) $\frac{12C}{\epsilon_0}$

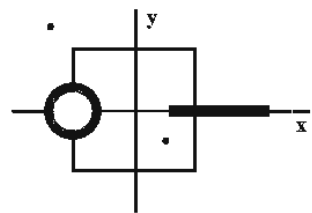

Sol. (A)
 Total charge enclosed by cube is $-2C$. Hence electric flux through the cube is $\frac{-2C}{\epsilon_0}$.

45. Three concentric metallic spherical shells of radii $R, 2R, 3R$, are given charges Q_1, Q_2, Q_3 , respectively. It is found that the surface charge densities on the outer surfaces of the shells are equal. Then, the ratio of the charges given to the shells, $Q_1 : Q_2 : Q_3$, is
 (A) 1 : 2 : 3 (B) 1 : 3 : 5
 (C) 1 : 4 : 9 (D) 1 : 8 : 18

Sol. (B)

$$\frac{Q_1}{4\pi R^2} = \frac{Q_1 + Q_2}{4\pi(2R)^2} = \frac{Q_1 + Q_2 + Q_3}{4\pi(3R)^2}$$

$$\Rightarrow Q_1 : Q_2 : Q_3 :: 1 : 3 : 5$$

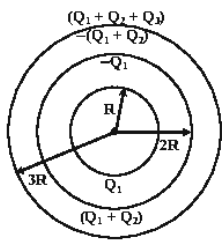

46. The x - t graph of a particle undergoing simple harmonic motion is shown below. The acceleration of the particle at $t = 4/3$ s is
 (A) $\frac{\sqrt{3}}{32} \pi^2 \text{ cm/s}^2$ (B) $-\frac{\pi^2}{32} \text{ cm/s}^2$
 (C) $\frac{\pi^2}{32} \text{ cm/s}^2$ (D) $-\frac{\sqrt{3}}{32} \pi^2 \text{ cm/s}^2$

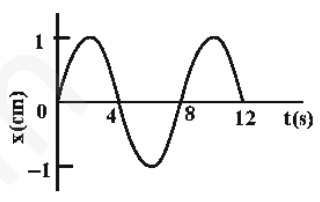

Sol. (D)
 The given motion is represented by

$$x = 1 \sin(\pi/4)t$$

$$\frac{d^2x}{dt^2} = -\frac{\pi^2}{16} \sin(\pi/4)t$$
 At $t = 4/3$ sec,

$$\frac{d^2x}{dt^2} = -\frac{\sqrt{3}}{32} \pi^2 \text{ cm/s}^2.$$

47. A ball is dropped from a height of 20 m above the surface of water in a lake. The refractive index of water is $4/3$. A fish inside the lake, in the line of fall of the ball, is looking at the ball. At an instant, when the ball is 12.8 m above the water surface, the fish sees the speed of ball as
 (A) 9 m/s (B) 12 m/s
 (C) 16 m/s (D) 21.33 m/s

Sol. (C)

$$v_{\text{ball}}^2 = 2 \times 10 \times 7.2$$

$$\Rightarrow v = 12 \text{ m/s}$$

$$x_{\text{image of ball}} = \frac{4}{3} x_{\text{ball}}$$

$$v_{\text{image of ball}} = \frac{4}{3} v_{\text{ball}} = \frac{4}{3} \times 12 = 16 \text{ m/s}$$

48. A block of base $10 \text{ cm} \times 10 \text{ cm}$ and height 15 cm is kept on an inclined plane. The coefficient of friction between them is $\sqrt{3}$. The inclination θ of this inclined plane from the horizontal plane is gradually increased from 0° . Then
 (A) at $\theta = 30^\circ$, the block will start sliding down the plane
 (B) the block will remain at rest on the plane up to certain θ and then it will topple
 (C) at $\theta = 60^\circ$, the block will start sliding down the plane and continue to do so at higher angles
 (D) at $\theta = 60^\circ$, the block will start sliding down the plane and on further increasing θ , it will topple at certain θ

- Sol. (B)
For sliding, $\tan \theta \geq \sqrt{3}$ (≈ 1.732)
For toppling, $\tan \theta \geq \frac{2}{3}$ (≈ 0.67)

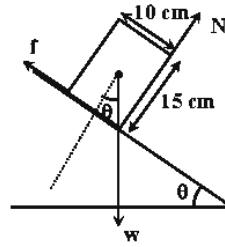

F.B.D. at just toppling condition.

SECTION – II

Multiple Correct Choice Type

This section contains 4 multiple choice questions. Each question has 4 choices (A), (B), (C) and (D) for its answer, out of which **ONE OR MORE** is /are correct.

49. For the circuit shown in the figure

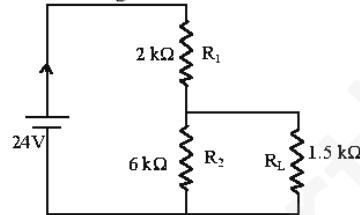

- (A) the current I through the battery is 7.5 mA
(B) the potential difference across R_L is 18 V
(C) ratio of powers dissipated in R_1 and R_2 is 3
(D) if R_1 and R_2 are interchanged, magnitude of the power dissipated in R_L will decrease by a factor of 9.

- Sol. (A & D)
 $24 - 2 \times 10^3 I - 6 \times 10^3 (I - i) = 0$
 $24 - 2 \times 10^3 I - 1.5 \times 10^3 i = 0$
Hence $I = 7.5$ mA
 $i = 6$ mA

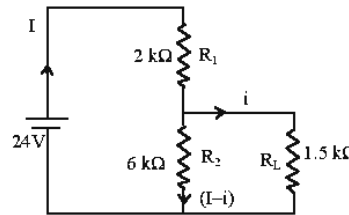

- $24 - 6 \times 10^3 I' - 2 \times 10^3 (I' - i') = 0$
 $24 - 6 \times 10^3 I' - 1.5 \times 10^3 i' = 0$
 $I' = 3.5$ mA
 $i' = 2$ mA
 $\frac{P_1}{P_2} = \frac{6^2}{2^2} = 9$

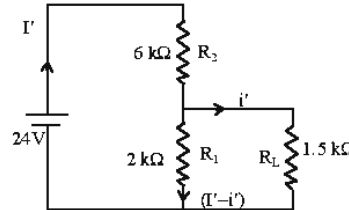

50. C_v and C_p denote the molar specific heat capacities of a gas at constant volume and constant pressure, respectively. Then
(A) $C_p - C_v$ is larger for a diatomic ideal gas than for a monoatomic ideal gas.
(B) $C_p + C_v$ is larger for a diatomic ideal gas than for a monoatomic ideal gas.
(C) C_p/C_v is larger for a diatomic ideal gas than for a monoatomic ideal gas.
(D) $C_p \cdot C_v$ is larger for a diatomic ideal gas than for a monoatomic ideal gas.

Sol. (B & D)

For Monoatomic gas

$$C_v = \frac{3}{2}R, \quad C_p = \frac{5}{2}R$$

For diatomic gas

$$C_v = \frac{5}{2}R, \quad C_p = \frac{7}{2}R$$

51. A student performed the experiment of determination of focal length of a concave mirror by $u - v$ method using an optical bench of length 1.5 meter. The focal length of the mirror used is 24 cm. The maximum error in the location of the image can be 0.2 cm. The 5 sets of (u, v) values recorded by the student (in cm) are: (42, 56), (48, 48), (60, 40), (66, 33), (78, 39). The data set(s) that **cannot** come from experiment and is (are) incorrectly recorded, is (are)
- (A) (42, 56) (B) (48, 48)
 (C) (66, 33) (D) (78, 39)

Sol. (C & D)

$$\frac{1}{f} = \frac{1}{v} + \frac{1}{u} \quad (\text{mirror formula})$$

$$f = -24 \text{ cm}$$

52. If the resultant of all the external forces acting on a system of particles is zero, then from an inertial frame, one can surely say that
- (A) linear momentum of the system does not change in time
 (B) kinetic energy of the system does not change in time
 (C) angular momentum of the system does not change in time
 (D) potential energy of the system does not change in time

Sol. (A)

Linear momentum remains constant if net external force on the system of particles is zero.

SECTION –III

Comprehension Type

This section contains 2 groups of questions. Each group has 3 multiple choice questions based on a paragraph. Each question has 4 choices (A), (B), (C) and (D) for its answer, out of which **ONLY ONE** is correct.

Paragraph for Question Nos. 53 to 55

When a particle is restricted to move along x -axis between $x = 0$ and $x = a$, where a is of nanometer dimension, its energy can take only certain specific values. The allowed energies of the particle moving in such a restricted region, correspond to the formation of standing waves with nodes at its ends $x=0$ and $x=a$. The wavelength of this standing wave is related to the linear momentum p of the particle according to the de Broglie relation. The energy of the particle of mass m is related to its linear momentum as $E = p^2/2m$. Thus, the energy of the particle can be denoted by a quantum number ' n ' taking values 1, 2, 3, ($n = 1$, called the ground state) corresponding to the number of loops in the standing wave.

Use the model described above to answer the following three questions for a particle moving in the line $x = 0$ to $x = a$. Take $h = 6.6 \times 10^{-34}$ Js and $e = 1.6 \times 10^{-19}$ C.

53. The allowed energy for the particle for a particular value of n is proportional to
- (A) a^{-2} (B) $a^{-3/2}$
 (C) a^{-1} (D) a^2

Sol. (A)

$$a = \frac{n\lambda}{2} \Rightarrow \lambda = \frac{2a}{n}$$

$$\lambda_{\text{deBrogie}} = \frac{h}{p}$$

$$\frac{2a}{n} = \frac{h}{p} \Rightarrow p = \frac{nh}{2a}$$

$$E = \frac{p^2}{2m} = \frac{n^2 h^2}{8a^2 m}$$

$$\Rightarrow E \propto 1/a^2$$

54. If the mass of the particle is $m = 1.0 \times 10^{-30}$ kg and $a = 6.6$ nm, the energy of the particle in its ground state is closest to
 (A) 0.8 meV (B) 8 meV
 (C) 80 meV (D) 800 meV

Sol. (B)

$$E = \frac{h^2}{8a^2 m} = \frac{(6.6 \times 10^{-34})^2}{8 \times (6.6 \times 10^{-9})^2 \times 10^{-30} \times 1.6 \times 10^{-19}} = 8 \text{ meV.}$$

55. The speed of the particle that can take discrete values is proportional to
 (A) $n^{-3/2}$ (B) n^1
 (C) $n^{1/2}$ (D) n

Sol. (D)

$$mv = \frac{nh}{2a}$$

$$v = \frac{nh}{2am}$$

$$v \propto n$$

Paragraph for Question Nos. 56 to 58

Scientists are working hard to develop nuclear fusion reactor. Nuclei of heavy hydrogen, ${}^2_1\text{H}$ known as deuteron and denoted by D can be thought of as a candidate for fusion reactor. The D-D reaction is ${}^2_1\text{H} + {}^2_1\text{H} \rightarrow {}^3_2\text{He} + n + \text{energy}$. In the core of fusion reactor, a gas of heavy hydrogen is fully ionized into deuteron nuclei and electrons. This collection of ${}^2_1\text{H}$ nuclei and electrons is known as plasma. The nuclei move randomly in the reactor core and occasionally come close enough for nuclear fusion to take place. Usually, the temperatures in the reactor core are too high and no material wall can be used to confine the plasma. Special techniques are used which confine the plasma for a time t_0 before the particles fly away from the core. If n is the density (number/volume) of deuterons, the product nt_0 is called Lawson number. In one of the criteria, a reactor is termed successful if Lawson number is greater than 5×10^{14} s/cm³.

It may be helpful to use the following: Boltzmann constant $k = 8.6 \times 10^{-5}$ eV/K; $\frac{e^2}{4\pi\epsilon_0} = 1.44 \times 10^{-9}$ eVm.

56. In the core of nuclear fusion reactor, the gas becomes plasma because of
 (A) strong nuclear force acting between the deuterons
 (B) Coulomb force acting between the deuterons
 (C) Coulomb force acting between deuteron-electron pairs
 (D) the high temperature maintained inside the reactor core

Sol. (D)

57. Assume that two deuteron nuclei in the core of fusion reactor at temperature T are moving towards each other, each with kinetic energy 1.5 kT , when the separation between them is large enough to neglect Coulomb potential energy. Also neglect any interaction from other particles in the core. The minimum temperature T required for them to reach a separation of $4 \times 10^{-15} \text{ m}$ is in the range
- (A) $1.0 \times 10^9 \text{ K} < T < 2.0 \times 10^9 \text{ K}$ (B) $2.0 \times 10^9 \text{ K} < T < 3.0 \times 10^9 \text{ K}$
(C) $3.0 \times 10^9 \text{ K} < T < 4.0 \times 10^9 \text{ K}$ (D) $4.0 \times 10^9 \text{ K} < T < 5.0 \times 10^9 \text{ K}$

Sol. (A)

$$2 \times 1.5 \text{ kT} = \frac{e^2}{4\pi\epsilon_0 d} \text{ (conservation of energy)}$$

$$T = 1.4 \times 10^9 \text{ K}$$

58. Results of calculations for four different designs of a fusion reactor using D-D reaction are given below. Which of these is most promising based on Lawson criterion?
- (A) deuteron density = $2.0 \times 10^{12} \text{ cm}^{-3}$, confinement time = $5.0 \times 10^{-3} \text{ s}$
(B) deuteron density = $8.0 \times 10^{14} \text{ cm}^{-3}$, confinement time = $9.0 \times 10^{-1} \text{ s}$
(C) deuteron density = $4.0 \times 10^{23} \text{ cm}^{-3}$, confinement time = $1.0 \times 10^{-11} \text{ s}$
(D) deuteron density = $1.0 \times 10^{24} \text{ cm}^{-3}$, confinement time = $4.0 \times 10^{-12} \text{ s}$

Sol. (B)

$$n t_0 > 5 \times 10^{14} \text{ (as given)}$$

SECTION – IV
Matrix-Match Type

This section contains 2 questions. Each question contains statements given in two columns which have to be matched. The statements in **Column I** are labelled A, B, C and D, while the statements in **Column II** are labeled p, q, r, s and t. Any given statement in **Column I** can have correct matching with **ONE OR MORE** statement(s) in **Column II**. The appropriate bubbles corresponding to the answers to these questions have to be darkened as illustrated in the following example:

If the correct matches are A-p, s and t; B-q and r; C-p and q; and D-s and t; then the correct darkening of bubbles will look like the following.

	p	q	r	s	t
A	<input checked="" type="radio"/>	<input checked="" type="radio"/>	<input type="radio"/>	<input checked="" type="radio"/>	<input checked="" type="radio"/>
B	<input type="radio"/>	<input checked="" type="radio"/>	<input checked="" type="radio"/>	<input type="radio"/>	<input type="radio"/>
C	<input checked="" type="radio"/>	<input checked="" type="radio"/>	<input type="radio"/>	<input type="radio"/>	<input type="radio"/>
D	<input type="radio"/>	<input type="radio"/>	<input type="radio"/>	<input checked="" type="radio"/>	<input checked="" type="radio"/>

59. **Column II** shows five systems in which two objects are labelled as X and Y. Also in each case a point P is shown. **Column I** gives some statements about X and/or Y. Match these statements to the appropriate system(s) from **Column II**.

Column – I

- (A) The force exerted by X on Y has a magnitude Mg .
- (B) The gravitational potential energy of X is continuously increasing.
- (C) Mechanical energy of the system X + Y is continuously decreasing.
- (D) The torque of the weight of Y about point P is zero.

Column II

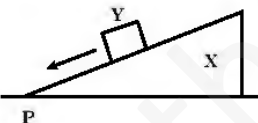
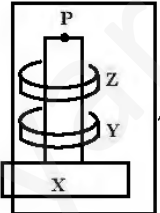
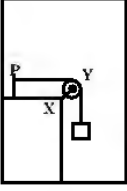
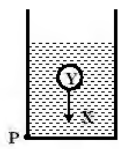
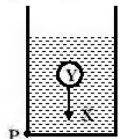
- (p)  Block Y of mass M left on a fixed inclined plane X, slides on it with a constant velocity.
- (q)  Two ring magnets Y and Z, each of mass M, are kept in frictionless vertical plastic stand so that they repel each other. Y rests on the base X and Z hangs in air in equilibrium. P is the topmost point of the stand on the common axis of the two rings. The whole system is in a lift that is going up with a constant velocity.
- (r)  A pulley Y of mass m_0 is fixed to a table through a clamp X. A block of mass M hangs from a string that goes over the pulley and is fixed at point P of the table. The whole system is kept in a lift that is going down with a constant velocity.
- (s)  A sphere Y of mass M is put in a nonviscous liquid X kept in a container at rest. The sphere is released and it moves down in the liquid.
- (t)  A sphere Y of mass M is falling with its terminal velocity in a viscous liquid X kept in a container.

Sol. (A) → (p, t), (B) → (q, s, t), (C) → (p, r, t), (D) → (q)

60. Six point charges, each of the same magnitude q , are arranged in different manners as shown in **Column II**. In each case, a point M and a line PQ passing through M are shown. Let E be the electric field and V be the electric potential at M (potential at infinity is zero) due to the given charge distribution when it is at rest. Now, the whole system is set into rotation with a constant angular velocity about the line PQ . Let B be the magnetic field at M and μ be the magnetic moment of the system in this condition. Assume each rotating charge to be equivalent to a steady current.

- Column – I**
- (A) $E = 0$
 - (B) $V \neq 0$
 - (C) $B = 0$
 - (D) $\mu \neq 0$

Column II

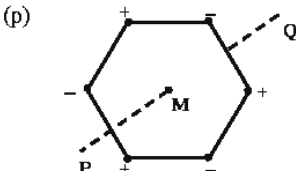
(p)  Charges are at the corners of a regular hexagon. M is at the centre of the hexagon. PQ is perpendicular to the plane of the hexagon.

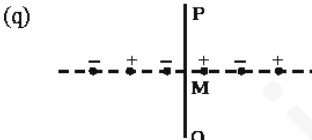
(q)  Charges are on a line perpendicular to PQ at equal intervals. M is the mid-point between the two innermost charges.

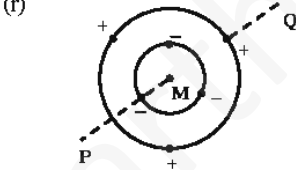
(r)  Charges are placed on two coplanar insulating rings at equal intervals. M is the common centre of the rings. PQ is perpendicular to the plane of the rings.

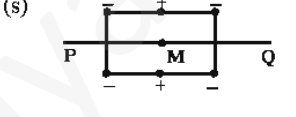
(s)  Charges are placed at the corners of a rectangle of sides a and $2a$ and at the mid points of the longer sides. M is at the centre of the rectangle. PQ is parallel to the longer sides.

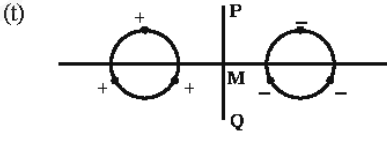
(t)  Charges are placed on two coplanar, identical insulating rings at equal intervals. M is the mid points between the centres of the rings. PQ is perpendicular to the line joining the centers and coplanar to the rings.

Sol. (A) → (p, r, s), (B) → (r, s), (C) → (p, q, t), (D) → (r, s)

* * * * *