

DO NOT OPEN THIS TEST BOOKLET UNTIL YOU ARE ASKED TO DO SO

T.B.C. : B-FRF-M-DDA

Test Booklet Series

Serial No.

TEST BOOKLET

ELECTRICAL ENGINEERING

Paper I

A

Time Allowed : Two Hours

Maximum Marks : 200

INSTRUCTIONS

1. IMMEDIATELY AFTER THE COMMENCEMENT OF THE EXAMINATION, YOU SHOULD CHECK THAT THIS TEST BOOKLET *DOES NOT* HAVE ANY UNPRINTED OR TORN OR MISSING PAGES OR ITEMS, ETC. IF SO, GET IT REPLACED BY A COMPLETE TEST BOOKLET.
 2. PLEASE NOTE THAT IT IS THE CANDIDATE'S RESPONSIBILITY TO ENCODE AND FILL IN THE ROLL NUMBER AND TEST BOOKLET SERIES CODE A, B, C OR D CAREFULLY AND WITHOUT ANY OMISSION OR DISCREPANCY AT THE APPROPRIATE PLACES IN THE *OMR* ANSWER SHEET. ANY OMISSION/DISCREPANCY WILL RENDER THE ANSWER SHEET LIABLE FOR REJECTION.
 3. You have to enter your Roll Number on the Test Booklet in the Box provided alongside. *DO NOT* write *anything else* on the Test Booklet.
-
4. This Test Booklet contains **120** items (questions). Each item comprises four responses (answers). You will select the response which you want to mark on the Answer Sheet. In case, you feel that there is more than one correct response, mark the response which you consider the best. In any case, choose *ONLY ONE* response for each item.
 5. You have to mark your responses *ONLY* on the separate Answer Sheet provided. See directions in the Answer Sheet.
 6. All items carry equal marks.
 7. Before you proceed to mark in the Answer Sheet the response to various items in the Test Booklet, you have to fill in some particulars in the Answer Sheet as per instructions sent to you with your Admission Certificate.
 8. After you have completed filling in all your responses on the Answer Sheet and the examination has concluded, you should hand over to the Invigilator *only the Answer Sheet*. You are permitted to take away with you the Test Booklet.
 9. Sheets for rough work are appended in the Test Booklet at the end.
 10. **Penalty for wrong answers :**
THERE WILL BE PENALTY FOR WRONG ANSWERS MARKED BY A CANDIDATE.
 - (i) There are four alternatives for the answer to every question. For each question for which a wrong answer has been given by the candidate, **one-third (0.33)** of the marks assigned to that question will be deducted as penalty.
 - (ii) If a candidate gives more than one answer, it will be treated as **wrong answer** even if one of the given answers happens to be correct and there will be same penalty as above to that question.
 - (iii) If a question is left blank i.e. no answer is given by the candidate, there will be **no penalty** for that question.

DO NOT OPEN THIS TEST BOOKLET UNTIL YOU ARE ASKED TO DO SO

1. A quantitative relation between induced emf and rate of change of flux linkage is known as
 - (a) Maxwell's law
 - (b) Stoke's law
 - (c) Lenz's law
 - (d) Faraday's law

2. Two identical coaxial circular loops carry the same current circulating in the same direction. If the loops approached each other, then the current in
 - (a) each one of them will increase
 - (b) both of them will remain the same
 - (c) each one of them will decrease
 - (d) one will increase while in the other the current will decrease

3. If $E = 0$ at all points on a closed surface,
 1. The electric flux through the surface is zero
 2. The total charge enclosed by the surface is zero
 3. Charge resides on the surface
 - (a) 1 and 2 only
 - (b) 1 and 3 only
 - (c) 2 and 3 only
 - (d) 1, 2 and 3

4. A long straight wire carries a current $I = 10$ A, the magnetic field at a distance of 1.59 m is
 - (a) 0.1 Am^{-1}
 - (b) 1 Am^{-1}
 - (c) 10 Am^{-1}
 - (d) 100 Am^{-1}

5. If the magnetic flux through each turn of the coil consisting of 200 turns is $(t^2 - 3t)$ milli-Webers, where t is in seconds, then the induced emf in the coil at $t = 4$ sec is
 - (a) -1 V
 - (b) 1 V
 - (c) -0.1 V
 - (d) 0.1 V

6. The electrostatic force of repulsion between two α -particles of charges $4.0 \times 10^{-19} \text{ C}$ each, and separated by a distance of 10^{-10} cm is
(Given $\epsilon_0 = 8.854 \times 10^{-12} \text{ Nm}^2/\text{Coul}^2$)
 - (a) $57.6 \times 10^{-4} \text{ N}$
 - (b) $28.8 \times 10^{-4} \text{ N}$
 - (c) $14.4 \times 10^{-4} \text{ N}$
 - (d) $3.6 \times 10^{-4} \text{ N}$

7. Consider the following statements regarding magnetic materials :
 1. A diamagnetic material has no permanent dipole
 2. Paramagnetic material has anti parallel orientation of equal moments with neighbouring dipoles
 3. Ferrimagnetic material has anti parallel orientation of unequal moments between neighbouring dipoles
 4. Anti ferromagnetic material has negligible interaction between neighbouring dipoles

Which of these statements are correct ?

 - (a) 1 and 2
 - (b) 3 and 4
 - (c) 2 and 4
 - (d) 1 and 3

8. Consider the following statements regarding hysteresis loops of hard and soft magnetic materials :

1. Hysteresis loss of hard magnetic material will be less than that of soft material
2. Coercivity of hard material will be greater than that of soft material
3. Retentivity of the two materials will always be equal

Which of these statements are correct ?

- (a) 1, 2 and 3
- (b) 2 only
- (c) 3 only
- (d) 1 and 3 only

9. The inconsistency of continuity equation for time varying fields was corrected by Maxwell and the correction applied was

- (a) Ampere's law, $\frac{\partial D}{\partial t}$
- (b) Gauss's law, J
- (c) Faraday's law, $\frac{\partial B}{\partial t}$
- (d) Ampere's law, $\frac{\partial P}{\partial t}$

10. Loss-tangent in plane waves in lossy dielectrics will be

- (a) proportional to the Y component of the magnetic field intensity (H_Y)
- (b) inversely proportional to the Y component of the magnetic field intensity (H_Y)
- (c) inversely proportional to the X component of the magnetic field intensity (H_X)
- (d) proportional to X component of the magnetic field intensity (H_X)

11. Transverse Electro-magnetic waves are characterized by

- (a) During wave propagation in Z -direction, the components of H and E are transverse 60° to the direction of propagation of the waves
- (b) During wave propagation in Z -direction, the components of H and E are transverse to the direction of propagation of the waves
- (c) During wave propagation in Z -direction, the components of H and E are transverse 120° to the direction of propagation of the waves
- (d) None of the above

12. Orientational polarization is

- (a) inversely proportional to temperature and proportional to the square of the permanent dipole moment
- (b) proportional to temperature as well as to the square of the permanent dipole moment
- (c) proportional to temperature and inversely proportional to the square of the permanent dipole moment
- (d) inversely proportional to temperature as well as to the square of the dipole moment

13. Two media are characterized as :

1. $\epsilon_r = 1, \mu_r = 4$ and $\sigma = 0$
2. $\epsilon_r = 4, \mu_r = 4$ and $\sigma = 0$

Where : ϵ_r = relative permittivity
 μ_r = relative permeability
 σ = conductivity

The ratio of the intrinsic impedance of the media 2 to media 1 is

- (a) 2 : 1
- (b) 1 : 2
- (c) 1 : 1
- (d) 2 : 2

14. A transmission line of characteristic impedance 50Ω is terminated at one end by $+j50 \Omega$. The VSWR produced by the line is
- +1
 - 0
 - ∞
 - $+j$
15. A loss-less transmission line having characteristic impedance Z_0 is terminated in a load of Z_R . If the value of Z_R is exactly half of Z_0 then reflection coefficient Γ_L is
- $\frac{1}{3}$
 - $\frac{2}{3}$
 - $-\frac{1}{3}$
 - $-\frac{2}{3}$
16. The drift velocity of electron in Silicon
- is proportional to electric field for all values of electric field
 - is independent of electric field
 - increases at lower values and decreases at higher values of electric field
 - increases linearly with electric field at low values and gradually saturates at higher values of electric field
17. The number of $2\mu F$, 300 V capacitors needed to obtain a capacitance value of $2\mu F$ rated for 1200 V is
- 16
 - 12
 - 10
 - 08
18. Behaviour of conductors, semiconductors and insulators is explained on the basis of
- atomic structure
 - molecular structure
 - energy band structure
 - All of the above
19. In general, for a superconductor, which of the following statements is true ?
- A superconductor is a perfect paramagnetic material with the magnetic susceptibility equals to positive unity
 - A superconductor is a perfect diamagnetic material with the magnetic susceptibility equals to negative one
 - A superconductor is a perfect ferromagnetic material with the magnetic susceptibility equals to positive one
 - A superconductor is a perfect piezoelectric material with the magnetic susceptibility equals to negative unity
20. Ferro-electric materials have a
- high dielectric constant which varies non-linearly
 - low dielectric constant and is non-linear
 - high dielectric constant which varies linearly
 - low dielectric constant but linear

21. In the magnetic core the electromotive forces (emf) induced in accordance with Faraday's law of electromagnetic induction give rise to

- (a) Eddy current
- (b) Excitation current
- (c) Armature current
- (d) Field current

22. Consider the following characterizing parameters of a material :

1. Magnetic permeability
2. Electron relaxation time
3. Electron effective mass
4. Energy band gap

In case of metals, increase in one of the above parameter decreases its conductivity, while increase in another increases the conductivity. These are respectively

- (a) 1 and 3
- (b) 3 and 2
- (c) 4 and 3
- (d) 1 and 2

23. Some magnetic materials may be classified on the basis of

1. Susceptibility
2. Saturation
3. Spin arrangement
4. Nature of hysteresis loop
5. Domain structure
6. Critical temperature above which it behaves as a paramagnetic material

Which of these can be used to distinguish between ferri and ferromagnetic materials ?

- (a) 1, 3 and 4 only
- (b) 2, 3 and 6 only
- (c) 3, 4 and 5 only
- (d) 1, 2, 3, 4, 5 and 6

24. Magnetism is mainly due to only electron spin around their own axis in case of

- (a) diamagnetic materials
- (b) paramagnetic materials
- (c) ferromagnetic materials
- (d) paramagnetic and diamagnetic materials

25. For paramagnetic materials, the relative permeability is

- (a) less than unity but magnetic susceptibility is relatively small and positive
- (b) greater than unity and magnetic susceptibility is relatively small but positive
- (c) equal to unity and magnetic susceptibility is large but positive
- (d) less than unity but magnetic susceptibility is relatively large and positive

26. Permalloy and Mumetal are examples of

- (a) Silicon and Iron alloys
- (b) Nickel and Iron alloys
- (c) Cobalt and Iron alloys
- (d) Permanent magnet materials

27. When a Ferromagnetic substance is magnetized, the phenomenon of 'magnetostriction' causes
- increase in the body temperature
 - change in the permeability of the substance
 - small changes in its dimensions
 - decrease in the saturation flux-density
28. The resistivity of 'Ferrites' is very much higher than that of the Ferromagnetic metals, because
- Ferrites are chemical compounds and the electrons in them are subject to the restraint of valence forces
 - Ferrites have a low eddy current loss
 - Ferrites have a non-homogeneous molecular structure
 - Ferrites have varying flux-density inside the core
29. When the temperature exceeds the transition temperature, a ferromagnetic material becomes similar to
- anti-ferromagnetic material
 - diamagnetic material
 - ferrimagnetic material
 - paramagnetic material
30. Einstein relation is referred between
- the diffusion constant and the mobility
 - the conduction and diffusion currents
 - the conduction and diffusion voltages
 - None of the above
31. In a piezoelectric crystal oscillator, the oscillation or tuning frequency is linearly proportional to the
- mass of the crystal
 - square root of the mass of the crystal
 - square of the mass of the crystal
 - inverse of the square root of the mass of the crystal
32. Which of the following are piezoelectric substances ?
- Barium Titanate
 - Lead Titanate
 - Lead Zirconate
 - Cadmium Sulphate
- 1, 2 and 4
 - 1, 3 and 4
 - 1, 2 and 3
 - 2, 3 and 4
33. Consider the following statements :
- Fermi level in a *p*-type semiconductor lies close to the top of the valence bond.
 - The forbidden energy in Germanium at 0°K is exactly 0.75 eV.
 - When a *p-n* junction is reverse biased, then electrons and holes move away from the junction.
- Which of these statements are correct ?
- 1, 2 and 3
 - 1 and 2 only
 - 2 and 3 only
 - 1 and 3 only

34.

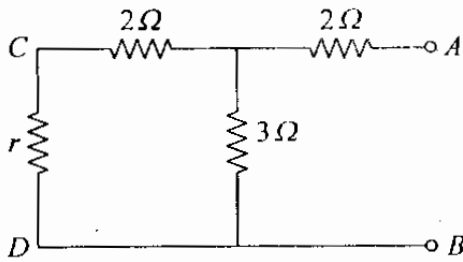

For the circuit shown above the value of r connected between C and D is such that the equivalent resistance of the circuit by looking into circuit through terminals A and B is r only. Then the value of r is

- (a) 2Ω
- (b) 4Ω
- (c) 3Ω
- (d) 6Ω

35.

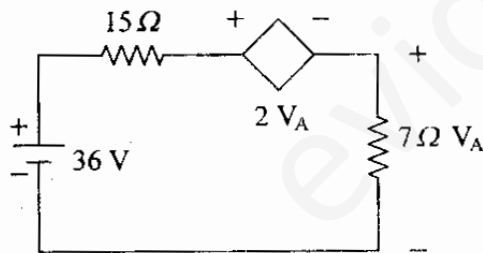

The power dissipated in the controlled source of the network shown above is

- (a) 36 W
- (b) 15 W
- (c) 07 W
- (d) 14 W

36. The resistance of a 1 kW electric heater when energized by a 230 V 1-phase AC is

- (a) 52.9Ω
- (b) 230Ω
- (c) 1000Ω
- (d) 4.2Ω

37. If an ideal voltage source and ideal current source are connected in series, the combination

- (a) has the same properties as a current source alone
- (b) has the same properties as a voltage source alone
- (c) has the same properties as the source which has a higher value
- (d) results in the branch being redundant

38. A parallel plate capacitor of area $A \text{ cm}^2$ and separating distance $a \text{ cm}$ is dipped in ethyl alcohol up to a depth of $\frac{a}{2}$. Given the dielectric constant ϵ_r of ethyl alcohol to be 25, the ratio of capacitance after dipping to that before dipping would be

- (a) $\frac{26}{50}$
- (b) $\frac{45}{50}$
- (c) $\frac{50}{26}$
- (d) $\frac{3}{1}$

39. A network N consists of resistors, independent voltage and current sources. The value of its determinant based on the loop analysis :

1. cannot be negative
2. cannot be zero
3. is independent of the values of voltage and current sources
4. dependent on the values of the resistances and the voltage and current sources

- (a) 1, 2 and 3
 (b) 1, 2 and 4
 (c) 1, 3 and 4
 (d) 2, 3 and 4

40.

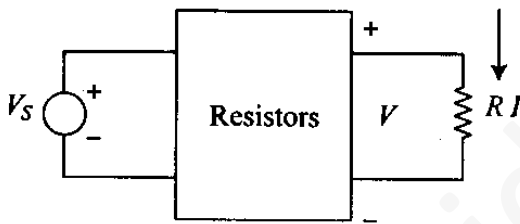

In the circuit shown above, for different values of R , the values of V and I are given, other elements remaining the same

When $R = \infty$, $V = 5 \text{ V}$

When $R = 0$, $I = 2.5 \text{ A}$

When $R = 3 \Omega$, the value of V is given by

- (a) 1 V
 (b) 5 V
 (c) 3 V
 (d) 2 V

41.

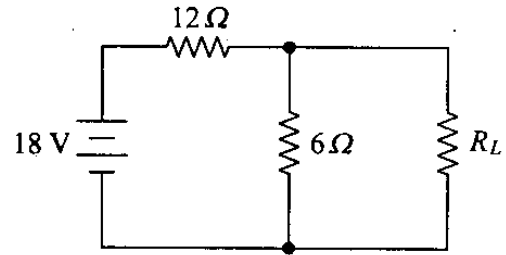

In the circuit shown above, the maximum power absorbed by the load resistance R_L is

- (a) 1.5 W
 (b) 2.25 W
 (c) 2.5 W
 (d) 5 W

42.

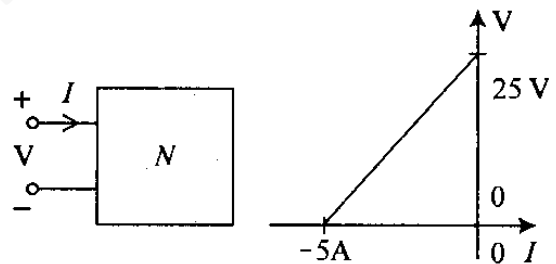

The voltage-current relationship feeding the network N is shown in the above figure. The Thevenin's equivalent of network N will have V_{Th} and R_{Th} as

- (a) 5 V and 25Ω
 (b) -25 V and 5Ω
 (c) 25 V and -5Ω
 (d) 25 V and 5Ω

43. An A.C. source of voltage E_s and an internal impedance of $Z_s = (R_s + jX_s)$ is connected to a load of impedance $Z_L = (R_L + jX_L)$. Consider the following conditions in this regard :

1. $X_L = X_s$, if only X_L is varied
2. $X_L = -X_s$ if only X_L is varied
3. $R_L = \sqrt{R_s^2 + (X_s + X_L)^2}$, if only R_L is varied
4. $|Z_L| = |Z_s|$, if the magnitude alone of Z_L is varied, keeping the phase angle fixed

The valid conditions for maximum power transfer from the source to the load are

- (a) 1, 2, 3 and 4
- (b) 1, 2 and 3 only
- (c) 1 and 4 only
- (d) 2, 3 and 4 only

44. Unit impulse response of a given system is $C(t) = -4e^{-t} + 6e^{-2t}$. The step response for $t \geq 0$ is

- (a) $-3e^{-2t} + 4e^{-t} + 1$
- (b) $3e^{-2t} + 4e^{-t} + 1$
- (c) $-3e^{-2t} - 4e^{-t} + 1$
- (d) $3e^{-2t} + 4e^{-t} - 1$

45. Elements R , L and C are connected in parallel. The impedance of the parallel combination can be expressed as

$$Z(s) = \frac{10s}{s^2 + s + 400}$$

The value of the individual elements R , L and C are

- (a) 10Ω , $40 H$ and $0.1 F$
- (b) 4Ω , $1 H$ and $0.1 F$
- (c) 10Ω , $\frac{1}{40} H$ and $0.1 F$
- (d) 1Ω , $40 H$ and $10 F$

46. A first order linear system is initially relaxed for a unit step signal $u(t)$, the response is $V(t) = (1 - e^{-3t})$, for $t > 0$. If a signal $3u(t) + \delta(t)$ is applied to the same system, the response is

- (a) $(3 - 6e^{-3t}) u(t)$
- (b) $(3 - 3e^{-3t}) u(t)$
- (c) $3u(t)$
- (d) $(3 + 3e^{-3t}) u(t)$

47.

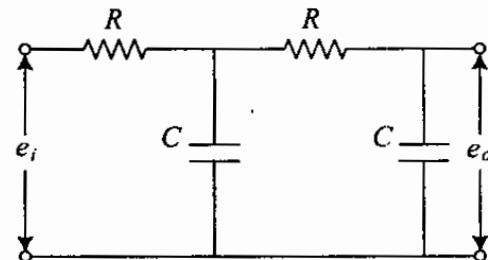

The transfer function of the network shown above is

- (a) $\frac{1}{S^2T^2 + 2ST + 1}$
- (b) $\frac{1}{S^2T^2 + 3ST + 1}$
- (c) $\frac{1}{S^2T^2 + ST + 1}$
- (d) $\frac{1}{S^2T^2 + 1}$

48.

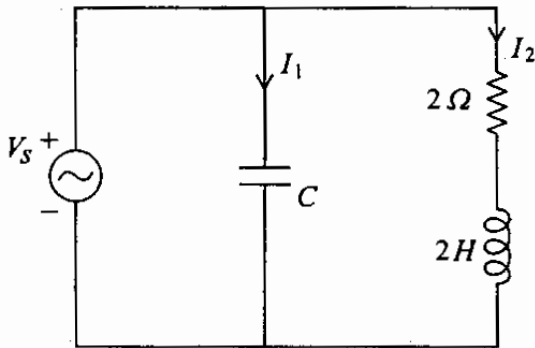

In the network shown above $V_s = 4 \cos 2t$. The value of C is so chosen that the circuit impedance is maximum. Then I_1 leads I_2 by

- (a) 45°
- (b) 90°
- (c) 0°
- (d) 135°

49. A series RLC circuit has a bandwidth of 300 rad/sec at a resonant frequency of 3000 rad/sec when excited by a voltage source of 100 V. The inductance of the coil is 0.1 H. The value of R and the voltage across C are, respectively

- (a) 10Ω and 100 V
- (b) 30Ω and 100 V
- (c) 30Ω and 1000 V
- (d) 300Ω and 1000 V

50. The circuit comprises a coil of resistance R and inductance L , in parallel with an ideal capacitor C . At the resonant frequency, the impedance of the parallel combination is

- (a) R
- (b) $\frac{LC}{R}$
- (c) $\frac{L}{RC}$
- (d) ∞

51. In RLC circuits, the current at resonance is

- (a) maximum in series RLC and minimum in parallel RLC circuit
- (b) maximum in parallel circuit and minimum in series circuit
- (c) maximum in both circuits
- (d) minimum in both circuits

52.

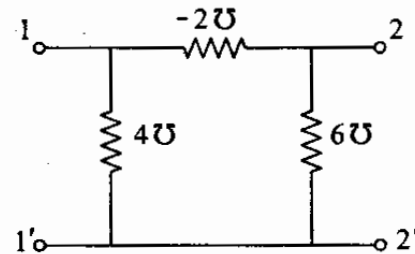

For the two port network as shown above, the parameters h_{11} and h_{21} are

- (a) 1Ω and 2Ω
- (b) 2Ω and 1
- (c) 1 and $\frac{1}{2} \Omega$
- (d) $\frac{1}{2} \Omega$ and 1

53.

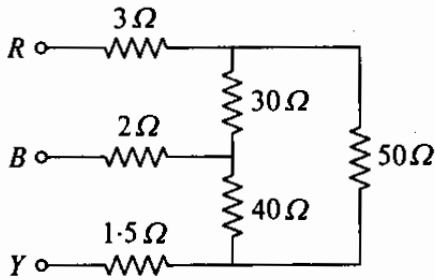

A 3-phase distribution network is as shown above. The resistance across the terminals RB , BY and RY are

- (a) 25.5Ω , 31.2Ω and 33.6Ω
- (b) 27.5Ω , 30.17Ω and 33.67Ω
- (c) 28.5Ω , 32.3Ω and 34.5Ω
- (d) 21.2Ω , 42.3Ω and 45.6Ω

54. A 3-phase load of 0.8 pf lag is supplied from a balanced 3-phase supply of phase sequence RYB . With V_{YB} as reference the current I_R will :

(Given $\cos^{-1}(0.8) = 36.76^\circ$)

- (a) In-phase with V_{YB}
- (b) Lag V_{YB} by 36.76°
- (c) Lead V_{YB} by 53.14°
- (d) Lag V_{YB} by 53.14°

55. A 2-port network is represented by the following equations :

$$\begin{aligned} V_1 &= 60 I_1 + 20 I_2 \\ V_2 &= 20 I_1 + 40 I_2 \end{aligned}$$

The $ABCD$ parameters of the above network would be

- (a) $\begin{bmatrix} 2 & \frac{1}{20} \\ 3 & 100 \end{bmatrix}$
- (b) $\begin{bmatrix} 100 & 3 \\ 2 & \frac{1}{20} \end{bmatrix}$

(c) $\begin{bmatrix} 100 & 20 \\ 6 & 3 \end{bmatrix}$

(d) $\begin{bmatrix} 3 & 100 \\ \frac{1}{20} & 2 \end{bmatrix}$

56. Two coupled coils with $L_1 = L_2 = 0.6 H$ have a coupling coefficient of $K = 0.8$.

The turns ratio $\frac{N_1}{N_2}$ is

- (a) 4
- (b) 2
- (c) 1
- (d) 0.5

57.

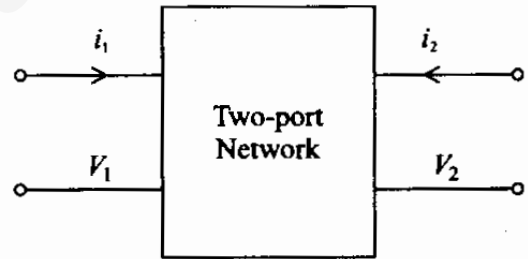

The terminal voltage and currents of a two-port network are indicated on the above figure. If the two-port is reciprocal, then

(a) $\frac{Z_{12}}{Y_{12}} = Z_{12}^2 - Z_{11} \cdot Z_{22}$

(b) $Z_{12} = \frac{1}{Y_{22}}$

(c) $h_{12} = -h_{21}$

(d) $AD - BC = 0$

58.

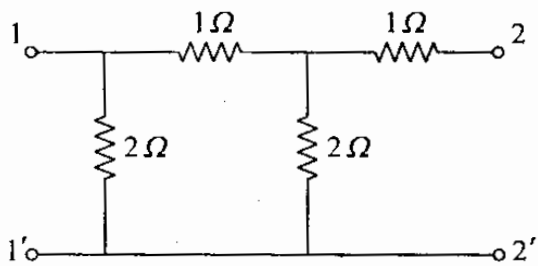

The Z-parameters of the 2-port network as shown above are

(a)
$$\begin{bmatrix} \frac{11}{5} & \frac{4}{5} \\ \frac{4}{5} & \frac{6}{5} \end{bmatrix}$$

(b)
$$\begin{bmatrix} \frac{6}{5} & \frac{4}{5} \\ \frac{4}{5} & \frac{11}{5} \end{bmatrix}$$

(c)
$$\begin{bmatrix} \frac{4}{5} & \frac{6}{5} \\ \frac{11}{5} & \frac{4}{5} \end{bmatrix}$$

(d)
$$\begin{bmatrix} \frac{4}{5} & \frac{4}{5} \\ \frac{11}{5} & \frac{6}{5} \end{bmatrix}$$

59.

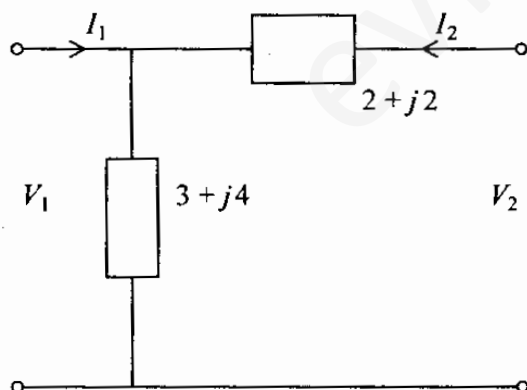

The Z-parameter matrix of the two-port network as shown above is

(a)
$$\begin{bmatrix} 3 + j4 & 2 + j2 \\ 2 + j2 & 5 + j6 \end{bmatrix}$$

(b)
$$\begin{bmatrix} 3 + j4 & 3 + j4 \\ 3 + j4 & 5 + j6 \end{bmatrix}$$

(c)
$$\begin{bmatrix} 2 + j2 & 3 + j4 \\ 2 + j2 & 5 + j6 \end{bmatrix}$$

(d)
$$\begin{bmatrix} 3 + j4 & 2 + j2 \\ 1 + j2 & 3 + j4 \end{bmatrix}$$

60. In the two-wattmeter method of measuring 3-phase power, the wattmeters indicate equal and opposite readings when load power factor is

(a) 90 leading

(b) 90 lagging

(c) 30 leading

(d) 30 lagging

61. If 3-phase power is measured with the help of two-wattmeter method in a balanced load with the application of 3-phase balanced voltage, variation in readings of wattmeters will depend on

(a) load only

(b) power factor only

(c) load and power factor

(d) neither load nor power factor

62. The driving-point impedance of an RC network is given by

$$Z(s) = \frac{(2s^2 + 7s + 3)}{(s^2 + 3s + 1)}$$

Its canonical realization will be

- (a) 6 elements
 (b) 5 elements
 (c) 4 elements
 (d) 3 elements
63. Consider the following statements :

The causes of error in the measurement of temperature using a thermistor are

1. Self heating
2. Poor sensitivity
3. Non-linear characteristics

Which of these statements are correct ?

- (a) 1, 2 and 3
 (b) 1 and 2 only
 (c) 2 and 3 only
 (d) 1 and 3 only
64. Five observers have taken a set of independent voltage measurements and recorded as 110.10 V, 110.20 V, 110.15 V, 110.30 V and 110.25 V. Under the situation mentioned above, the range of error is
- (a) ± 0.3
 (b) ± 0.1
 (c) ± 0.2
 (d) ± 1.0

65. The technique used to check quantitatively whether the given data distribution is close to Gaussian distribution is

- (a) curve fitting
 (b) method of least squares
 (c) Chi-square test
 (d) standard deviation of mean

66. The unknown resistance R_4 measured in a Wheatstone bridge by the formula

$$R_4 = \frac{(R_2 R_3)}{R_1} \text{ with}$$

$$R_1 = 100 \pm 0.5\% \Omega,$$

$$R_2 = 1000 \pm 0.5\% \Omega,$$

$$R_3 = 842 \pm 0.5\% \Omega$$

resulting in R_4

- (a) $8420 \pm 0.5\% \Omega$
 (b) $8420 \pm 1.0\% \Omega$
 (c) $8420 \pm 1.5\% \Omega$
 (d) $8420 \pm 0.125\% \Omega$
67. If one of the control springs of a permanent magnet coil ammeter is broken, then on being connected it will read
- (a) zero
 (b) half of the correct value
 (c) twice of the correct value
 (d) an infinite value

68. A 0.5Ω resistance is required to be connected in parallel to a moving coil instrument whose full scale deflection is 1 mA; so that this instrument can measure 10 mA current. Internal resistance of this instrument is

- (a) 5.0Ω
- (b) 4.5Ω
- (c) 2.25Ω
- (d) 0.45Ω

69. The working of a PMMC (Permanent magnet moving coil) meter is described by a second order differential equation

$$J \frac{d^2\theta}{dt^2} + D \frac{d\theta}{dt} + S\theta = T.$$

Where

J = Moment of inertia of the system,

D = Damping coefficient,

S = Spring constant,

θ = Angular deflection and

T = Activating torque.

Assuming $D = 0$, an undamped natural angular frequency is

- (a) $\sqrt{\frac{S}{J}}$
- (b) $\sqrt{\frac{J}{S}}$
- (c) $\frac{1}{\sqrt{JS}}$
- (d) $\frac{1}{2\mu\sqrt{JS}}$

70. For a certain dynamometer ammeter the mutual inductance (M) varies with deflection θ° as $M = -6 \cos(\theta + 30^\circ) \text{ mH}$. Find the deflecting torque produced by a direct current of 50 mA corresponding to a deflection of 60° .

- (a) 10 N-m
- (b) 20 N-m
- (c) $15 \mu\text{N-m}$
- (d) $1.5 \mu\text{N-m}$

71. An 1-m Amp, 50Ω Galvanometer is required to measure 5 Amp (full scale). Find out the value of resistance to be added, across (shunt) the Galvanometer to accomplish this measurement.

- (a) 10Ω
- (b) 0.01Ω
- (c) 1.0Ω
- (d) 0.001Ω

72. The voltage sensitivities of Barium Titanate and Quartz are respectively $12 \times 10^{-3} \text{ Vm/N}$ and $50 \times 10^{-3} \text{ Vm/N}$. Their respective permittivities are $12.5 \times 10^{-9} \text{ F/m}$ and $40.6 \times 10^{-12} \text{ F/m}$. What are their charge sensitivities?

- (a) $1.04 \times 10^6 \text{ C/N}$ and $1.23 \times 10^9 \text{ C/N}$
- (b) 150 pC/N and 2 pC/N
- (c) 24.5 pC/N and 90.6 pC/N
- (d) $0.9 \times 10^6 \text{ C/N}$ and $1.23 \times 10^9 \text{ C/N}$

73. In two-wattmeter method of measuring power in a balanced 3-phase circuit, the readings of the two wattmeters are in the ratio of 1 : 2, the circuit power factor is

- (a) $\frac{1}{\sqrt{2}}$
- (b) $\frac{1}{2}$
- (c) $\frac{\sqrt{3}}{2}$
- (d) 1

74. Consider the following statements :

Adjustment is required in an induction type energy meter in the following manner so that it can be compensated for slowdown of speed on the specified load due to some unspecified reason :

1. Adjusting the position of braking magnet and moving it away from the centre of the disc.
2. Adjusting the position of braking magnet and moving it closer to the centre of the disc.
3. Adjusting the load.

Which of these statements are correct ?

- (a) 1, 2 and 3
- (b) 1 only
- (c) 2 only
- (d) 3 only

75. Volt-box is basically a device used for

- (a) measuring the voltage
- (b) extending the range of voltmeter
- (c) extending the voltage range of the potentiometer
- (d) measuring power

76. To minimize voltmeter loading

- (a) voltmeter operating current has to be very small
- (b) voltmeter operating current has to be very high
- (c) resistance connected in series with the coil should be low
- (d) resistance connected in parallel with the coil should be high

77. A 3-phase moving coil type power factor meter has three fixed and symmetrically spaced current coils, inside of which are three other similarly placed moving potential coils. While in operation, rotating magnetic field is produced

- (a) in the current coils but not in the potential coils
- (b) in the potential coils but not in the current coils
- (c) in both potential coils and the current coils
- (d) in neither the potential coils nor the current coils

78. In a low power factor wattmeter, sometimes compensating coil is connected in order to

- (a) neutralize the capacitive effect of pressure coil
- (b) compensate for inductance of pressure coil
- (c) compensate for power loss in the pressure coil
- (d) reduce the error caused by eddy current

79. The current and potential coils of a wattmeter were accidentally interchanged while connecting. After energizing the circuit, it was observed that the wattmeter did not show the reading. This would be due to

- (a) damage done to the potential coil
- (b) damage done to the current coil
- (c) damage done to both potential and current coils
- (d) loose contact

80. A current $i = 5 + 14.14 \sin(314t + 45^\circ)$ is passed through a centre-zero PMMC, hot-wire, and moving-iron instrument, the respective readings are
- $-5, 15$ and $\sqrt{125}$
 - $5, \sqrt{125}$ and $\sqrt{125}$
 - $-5, \sqrt{125}$ and 19.14
 - $5, 10$ and 10
81. The galvanometer is protected during transport by
- connecting critical damping-resistance across the galvanometer terminals
 - shorting the galvanometer terminals
 - keeping the galvanometer terminals open-circuited
 - connecting a capacitor across the galvanometer terminals
82. A frequency counter needs to measure a frequency of 15 Hz . Its signal gating time is 2 s . What is the percentage accuracy of the counter, taking into account the gating error?
- 3.33%
 - 13.33%
 - 98.67%
 - 96.67%
83. Wagner's earthing device is used in A.C. bridges for
- shielding the bridge elements
 - eliminating the stray electrostatic field effects
 - eliminating the effect of earth capacitance
 - eliminating the effect of inter-component capacitances
84. A bridge circuit works at a frequency of 2 kHz . The following can be used as detectors for detection of null conditions in the bridge
- Vibration galvanometers and Headphones
 - Headphones and Tunable amplifiers
 - Vibration galvanometers and Tunable amplifiers
 - Vibration galvanometers, Headphones and Tunable amplifiers
85. A current transformer has a phase error of $+3^\circ$. The phase angle between the primary and secondary currents is
- 3°
 - 177°
 - 180°
 - 183°
86. Electronic voltmeters which use rectifiers employ negative feedback. This is done
- to increase the overall gain
 - to improve the stability
 - to overcome the non-linearity of diodes
 - to increase the bandwidth
87. Creep error may occur in induction type energy meter due to
- incorrect position of brake magnet
 - incorrect adjustment of position of shading band
 - overvoltage across voltage coil
 - increase in temperature

88. An 8-bit successive approximation DVM of 5 V range is used to measure 1.2 V. The contents of the SAR after 5 clock pulses is
- 01010000
 - 00111100
 - 00111000
 - 00110111
89. In a digital voltmeter, the oscillator frequency is 400 kHz. A ramp voltage to be measured by this voltmeter falls from 8 V to 0 V in 20 ms. The number of pulses counted by the counter is
- 8000
 - 4000
 - 3200
 - 1600
90. While using a frequency counter for measuring frequency, two modes of measurement are possible. (i) Period mode (ii) Frequency mode. There is a 'cross-over frequency' below which the period mode is preferred. Assuming the crystal oscillator frequency to be 4 MHz the cross-over frequency is given by
- 8 MHz
 - 2 MHz
 - 2 kHz
 - 1 kHz
91. Which of the following instrument will be used to measure a small current of very high frequency ?
- Electrodynamometer
 - Moving coil galvanometer
 - Thermocouple type instrument
 - Induction type instrument
92. In a digital data acquisition system, a scanner-multiplexer
- scans the printed diagram and converts it into digital data
 - accepts multiple digital inputs and output any one of them with select lines
 - accepts multiple analog inputs and sequentially connects them to an ADC
 - checks the correct functioning of the modules one by one
93. The number of bits of A/D converter required to convert an analog input in the range of 0-5 volt to an accuracy of 10 mV is
- 8
 - 9
 - 10
 - 16
94. A second order system is described by
- $$2 \frac{d^2 y}{dt^2} + 4 \frac{dy}{dt} + 8y = 8x$$
- The damping ratio of the system is
- 0.1
 - 0.25
 - 0.333
 - 0.5
95. When deriving the transfer function of a linear element
- both initial conditions and loading are taken into account
 - initial conditions are taken into account but the element is assumed to be not loaded
 - initial conditions are assumed to be zero but loading is taken into account
 - initial conditions are assumed to be zero and the element is assumed to be not loaded

96. Consider the following statements regarding advantages of closed loop negative feedback control systems over open loop systems :

1. The overall reliability of the closed loop system is more than that of open loop system.
2. The transient response in a closed loop system decays more quickly than in open loop system.
3. In an open loop system, closing of the loop increases the overall gain of the system.
4. In the closed loop system, the effect of variation of component parameters on its performance is reduced.

Which of these statements are correct ?

- (a) 1 and 2
- (b) 1 and 3
- (c) 2 and 4
- (d) 3 and 4

97. A forcing function $(t^2 - 2t)u(t - 1)$ is applied to a linear system. The \mathcal{L} -transform of the forcing function is

- (a) $\frac{2-s}{s^3} \epsilon^{-2s}$
- (b) $\left(\frac{1-s^2}{s}\right) \epsilon^{-s}$
- (c) $\frac{1}{s} e^{-s} - \frac{1}{s^2} \epsilon^{-2s}$
- (d) $\left(\frac{2-s^2}{s^3}\right) \epsilon^{-s}$

98. An open loop TF of a unity feedback system is given by

$$G(s) = \frac{1}{(s+2)^2}$$

The closed loop transfer function will have poles at

- (a) -2, -2
- (b) -2, -1
- (c) -2+j, -2-j
- (d) -2, 2

99. Damping ratio ξ and peak overshoot M_p are measures of

- (a) relative stability
- (b) absolute stability
- (c) speed of response
- (d) steady state error

100. In control systems, excessive bandwidth is *not* employed because

- (a) noise is proportional to bandwidth
- (b) it leads to low relative stability
- (c) it leads to slower time response
- (d) noise is proportional to the square of the bandwidth

101. The transfer function of a system is

$\frac{1}{1+sT}$. The input to this system is the ramp function, $tu(t)$. The output would track this system with an error given by

- (a) zero
- (b) $\frac{T}{2}$
- (c) T
- (d) $\frac{T^2}{2}$

102. For a critically damped second order system, if gain constant (K) is increased, the system behaviour

- (a) becomes oscillatory
- (b) becomes under damped
- (c) becomes over damped
- (d) shows no change

103. A unit impulse response of a second order system is $\frac{1}{6}e^{-0.8t}\sin(0.6t)$. Then natural frequency and damping ratio of the system are respectively

- (a) 1 and 0.6
- (b) 1 and 0.8
- (c) 2 and 0.4
- (d) 2 and 0.3

104. Consider the following statements about Routh-Hurwitz criterion :

If all the elements in one row of Routh array are zero, then there are

1. Pairs of conjugate roots on imaginary axis.
2. Pairs of equal roots with opposite sign.
3. Conjugate roots forming a quadrate in the s -plane.

Which of these statements are correct ?

- (a) 1 and 2 only
- (b) 1 and 3 only
- (c) 2 and 3 only
- (d) 1, 2 and 3

105. The characteristic equation of a control system is given by

$$s(s + 4)(s + 5)(s + 6) + K(s + 3) = 0$$

The number of asymptotes and the centroid of the asymptotes of this control system are

- (a) 3 and (4, 0)
- (b) -3 and (-4, 0)
- (c) -3 and (-12, 0)
- (d) 3 and (-4, 0)

106. An effect of phase-lag compensation on servo-system performance is that

- (a) for a given relative stability, the velocity constant is increased
- (b) for a given relative stability, the velocity constant is decreased
- (c) the bandwidth of the system is increased
- (d) the time response of the system is made faster

107. The system matrix of a linear time invariant continuous time system is

given by $A = \begin{bmatrix} 0 & 1 \\ -4 & -5 \end{bmatrix}$

What are the roots of the characteristic equation ?

- (a) -1, -4
- (b) -1, -5
- (c) -4, -5
- (d) 0, -1

108. In a closed loop system for which the output is the speed of a motor, the output rate control can be used to

- (a) reduce the damping of the system
- (b) limit the torque output of the motor
- (c) limit the speed of the motor
- (d) limit the acceleration of the motor

109. A transfer function has its zero in the right half of the s -plane. The function

- (a) is positive real
- (b) is minimum phase
- (c) will give stable impulse response
- (d) is non-minimum phase

110. If the s -plane contour encloses 3-zeros and 2-poles of $q(s)$, the corresponding $q(s)$ plane contour will encircle the origin of $q(s)$ plane

- (a) Once in clockwise direction
- (b) Once in counter clockwise direction
- (c) Thrice in clockwise direction
- (d) Twice in counter clockwise direction

Directions :

Each of the next Ten (10) items consists of two statements, one labelled as the 'Statement (I)' and the other as 'Statement (II)'. You are to examine these two statements carefully and select the answers to these items using the codes given below :

Codes :

- (a) Both Statement (I) and Statement (II) are individually true and Statement (II) is the correct explanation of Statement (I)
- (b) Both Statement (I) and Statement (II) are individually true but Statement (II) is **NOT** the correct explanation of Statement (I)
- (c) Statement (I) is true but Statement (II) is false
- (d) Statement (I) is false but Statement (II) is true

111. Statement (I) : The Dielectric constant of a substance, under the influence of alternating electric fields is, in general, a 'complex' quantity.

Statement (II) : The 'imaginary' part of the Dielectric constant is a measure of the dielectric loss in the substance.

112. Statement (I) : A large number of metals become superconducting below a certain temperature which is characteristic of the particular metal.

Statement (II) : Superconducting compounds and alloys must have components which are themselves superconducting.

113. Statement (I) : Electrostriction occurs due to piezoelectricity which in the reverse effect i.e. the production of polarization on application of mechanical stress if the lattice has no centre of symmetry.

Statement (II) : When an electric field is applied to a substance it becomes polarized, the electrons and nuclei assume new geometric positions and the mechanical dimensions of the substance are altered.

114. Statement (I) : By measuring the Hall-effect voltage, one can determine :

(a) The strength of the field in terms of the current, or

(b) The current in terms of the field

Statement (II) : In the case of a semiconductor, the mobility of the carriers can be determined by using (b), so long as only one kind of carrier is present.

115. Statement (I) : In an ac dynamometer-type wattmeter the instantaneous value of developed deflecting torque is proportional to the product of voltage and current in the respective coils at the corresponding instant, the constant of proportionality being the same as in the case of dc use.

Statement (II) : The moving system of the meter is prevented by its Inertia from following the variations in the deflecting torque which takes place during each cycle, and takes up a position corresponding to the average value of the torque.

116. Statement (I) : Electrostatic Wattmeter is not widely used commercially because of its inability to measure power of high value.

Statement (II) : It is used mainly for very small power measurement at high voltages and low power factors.

117. Statement (I) : Chopper-stabilized amplifier amplifies direct currents with large gain and excellent dc stability.

Statement (II) : The amplifier is ac coupled and provides very high resistance to direct current.

118. Statement (I) : Force and pressure can be measured by using capacitive transducer.

Statement (II) : Capacitive transducer can be used to measure both static and dynamic phenomena.

119. Statement (I) : A Watt-hour meter must be calibrated at both full rated load as well as at 10% of rated load.

Statement (II) : The source of error at full load is inaccurate damping and at light loads, the torque is not exactly proportional to load.

120. Statement (I) : For random error with Normal distribution, probable error = $\pm 0.6745 \sigma$, where σ is the standard deviation.

Statement (II) : Probable error ξ_p is that error value where there is a 50% chance that any observation has a random error no greater than $\pm \xi_p$.

SPACE FOR ROUGH WORK

evidyarthi.in

SPACE FOR ROUGH WORK

evidyarthi.in

SPACE FOR ROUGH WORK

evidyarthi.in