

DO NOT OPEN THIS TEST BOOKLET UNTIL YOU ARE ASKED TO DO SO

T.B.C. : B-DMHH-N-DFA

Test Booklet Series

Serial No. 43869



**TEST BOOKLET
CIVIL ENGINEERING**

Paper—I

Time Allowed : Two Hours

Maximum Marks : 200

INSTRUCTIONS

1. IMMEDIATELY AFTER THE COMMENCEMENT OF THE EXAMINATION, YOU SHOULD CHECK THAT THIS TEST BOOKLET *DOES NOT* HAVE ANY UNPRINTED OR TORN OR MISSING PAGES OR ITEMS, ETC. IF SO, GET IT REPLACED BY A COMPLETE TEST BOOKLET.
2. Please note that it is the candidate's responsibility to encode and fill in the Roll Number and Test Booklet Series Code A, B, C or D carefully and without any omission or discrepancy at the appropriate places in the OMR Answer Sheet. Any omission/ discrepancy will render the Answer Sheet liable for rejection.
3. You have to enter your Roll Number on the Test Booklet in the Box provided alongside. *DO NOT* write *anything else* on the Test Booklet.
4. This Test Booklet contains 120 items (questions). Each item comprises four responses (answers). You will select the response which you want to mark on the Answer Sheet. In case you feel that there is more than one correct response, mark the response which you consider the best. In any case, choose *ONLY ONE* response for each item.
5. You have to mark your responses *ONLY* on the separate Answer Sheet provided. See directions in the Answer Sheet.
6. All items carry equal marks.
7. Before you proceed to mark in the Answer Sheet the response to various items in the Test Booklet, you have to fill in some particulars in the Answer Sheet as per instructions sent to you with your Admission Certificate.
8. After you have completed filling in all your responses on the Answer Sheet and the examination has concluded, you should hand over to the Invigilator *only the Answer Sheet*. You are permitted to take away with you the Test Booklet.
9. Sheets for rough work are appended in the Test Booklet at the end.
10. **Penalty for wrong answers :**
THERE WILL BE PENALTY FOR WRONG ANSWERS MARKED BY A CANDIDATE.
 - (i) There are four alternatives for the answer to every question. For each question for which a wrong answer has been given by the candidate, **one-third** of the marks assigned to that question will be deducted as penalty.
 - (ii) If a candidate gives more than one answer, it will be treated as **wrong answer** even if one of the given answers happens to be correct and there will be same penalty as above to that question.
 - (iii) If a question is left blank, i.e., no answer is given by the candidate, there will be **no penalty** for that question.

DO NOT OPEN THIS TEST BOOKLET UNTIL YOU ARE ASKED TO DO SO

1. Which IS code is used for classification of timber for seasoning purposes?

- (a) IS : 4970-1973
- (b) IS : 1708-1969
- (c) IS : 1141-1958
- (d) IS : 399-1963

2. Consider the following with regard to 'the application of preservation of timber' :

- 1. Increase in the life span of the member
- 2. Increase in the strength of the timber
- 3. Removal of moisture
- 4. Prevention of growth of fungi by killing them

Which of the above are correct?

- (a) 1, 2, 3 and 4
- (b) 2 and 4 only
- (c) 1 and 4 only
- (d) 2 and 3 only

3. The plies in plywood are so placed that the grains of each ply are

- (a) parallel to each other
- (b) at right angle to one another
- (c) 45° oblique to adjacent grain
- (d) not constrained by any consideration

4. Which of the following is an ODD one as regards 'requirements of good brick-earth'?

- (a) It must be free from lumps of lime
- (b) It should not be mixed with salty water
- (c) It must be non-homogeneous
- (d) It should not contain vegetable and organic matter

5. The compressive strength of heavy-duty bricks, as per IS : 2980-1962, should be not less than

- (a) 440 kg/cm²
- (b) 175 kg/cm²
- (c) 100 kg/cm²
- (d) 75 kg/cm²

6. Consider the following statements :

- 1. Brickwork will have high water tightness.
- 2. Brickwork is preferred for monument structures.
- 3. Bricks resist fire better than stones.
- 4. Bricks of good quality shall have thin mortar bonds.

Which of the above statements are correct?

- (a) 1 and 2
- (b) 3 and 4
- (c) 2 and 3
- (d) 1 and 4

7. Consider the following statements :

A good soil for making bricks should contain

1. 30% alumina
2. 10% lime nodules
3. only small quantity of iron oxides
4. 15% magnesia

Which of the above statements are correct?

- (a) 1 and 2 only
- (b) 1 and 3
- (c) 1, 2 and 4
- (d) 2, 3 and 4

8. Which compound of cement is responsible for strength of cement?

- (a) Magnesium oxide
- (b) Silica
- (c) Alumina
- (d) Calcium sulphate

9. Which type of cement is recommended in large mass concrete works such as a dam?

- (a) Ordinary Portland
- (b) High Alumina
- (c) Low-heat Portland
- (d) Portland Pozzollona

10. Consider the following statements regarding 'setting of cement' :

1. Low-heat cement sets faster than OPC.
2. Final setting time decides the strength of cement.

3. Initial setting time of Portland Pozzollona is 30 minutes.

4. Air-induced setting is observed when stored under damp conditions.

5. Addition of gypsum retards the setting time.

Which of the above statements are correct?

- (a) 1, 2 and 3
- (b) 2, 3 and 4
- (c) 3, 4 and 5
- (d) 2, 3 and 5

11. Consider the following statements regarding 'strength of cement' :

1. Strength test on cement is made on cubes of cement-sand mix.

2. Water to be used for the paste is $0.25P$, where P is the water needed for normal consistency.

3. The normal consistency is determined on Le Chatelier's apparatus.

4. Cubes are cast in two layers in leak-proof moulds further compacted in each layer by vibration on a machine.

Which of the above statements are correct?

- (a) 1 and 2
- (b) 2 and 3
- (c) 1 and 4
- (d) 3 and 4

12. Which of the following ingredients refer to binding materials of mortar?

1. Cement
2. Lime
3. Sand
4. Ashes

Select the correct answer using the code given below.

- (a) 1 and 4
(b) 3 and 4
(c) 1 and 2
(d) 2 and 3

13. Consider the following statements :

1. Bricks in masonry are bound by mortar.
2. Mortars make bricks damp-proof.
3. Strength of brick in masonry is improved by plastering.
4. Addition of lime improves workability.
5. Marine constructions need sulphate-resistant cement mortar.

Which of the above statements are relevant for 'cement mortar'?

- (a) 1, 2 and 3
(b) 2, 3 and 4
(c) 1, 4 and 5
(d) 3, 4 and 5

14. Consider the following parameters of concrete :

1. Impermeability
2. Compactness
3. Durability
4. Desired consistency
5. Workability

Which of the above parameters are relevant for 'water-cement ratio'?

- (a) 4 and 5
(b) 1 and 2
(c) 2 and 4
(d) 3 and 5

15. Consider the following statements :

Presence of Na_2O and K_2O in concrete leads to

1. expansive reaction in concrete
2. cracking of concrete
3. disruption of concrete
4. shrinkage of concrete

Which of the above statements are correct?

- (a) 1 and 2 only
(b) 2 and 3 only
(c) 1, 2 and 3
(d) 3 and 4

16. The maximum total quantity of dry aggregate by mass per 50 kg of cement, to be taken as the sum of the individual masses of fine and coarse aggregates (kg), for M 20 grade of concrete, is

- (a) 625
- (b) 480
- (c) 330
- (d) 250

17. If aggregate size of 50–40 mm is to be tested for determining the proportion of elongated aggregates, the slot length of the gauge should be

- (a) 45 mm
- (b) 53 mm
- (c) 81 mm
- (d) 90 mm

18. Absorption capacity of an aggregate refers to the difference expressed in appropriate proportion in water content between

- (a) a wet aggregate and a dry aggregate
- (b) a dry aggregate and an oven-dry aggregate
- (c) a saturated surface-dry aggregate and a dry aggregate
- (d) a saturated surface-dry aggregate and an oven-dry aggregate

19. Consider the following statements concerning 'elasticity of concrete' :

- 1. Stress-strain behaviour of concrete is a straight line up to 10% of ultimate stress.
- 2. Strain determination is obtained from tangent modulus.
- 3. Modulus of elasticity of concrete is also called as secant modulus.

Which of the above statements are correct?

- (a) 1, 2 and 3
- (b) 1 and 3 only
- (c) 1 and 2 only
- (d) 2 and 3 only

20. Consider the following statements :

The addition of CaCl_2 in concrete results in

- 1. increased shrinkage
- 2. decreased setting time
- 3. decreased shrinkage
- 4. increased setting time

Which of the above statements is/ are correct?

- (a) 1 only
- (b) 2 and 3
- (c) 3 and 4
- (d) 1 and 2

21. If the Poisson's ratio for a material is 0.5, then the elastic modulus for the material is

- (a) three times its shear modulus
- (b) four times its shear modulus
- (c) equal to its shear modulus
- (d) not determinable

22. A metal bar of 10 mm diameter when subjected to a pull of 23.5 kN gave an elongation of 0.3 mm on a gauge length of 200 mm. The Young's modulus of elasticity of the metal will nearly be

- (a) 200 kN/mm²
- (b) 300 kN/mm²
- (c) 360 kN/mm²
- (d) 400 kN/mm²

23. A steel rod, 2 m in length, 40 mm in diameter, is subjected to a pull of 70 kN as shown in the figure

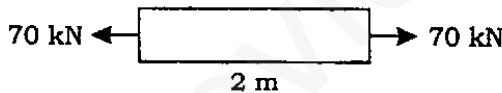

To what length should the bar be bored centrally from one end so that total extension will increase by 20% under the same force (the bore diameter is 25 mm and E is $2 \times 10^5 \text{ N/mm}^2$)?

- (a) 0.46 m
- (b) 0.55 m
- (c) 0.87 m
- (d) 0.62 m

24. A member ABCD is subjected to a force system as shown in the figure

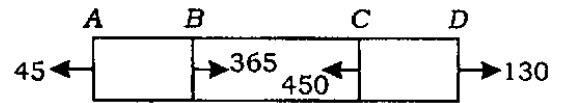

The resistive force in the part BC is

- (a) 365 (compressive)
- (b) 450 (tensile)
- (c) 85 (compressive)
- (d) 320 (compressive)

25. Consider the following statements :

If the planes at right angles carry only shear stress of magnitude q in a certain instance, then the

1. diameter of Mohr's circle would be equal to $2q$
2. centre of Mohr's circle would lie at the origin
3. principal stresses are unlike and are of magnitude q each
4. angle between the principal plane and the plane of maximum shear would be 45°

Which of the above statements are correct?

- (a) 1, 2 and 3 only
- (b) 1, 2 and 4 only
- (c) 3 and 4 only
- (d) 1, 2, 3 and 4

26. The state of two-dimensional stresses acting on a concrete lamina consists of a direct tensile stress $\sigma_x = 1.5 \text{ N/mm}^2$ and shear stress $\tau = 1.20 \text{ N/mm}^2$, when cracking of concrete is just impending. The permissible tensile strength of the concrete is

- (a) 1.50 N/mm^2
- (b) 2.17 N/mm^2
- (c) 2.08 N/mm^2
- (d) 2.29 N/mm^2

27. Two-dimensional stress system on a block made of a material with Poisson's ratio of 0.3 is shown in the figure

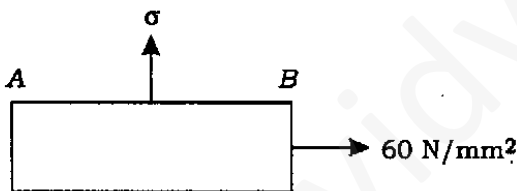

The limiting magnitude of the stress σ so as to result in no change in length AB of the block is

- (a) 60 N/mm^2
- (b) 120 N/mm^2
- (c) 200 N/mm^2
- (d) 240 N/mm^2

28. The principal stresses at a point in a bar are 160 N/mm^2 (tensile) and 80 N/mm^2 (compressive). The accompanying maximum shear stress intensity is

- (a) 100 N/mm^2
- (b) 110 N/mm^2
- (c) 120 N/mm^2
- (d) 140 N/mm^2

29. An element of a certain material in plane strain has

$$\epsilon_x = 800 \times 10^{-6}$$

$$\epsilon_y = 400 \times 10^{-6}$$

$$\gamma_{xy} = 300 \times 10^{-6}$$

What is the maximum shearing strain?

- (a) 150×10^{-6}
- (b) 355×10^{-6}
- (c) 250×10^{-6}
- (d) 500×10^{-6}

30. Consider a circular member of diameter D subjected to a compressive load P . For a condition of no tensile stress in the cross-section, the maximum radial distance of the load from the centre of the circle is

(a) $\frac{D}{6}$

(b) $\frac{D}{8}$

(c) $\frac{D}{12}$

(d) $\frac{D}{4}$

31. At a point in the web of a girder, the bending and the shearing stresses are 90 N/mm^2 (tensile) and 45 N/mm^2 respectively. The principal stresses are

(a) 108.64 N/mm^2 (tensile) and 18.64 N/mm^2 (compressive)

(b) 107.60 N/mm^2 (compressive) and 18.64 N/mm^2 (tensile)

(c) 108.64 N/mm^2 (compressive) and 18.64 N/mm^2 (tensile)

(d) 0.64 N/mm^2 (tensile) and 0.78 N/mm^2 (compressive)

32. In a two-dimensional stress system, the principal stresses are $\sigma_1 = 200 \text{ N/mm}^2$ (tensile) and σ_2 (compressive). The yield stress in both simple tension and compression is 250 N/mm^2 , with $\mu = 0.25$. What will be the value of σ_2 according to the maximum normal strain theory?

(a) 160 N/mm^2

(b) 100 N/mm^2

(c) 200 N/mm^2

(d) 250 N/mm^2

33. A simply supported beam has uniform cross-section, $b = 100 \text{ mm}$, $d = 200 \text{ mm}$, throughout its length. The beam is subjected to a maximum bending moment of $6 \times 10^7 \text{ N-mm}$. The corresponding bending stress developed in the beam is

(a) 30 N/mm^2

(b) 60 N/mm^2

(c) 90 N/mm^2

(d) 120 N/mm^2

34. A steel plate is bent into a circular arc of radius 10 m. If the plate section be 120 mm wide and 20 mm thick, with $E = 2 \times 10^5 \text{ N/mm}^2$, then the maximum bending stress induced is

- (a) 210 N/mm^2
- (b) 205 N/mm^2
- (c) 200 N/mm^2
- (d) 195 N/mm^2

35. A fletched beam composed of two different pieces, each having breadth b and depth d , supports an external load. This statement implies that

1. the two different materials are rigidly connected
2. there will be relative movement between the two materials
3. for transforming into an equivalent single-material section under 'strength' considerations, the depth is kept constant and only the breadth is varied

Which of the above statements are correct?

- (a) 1 and 2 only
- (b) 1 and 3 only
- (c) 2 and 3 only
- (d) 1, 2 and 3

36. A solid shaft of 80 mm diameter is transmitting 100 kW of power at 200 r.p.m. The maximum shear stress induced in the shaft will nearly be

- (a) 60 N/mm^2
- (b) 56 N/mm^2
- (c) 52 N/mm^2
- (d) 48 N/mm^2

37. The power transmitted by a 75 mm diameter shaft at 140 r.p.m., subjected to a maximum shear stress of 60 N/mm^2 , is nearly

- (a) 68 kW
- (b) 70 kW
- (c) 73 kW
- (d) 76 kW

38. A circular shaft of diameter D is subjected to a torque T . The maximum shear stress of the shaft will be

- (a) proportional to D^3
- (b) proportional to D^4
- (c) inversely proportional to D^3
- (d) inversely proportional to D^4

39. A hollow shaft of 16 mm outside diameter and 12 mm inside diameter is subjected to a torque of 40 N-m. The shear stresses at the outside and inside of the material of the shaft are respectively

- (a) 62.75 N/mm² and 50.00 N/mm²
- (b) 72.75 N/mm² and 54.54 N/mm²
- (c) 79.75 N/mm² and 59.54 N/mm²
- (d) 80.00 N/mm² and 40.00 N/mm²

40. A rigid bar shown in the figure is hinged at A, is supported by a rod at B, and carries a load W at C.

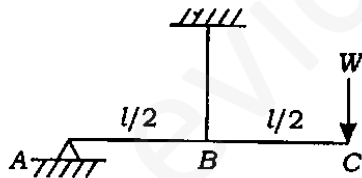

The resistive force in the rod is

- (a) 0.5W
- (b) 1.0W
- (c) 1.5W
- (d) 2.0W

41. The symmetry of the stress tensor at a point in a body when at equilibrium is obtained from

- (a) conservation of mass
- (b) force equilibrium equations
- (c) moment equilibrium equations
- (d) conservation of energy

42. A hinged support in a real beam

- (a) becomes an internal hinge in a conjugate beam
- (b) changes to a free support in a conjugate beam
- (c) changes to a fixed support in a conjugate beam
- (d) remains as a hinged support in a conjugate beam

43. For portal frame shown in the figure, collapse load W has been calculated as per combined mechanism as

$$W = \frac{16 M_p}{3l}$$

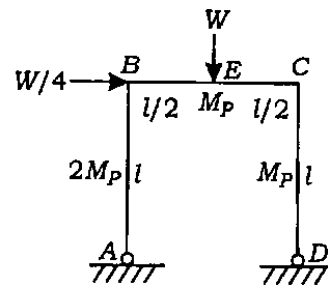

What is the bending moment at B at collapse conditions?

- (a) $\frac{Wl}{16}$
- (b) $\frac{Wl}{8}$
- (c) $\frac{3Wl}{16}$
- (d) $\frac{3Wl}{8}$

44. The simply supported beam shown in the figure

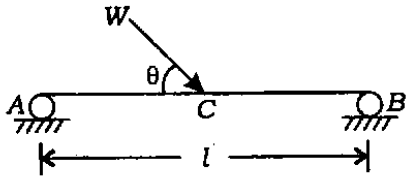

is

- (a) determinate and stable
- (b) determinate and unstable
- (c) indeterminate and stable
- (d) indeterminate and unstable

45. The bending moment at C for the beam shown in the figure

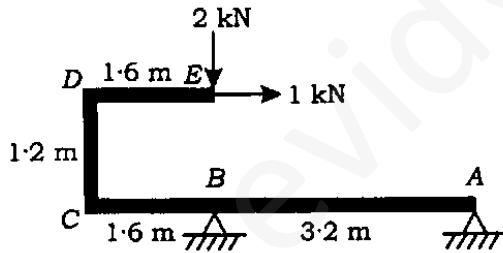

is

- (a) -3.2 kN-m
- (b) -4.4 kN-m
- (c) -6.2 kN-m
- (d) -7.2 kN-m

46. A close helical spring of 100 mm mean diameter is made of 10 mm diameter rod, and has 20 turns. The spring carries an axial load of 200 kN with $G = 84 \times 10^4 \text{ N/mm}^2$. The stiffness of the spring is nearly

- (a) 5.25 N/mm
- (b) 6.50 N/mm
- (c) 7.25 N/mm
- (d) 8.50 N/mm

47. For the plane frame as shown in the figure

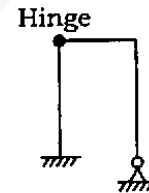

the degree of kinematic indeterminacy, neglecting axial deformation, is

- (a) 3
- (b) 5
- (c) 7
- (d) 9

48. The carry-over factor C_{AB} for the beam as shown in the figure

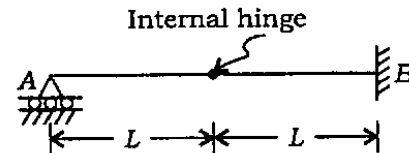

is

- (a) 0.25
- (b) 0.50
- (c) 0.75
- (d) 1.00

49. The ratio of (i) the moment required for unit rotation of the near end of a prismatic member with its far end fixed to (ii) that of a different moment required for the same effect when the far end is hinged, is

(a) 1 (b) $\frac{3}{4}$

(c) $\frac{4}{3}$ (d) $\frac{1}{2}$

50. Force method in structural analysis always ensures

- (a) compatibility of deformation
- (b) equilibrium of forces
- (c) kinematically admissible strains
- (d) overall safety

51. Fixed end moments at A and B for the fixed beam shown in the figure, subjected to the indicated uniformly varying load, are respectively

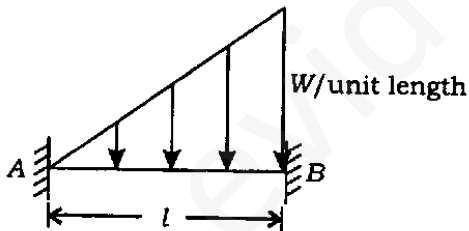

(a) $\frac{Wl^2}{30}$ and $\frac{Wl^2}{20}$

(b) $\frac{Wl^2}{20}$ and $\frac{Wl^2}{30}$

(c) $\frac{Wl^2}{12}$ and $\frac{Wl^2}{8}$

(d) $\frac{Wl^2}{8}$ and $\frac{Wl^2}{12}$

52. Fixed end moments developed at both the ends in a fixed beam of span L and flexural rigidity EI , when its right-side support settles down by Δ , is

(a) $\frac{6EI\Delta}{L^2}$ (sagging)

(b) $\frac{12EI\Delta}{L^2}$ (sagging)

(c) $\frac{6EI\Delta}{L^2}$ (hogging)

(d) $\frac{12EI\Delta}{L^2}$ (hogging)

53. The Muller-Breslau principle for influence line is applicable for

- (a) simple beams
- (b) continuous beams
- (c) redundant trusses
- (d) All of the above

54. For a fixed beam with a concentrated load W at $\frac{1}{4}$ of span from one end, the ultimate load is

(a) $\frac{16M_P}{3L}$ (b) $\frac{4M_P}{L}$

(c) $\frac{32M_P}{3L}$ (d) $\frac{6M_P}{L}$

[adopting standard notations]

55. The plastic modulus of a section is $4.8 \times 10^{-4} \text{ m}^3$. The shape factor is 1.2. The plastic moment capacity of the section is 120 kN-m. The yield stress of the material is

- (a) 100 MPa
- (b) 240 MPa
- (c) 250 MPa
- (d) 300 MPa

56. A propped cantilever beam shown in the figure has a plastic moment capacity of M_0 .

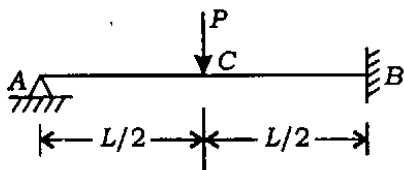

The collapse load is

- (a) $\frac{4M_0}{L}$
- (b) $\frac{6M_0}{L}$
- (c) $\frac{8M_0}{L}$
- (d) $\frac{12M_0}{L}$

57. The dimensions of a T-section are shown in the figure

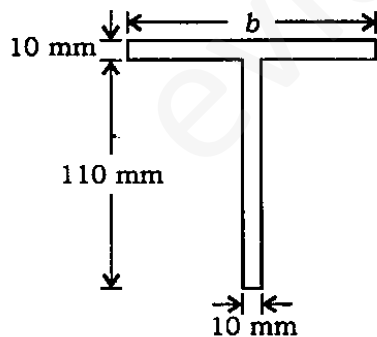

For the depth of plastic neutral axis from the top of the T-section to be 9.583 mm, the flange width b must be

- (a) 100 mm
- (b) 110 mm
- (c) 120 mm
- (d) 130 mm

58. The shape factors of a triangle section and a diamond section are respectively

- (a) 2.343 and 2.0
- (b) 2.0 and 2.343
- (c) 1.343 and 2.0
- (d) 2.0 and 1.343

59. For a skeletal frame shown in the figure

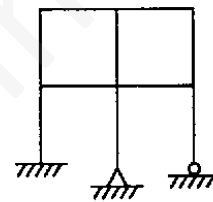

static and kinematic indeterminacies are

- (a) 3 and 11
- (b) 3 and 9
- (c) 3 and 6
- (d) 6 and 3

60. The effective length of a fillet weld is taken as the actual length

- (a) plus twice the size of the weld
- (b) minus twice the size of the weld
- (c) plus the size of the weld
- (d) minus the size of the weld

61. An angle ISA $50 \times 50 \times 6$ is connected to a gusset plate 5 mm thick, with 16 mm bolts. What is the bearing strength of the bolt when the hole diameter is 16 mm and the allowable bearing stress is 250 MPa?
- (a) 8 kN
(b) 20 kN
(c) 22.5 kN
(d) 24 kN
62. The effective length of a battened strut of actual length L , effectively held in position at both ends but not restrained in direction, is taken as
- (a) L (b) $1.1L$
(c) $1.5L$ (d) $1.8L$
63. The slenderness ratio (as per IS : 800) of a member, carrying compressive loads arising from combined dead loads and imposed loads, should not exceed
- (a) 180 (b) 250
(c) 350 (d) 380
64. A mild steel tube of mean diameter 20 mm and thickness 2 mm is used as an axially loaded tension member. If $f_y = 300$ MPa, what is the maximum load that the member can carry?
- (a) 11.25 kN
(b) 22.5 kN
(c) 30.0 kN
(d) 37.5 kN
65. Localized bearing stress caused by the transmission of compression from the wide flange to the narrow web causes a failure called
- (a) web buckling
(b) web shear flow
(c) web bearing
(d) web crippling
66. The best-suited rolled steel section for a tension member is
- (a) angle section
(b) T-section
(c) channel section
(d) flat section
67. In a plate girder, the web is primarily designed to resist
- (a) torsional moment
(b) shear force
(c) bending moment
(d) diagonal buckling
68. Lacing of compound steel columns
- (a) increases the load-carrying capacity
(b) decreases the chances of local buckling
(c) decreases overall buckling of the column
(d) assures unified behaviour

69. A welded plate girder, consisting of two flange plates of 350 mm × 16 mm each and a web plate of 1000 mm × 6 mm, requires

- (a) no stiffeners
- (b) horizontal stiffeners
- (c) intermediate vertical stiffeners
- (d) vertical and horizontal stiffeners

70. When designing steel structures, one must ensure that local buckling in webs does not take place. This check may not be critical when using rolled steel sections because

- (a) quality control at the time of manufacture of rolled sections is very good
- (b) web depths available are small
- (c) web stiffness is built-in in rolled sections
- (d) depth to thickness ratio of the web is always appropriately adjusted

71. Horizontal stiffener in a plate girder is provided to safeguard against web buckling due to

- (a) shear
- (b) compressive force in bending
- (c) tensile force in bending
- (d) heavy concentrated load

72. In an industrial steel building, which of the following elements of a pitched roof primarily resist loads parallel to the ridge?

- (a) Bracings
- (b) Purlins
- (c) Columns
- (d) Trusses

73. For a compression member with double angle section, which of the following sections will give larger value of minimum radius of gyration?

- (a) Equal angles back-to-back
- (b) Unequal angles with long legs back-to-back
- (c) Unequal angles with short legs back-to-back
- (d) None of the above

74. According to IS : 875 Part 3, design wind speed is obtained by multiplying the basic wind speed by factors k_1 , k_2 and k_3 , where k_3 is

- (a) terrain height factor
- (b) structure size factor
- (c) topography factor
- (d) risk coefficient

75. The length of beam over which the moment is greater than the yield moment is called as the plastic hinge length. What is the plastic hinge length for a simply supported beam of circular cross-section loaded at mid-span (shape factor for the section = $\frac{5}{3}$)?

- (a) $0.15l$
- (b) $0.33l$
- (c) $0.4l$
- (d) $0.5l$

[adopting standard notations]

76. Battens provided for a compression member shall be designed to carry a transverse shear equal to

- (a) 2.5% of axial force in the member
- (b) 5% of axial force in the member
- (c) 10% of axial force in the member
- (d) 20% of axial force in the member

77. In which of the following cases is the compression flange most susceptible to buckle laterally?

- (a) An I-section supporting a roof slab with shear connection
- (b) Purlin of a roof supporting dead and live loads
- (c) Encased beam
- (d) A steel I-section supporting a point load when acting as a cantilever

78. The serviceability criterion for a plate girder design is based upon

- (a) width of flange
- (b) depth of web
- (c) minimum thickness of web
- (d) stiffness of web

79. If any tension reinforcement in an RC beam attains its yield stress during loading before the concrete in the compression zone fails due to crushing, the beam is said to be

- (a) under-reinforced
- (b) over-reinforced
- (c) balanced
- (d) non-homogeneous

80. The distance between the centroid of the area of tension reinforcement and the maximum compressive fibre in a reinforced concrete beam design is known as

- (a) overall depth
- (b) effective depth
- (c) lever arm
- (d) depth of neutral axis

81. In a reinforced concrete section, the shape of the nominal shear stress diagram is
- (a) parabolic over the full depth
 - (b) parabolic above the neutral axis and rectangular below the neutral axis
 - (c) rectangular over the full depth
 - (d) rectangular above the neutral axis and parabolic below the neutral axis
82. Assuming the concrete below the neutral axis to be cracked, the shear stress across the depth of a singly reinforced rectangular beam section
- (a) increases parabolically to the neutral axis and then drops abruptly to zero value
 - (b) increases parabolically to the neutral axis and then remains constant over the remaining depth
 - (c) increases linearly to the neutral axis and then remains constant up to the tension steel
 - (d) increases parabolically to the neutral axis and then remains constant up to the tension steel
83. Critical section for shear in case of flat slabs is
- (a) at a distance of effective depth of slab from the periphery of the column/the drop panel
 - (b) at a distance of $\frac{d}{2}$ from the periphery of the column/the capital/the drop panel
 - (c) at the drop panel of the slab
 - (d) at the periphery of the column
- [adopting standard notations]
84. The enlarged head of the supporting column of a flat slab is called
- (a) capital
 - (b) drop
 - (c) panel
 - (d) block
85. The critical section for maximum bending moment in the footing under masonry wall is located at
- (a) the middle of the wall
 - (b) the face of the wall
 - (c) mid-way between the face and the middle of the wall
 - (d) a distance equal to the effective depth of footing from the face of the wall
86. The problems of lateral buckling can arise only in those steel beams which have
- (a) moment of inertia about the bending axis larger than the other
 - (b) moment of inertia about the bending axis smaller than the other
 - (c) fully supported compression flange
 - (d) None of the above

87. Consider the following statements :

The design depth of the footing for an isolated column is governed by

1. maximum bending moment
2. maximum shear force
3. punching shear

Which of the above statements are correct?

- (a) 1 and 2 only
- (b) 1 and 3 only
- (c) 1, 2 and 3
- (d) 2 and 3 only

88. Spalling stresses are produced in post-tensioned pre-stressed concrete members at

- (a) locations of maximum bending moment only
- (b) locations of maximum shear zone
- (c) anchorage zone
- (d) bond-developing zone

89. In a pre-stressed member, it is advisable to use

- (a) low-strength concrete
- (b) high-strength concrete
- (c) high-strength concrete and high-tension steel
- (d) high-strength concrete and low-tension steel

90. The percentage loss of pre-stress due to anchorage slip of 3 mm in a concrete beam of length of 30 m which is post-tensioned by a tendon subjected to an initial stress of 1200 N/mm^2 and modulus of elasticity equal to $2.1 \times 10^5 \text{ N/mm}^2$, is

- (a) 0.0175%
- (b) 0.175%
- (c) 1.75%
- (d) 17.5%

91. Engines are rated at specified conditions. Then which of the following statements are correct?

1. Power developed increases as local temperature increases.
2. Power developed increases as local temperature decreases.
3. Power developed is not dependent on local temperature.
4. Power developed increases as local atmospheric pressure increases.
5. Power developed increases as local atmospheric pressure decreases.

Select the correct answer using the code given below.

- (a) 1 and 4
- (b) 3 and 4
- (c) 3 and 5
- (d) 2 and 4

92. Consider the following statements in respect of 'mixers' :

1. Mass batch mixing of ingredients is the most desirable method.
2. Charging all materials into a drum mixer is done 'at once'.
3. The quantity of material fed into a mixer should be not more than the quantity that can be used in less than 30 minutes after completion of mixing.
4. Reversing mixers have less capacity than tilting mixers.
5. In large mixers, additional time of mixing is allowed.

Which of the above statements are correct?

- (a) 1, 2 and 3
- (b) 1, 3 and 5
- (c) 2, 3 and 4
- (d) 2, 4 and 5

93. Consider the following statements about 'cranes' :

1. Mobile cranes are suitable in small operations.
2. Whirley crane is a stationary crane with a long boom.
3. Tower crane is used in lifting heavy machinery.
4. A guy-derrick can operate in a limited area only.

Which of the above statements are correct?

- (a) 1 and 4
- (b) 2 and 4
- (c) 1 and 3
- (d) 2 and 3

94. Extracts from the head-discharge characteristics of two centrifugal pumps are tabulated with respective subscripts 1 and 2; manometric head h_m is given in metres; and discharge Q is given in lps :

| Q | 12 | 14 | 16 | 18 | 20 |
|-----------|------|------|------|------|------|
| h_{m_1} | 50.2 | 50.8 | 51.3 | 50.0 | 30.0 |
| h_{m_2} | 42.4 | 38.8 | 35.7 | 32.0 | 25.0 |

The pumps are connected in series against a static head of 80 m; the estimate of the total of head losses is $\frac{Q^2}{120}$ m. What is the delivered discharge?

- (a) 15.80 lps
- (b) 16.35 lps
- (c) 17.35 lps
- (d) 17.75 lps

95. Which system of network given below completely eliminates the use of dummy activities?

- (a) A-O-A (Activity-on-Arrow)
- (b) A-O-N (Activity-on-Node)
- (c) PERT
- (d) CPM

96. Free float can be associated with which of the following?

1. In one of two sub-paths between any two adjacent nodes
2. In the last activity in the sub-paths, less by at least one of the sub-paths, between any two nodes
3. Following all sub-activities in a ladder network
4. Whenever mandatory calendar dates are prescribed for major milestone events

Select the correct answer using the code given below.

- (a) 1, 2 and 3
- (b) 1, 3 and 4
- (c) 2, 3 and 4
- (d) 1, 2 and 4

97. In PERT analysis, the time estimates of activities follow

- (a) normal distribution curve
- (b) β -distribution curve
- (c) Poisson's distribution curve
- (d) binomial distribution curve

98. Three consecutive activities A, B and E (in that order) have their T—Duration (in days) vs. C—Direct Cost (in monetary units) relationship expressed in the following table :

| A | | B | | E | |
|----|----|---|---|---|----|
| T | C | T | C | T | C |
| 8 | 15 | 6 | 7 | 4 | 11 |
| 9 | 14 | 7 | 6 | 5 | 12 |
| 10 | 16 | 8 | 7 | 6 | 13 |

What is the optimum duration for the corresponding minimum total direct cost for all the three activities when taken up consecutively without pause or disruption?

- (a) 22 days
- (b) 21 days
- (c) 20 days
- (d) 19 days

99. In an Activity-on-Arrow network, which of the following rules of network logic are mandatory?

1. Any two events can be directly connected by not more than one activity.
2. Event numbers should not be duplicated in a network.
3. Before an activity may begin, all the activities preceding it must be completed.

Select the correct answer using the code given below.

- (a) 1 and 2 only
- (b) 2 and 3 only
- (c) 1 and 3 only
- (d) 1, 2 and 3

100. List the following processes in their correct sequence, from earliest to latest, in project implementation planning :

1. Project duration
2. Resource histogram
3. Standardized input/performance for each activity including alternatives
4. WBS
5. Resource optimization considering constraints
6. Activities and their inter-relationships

Select the correct answer using the code given below.

- (a) 2, 1, 3, 5, 6 and 4
- (b) 2, 6, 3, 5, 1 and 4
- (c) 4, 1, 3, 5, 6 and 2
- (d) 4, 6, 3, 5, 1 and 2

Directions :

Each of the following **twenty (20)** items consists of two statements, one labelled as 'Statement (I)' and the other as 'Statement (II)'. You are to examine these two statements and select the answers to these items using the code given below.

Code :

- (a) Both Statement (I) and Statement (II) are individually true and Statement (II) is the correct explanation of Statement (I)
- (b) Both Statement (I) and Statement (II) are individually true but Statement (II) is **not** the correct explanation of Statement (I)
- (c) Statement (I) is true but Statement (II) is false
- (d) Statement (I) is false but Statement (II) is true

101. Statement (I) :

Bricks are soaked in water before using in brick masonry for removing dirt and dust.

Statement (II) :

Bricks are soaked in water before using in brick masonry so that bricks do not absorb moisture from the bonding cement mortar.

102. Statement (I) :

Brick masonry in mud mortar is weak in strength.

Statement (II) :

Cement mortar enhances the strength of the bricks relative to mud mortar.

103. Statement (I) :

Quick-setting cement with initial setting time of 5 minutes is used in underwater constructions.

Statement (II) :

Aggregate and cement are mixed dry, and the mixture is then dumped in water.

104. Statement (I) :

Water needed for hydration decides the quantity of the water to be used in mortar preparation.

Statement (II) :

Excess water in mortar reduces its strength.

105. Statement (I) :

Preparing mortar by using masonry cement improves workability as well as the finish during plastering.

Statement (II) :

Masonry cement is easy to handle.

106. Statement (I) :

Grading of concrete is based on 28-day strength.

Statement (II) :

Concrete does not gain any further strength after 28-day curing.

107. Statement (I) :

Addition of admixture improves the workability of concrete.

Statement (II) :

Addition of admixture increases the strength of concrete.

108. Statement (I) :

There are two independent elastic constants for an isotropic material.

Statement (II) :

All metals at micro-level are isotropic.

109. Statement (I) :

Mohr's theory is based on logical arrangement of experimental results.

Statement (II) :

Mohr's theory generalizes Coulomb's theory.

110. Statement (I) :

The most-suited failure theory for concrete is maximum shear strength theory.

Statement (II) :

Ductile materials are limited by their shear strength.

111. Statement (I) :

In simple bending, strain in the bent beam varies linearly across the beam depth.

Statement (II) :

As per Hooke's law, within elastic limit, the stress is proportional to the strain.

112. Statement (I) :

The failure surface of a standard cast iron specimen of circular cross-section subjected to torsion is on a helicoidal surface at 45° to its axis.

Statement (II) :

The failure occurs on a plane of the specimen subjected to maximum tensile stress, and cast iron is weak in tension.

113. Statement (I) :

A simply supported beam AB of constant EI throughout, when subjected to pure terminal couples as shown in the figure, will bend into an arc of a circle.

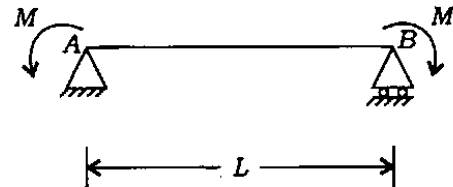

Statement (II) :

Theory of simple bending establishes relationships from among M , f , R , y , E and I .

114. Statement (I) :

Concrete of desired strength can be achieved by weight-batching method.

Statement (II) :

Volume-batching method does not take into account bulking of aggregates, hence concrete of desired strength cannot be achieved by volume-batching.

115. Statement (I) :

Hoe is not very advantageous in digging trenches and basements.

Statement (II) :

In a hoe, the digging action results from the drag of the bucket.

116. Statement (I) :

In close-range works of excavation, power shovel is suitable.

Statement (II) :

Power shovel has greater rigidity and gives greater output than draglines.

117. Statement (I) :

Reciprocating pump is self-priming.

Statement (II) :

Reciprocating pump is used to pump dirty water in excavations.

118. Statement (I) :

A linked-bar chart is premised on a resource-based scheduled network, and so is unique to the relevant project.

Statement (II) :

A squared scheduled network drawn after allocating activity durations, with consideration of floats that have been originally available, may yet have the inputs-scheduling pending.

119. Statement (I) :

A dummy job takes zero time to perform.

Statement (II) :

It is used solely to illustrate precedence relationship.

120. Statement (I) :

In resource levelling, project completion time is not extended provided there is no constraint on availability of resources.

Statement (II) :

There is generally a constraint against exceeding the project duration time.

SPACE FOR ROUGH WORK

evidyarthi.in

SPACE FOR ROUGH WORK

evidyarthi.in

SPACE FOR ROUGH WORK

evidyarthi.in
