

# AIPMT

## SAMPLE PAPERS WITH SOLUTIONS

1. Which one of the following pairs of structures is correctly matched with their correct description?

	Structures		Description
(1)	Tibia and fibula	-	Both form parts of knee joint
(2)	Cartilage and cornea	-	No blood supply but do require oxygen for respiratory need
(3)	Shoulder joint and elbow joint	-	Ball and socket type of joint
(4)	Premolars and molars	-	20 in all and 3-rooted

**Ans. (2)**

**Sol.** Cartilage is avascular, as the blood vessels innervate only perichondrium. In the formation of knee joint, tibia is involved with femur.

2. Identify the components labelled A, B, C and D in the diagram below from the list (i) to (viii) given along with



**Components:**

- (i) Cristae of mitochondria
- (ii) Inner membrane of mitochondria
- (iii) Cytoplasm
- (iv) Smooth endoplasmic reticulum
- (v) Rough endoplasmic reticulum
- (vi) Mitochondrial matrix
- (vii) Cell vacuole
- (viii) Nucleus

The correct components are :

	A	B	C	D
(1)	(v)	(iv)	(viii)	(iii)
(2)	(i)	(iv)	(viii)	(vi)
(3)	(vi)	(v)	(iv)	(vii)
(4)	(v)	(i)	(iii)	(ii)

**Ans. (1)**

**Sol.** Golgi and ER are often found associated to nuclear membrane.

3. Fastest distribution of some injectible material/ medicine and with no risk of any kind can be achieved by injecting it into the

- (1) Muscles
- (2) Arteries
- (3) Veins
- (4) Lymph vessels

**Ans. (3)**

**Sol.** Intravenous injection is given for rapid distribution of drugs/substance. Intramuscular injection is given for producing local effect.

4. Which one of the following statements about the particular entity is true?
- (1) *Centromere* is found in animal cells, which produces aster during cell division
  - (2) The *gene for producing insulin* is present in every body cell
  - (3) *Nucleosome* is formed of nucleotides
  - (4) *DNA* consists of a core of eight histones

Ans. (2)

Sol. 'Centromere' is found in chromosomes where two chromatids are attached.

'Insulin' gene is found in every body cell but is not expressed in all cells.

5. Study the pedigree chart of a certain family given below and select the **correct** conclusion which can be drawn for the character

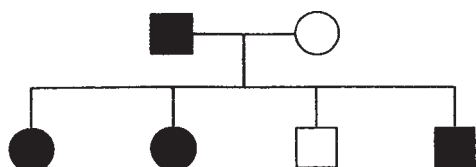

- (1) The female parent is heterozygous
- (2) The parents could not have had a normal daughter for this character
- (3) The trait under study could not be colour-blindness
- (4) The male parent is homozygous dominant

Ans. (1)

Sol.  $aa$  —  $Aa$

6. Leguminous plants are able to fix atmospheric nitrogen through the process of symbiotic nitrogen fixation. Which one of the following statements is **not** correct during this process of nitrogen fixation?
- (1) Leghaemoglobin scavenges oxygen and is pinkish in colour
  - (2) Nodules act as sites for nitrogen fixation
  - (3) The enzyme nitrogenase catalyses the conversion of atmospheric  $N_2$  to  $NH_3$
  - (4) Nitrogenase is insensitive to oxygen

Ans. (4)

Sol. Nitrogenase is sensitive against  $O_2$ .

7. Which one of the following is a xerophytic plant in which the stem is modified into the flat green and succulent structure?
- (1) *Opuntia*
  - (2) *Casuarina*
  - (3) *Hydrilla*
  - (4) *Acacia*

Ans. (1)

Sol. *Opuntia* – Phylloclade

8. The figure given below shows the conversion of a substrate into product by an enzyme. In which one of the four options (1–4) the components of reaction labelled as A, B, C and D are identified correctly?

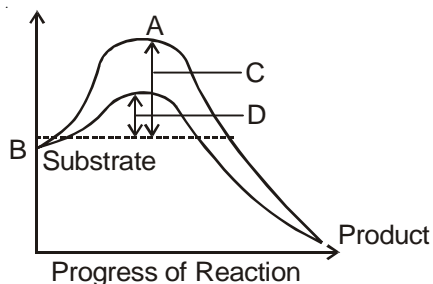

Options:

	A	B	C	D
(1)	Potential energy	Transition state	Activation energy with enzyme	Activation energy without enzyme
(2)	Transition state	Potential energy	Activation energy without enzyme	Activation energy with enzyme
(3)	Potential energy	Transition state	Activation energy with enzyme	Activation energy without enzyme
(4)	Activation energy with enzyme	Transition state	Activation energy without enzyme	Potential energy

Ans. (2)

Sol. Activation energy is required for overcoming the energy barrier which gets reduced in the presence of enzyme.

9. Which of the following are used in gene cloning?

- (1) Nucleoids
- (2) Lomasomes
- (3) Mesosomes
- (4) Plasmids

Ans. (4)

Sol. Plasmids are used as the vector in gene cloning.

10. When domestic sewage mixes with river water

- (1) Small animals like rats will die after drinking river water
- (2) The increased microbial activity releases micro-nutrients such as iron
- (3) The increased microbial activity uses up dissolved oxygen
- (4) The river water is still suitable for drinking as impurities are only about 0.1%

Ans. (3)

Sol. Any mixing of sewage will increase BOD and decrease of DO due to decomposing activity of microbes.

11. Given below are four statements (A-D) each with one or two blanks. Select the option which **correctly** fills up the blanks in two statements

**Statements:**

- (A) Wings of butterfly and birds look alike and are the results of (i), evolution.  
 (B) Miller showed that  $\text{CH}_4$ ,  $\text{H}_2$ ,  $\text{NH}_3$  and (i), when exposed to electric discharge in a flask resulted in formation of (ii).  
 (C) Vermiform appendix is a (i) organ and an (ii) evidence of evolution.  
 (D) According to Darwin evolution took place due to (i) and (ii) of the fittest.

**Options :**

- (1) (D) – (i) Small variations, (ii) Survival,  
 (A) – (i) Convergent  
 (2) (A) – (i) Convergent,  
 (B) – (i) Oxygen, (ii) nucleosides  
 (2) (B) – (i) Water vapour, (ii) Amino acids  
 (C) – (i) Rudimentary, (ii) Anatomical  
 (4) (C) – (i) Vestigial, (ii) Anatomical  
 (D) – (i) Mutations, (ii) Multiplication

**Ans. (1)**

**Sol.** According to Darwin, evolution took place due to small variations & survival of the fittest. Wings of butterfly & birds are analogous or convergent. Vermiform appendix is vestigial organ.

12. Aestivation of petals in the flower of cotton is correctly shown in 1

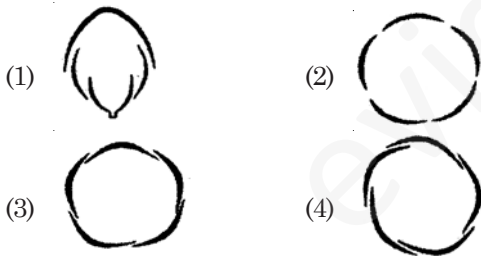

**Ans. (4)**

**Sol.** Lady's finger, cotton and china rose, all shows twisted aestivation.

13. In which one of the following organisms its **excretory organs** are **correctly** stated?

- (1) Humans – Kidneys, sebaceous glands and tear glands  
 (2) Earthworm – Pharyngeal, integumentary and septal nephridia  
 (3) Cockroach – Malpighian tubules and enteric caeca  
 (4) Frog – Kidneys, skin and buccal epithelium

**Ans. (2)**

**Sol.** Earthworm has 3 types of nephridia.

14. Examine the figures A, B, C and D. In which one of the four options all the items A, B, C and D are correct?

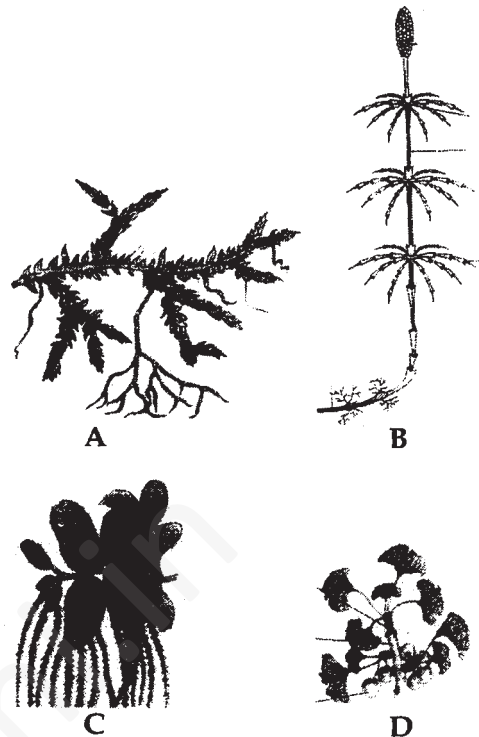

**Options:**

	A	B	C	D
(1)	<i>Chara</i>	<i>Marchantia</i>	<i>Fucus</i>	<i>Pinus</i>
(2)	<i>Equisetum</i>	<i>Ginkgo</i>	<i>Selaginella</i>	<i>Lycopodium</i>
(3)	<i>Selaginella</i>	<i>Equisetum</i>	<i>Salvinia</i>	<i>Ginkgo</i>
(4)	<i>Funaria</i>	<i>Adiantum</i>	<i>Salvinia</i>	<i>Riccia</i>

**Ans. (3)**

**Sol.** A – *Selaginella*, B – *Equisetum*, C – *Salvinia*, D – *Ginkgo*

15. The most apparent change during the evolutionary history of *Homo sapiens* is traced in

- (1) Loss of body hair  
 (2) Walking upright  
 (3) Shortening of the jaws  
 (4) Remarkable increase in the brain size

**Ans. (4)**

**Sol.** Brain size or cranial capacity shows gradual increases in history of *Homo sapiens*.

16. Which one of the following is now being commercially produced by biotechnological procedures?

- (1) Nicotine (2) Morphine  
 (3) Quinine (4) Insulin

**Ans. (4)**

**Sol.** Insulin is produced by synthesizing the polypeptide A and polypeptide B separately and then linking them.

17. The correct floral formula of soybean is

- (1)  $\% \overset{\text{♂}}{\text{K}}_{(5)} \text{C}_{1+(2)+2} \text{A}_{(9)+1} \text{G}_{\bar{1}}$   
 (2)  $\% \overset{\text{♂}}{\text{K}}_5 \text{C}_{1+(2)+2} \text{A}_{(9)+1} \text{G}_{\bar{1}}$   
 (3)  $\% \overset{\text{♂}}{\text{K}}_{(5)} \text{C}_{1+2+(2)} \text{A}_{(9)+1} \text{G}_{\bar{1}}$   
 (4)  $\% \overset{\text{♂}}{\text{K}}_{(5)} \text{C}_{1+2+(2)} \text{A}_{1+(9)} \text{G}_{\bar{1}}$

Ans. (3)

Sol.  $\% \overset{\text{♂}}{\text{K}}_{(5)} \text{C}_{1+2+(2)} \text{A}_{(9)+1} \text{G}_{\bar{1}}$  (w.r.t. NCERT)

18. If for some reason the parietal cells of the gut epithelium become partially non-functional, what is likely to happen?

- (1) The pancreatic enzymes and specially the trypsin and lipase will not work efficiently  
 (2) The pH of stomach will fall abruptly  
 (3) Steapsin will be more effective  
 (4) Proteins will not be adequately hydrolysed by pepsin into proteoses and peptones

Ans. (4)

Sol. Parietal or oxyntic cells release HCl required for the activation of pepsin.

19. Which one of the following is *most appropriately* defined?

- (1) Host is an organism which provides food to another organism  
 (2) *Amensalism* is a relationship in which one species is benefited whereas the other is unaffected  
 (3) *Predator* is an organism that catches and kills other organism for food  
 (4) *Parasite* is an organism which always lives inside the body of other organism and may kill it

Ans. (3)

Sol. Term 'Host' is specific to parasitic relation only.

20. Read the following four statements, A, B, C and D and select the right option having both correct statements.

STATEMENTS :

- (A) Z scheme of light reaction takes place in presence of PSI only.  
 (B) Only PS I is functional in cyclic photophosphorylation.  
 (C) Cyclic photophosphorylation results into synthesis of ATP and NADPH<sub>2</sub>  
 (D) Stroma lamellae lack PS II as well as NADP.

Options :

- (1) B and D (2) A and B  
 (3) B and C (4) C and D

Ans. (1)

Sol. It requires both PS-II and PS-I, where PS-II is more important. Stroma lamella contains PS-I only.

21. Which one of the following techniques is safest for the detection of cancers?

- (1) Magnetic resonance imaging (MRI)  
 (2) Radiography (X-ray)  
 (3) Computed tomography (CT)  
 (4) Histopathological studies

Ans. (1)

Sol. Histopathological study is the invasive technique. Radiography and CT involves X-rays which are harmful.

22. Signals from fully developed foetus and placenta ultimately lead to parturition which requires the release of

- (1) Estrogen from placenta  
 (2) Oxytocin from maternal pituitary  
 (3) Oxytocin from foetal pituitary  
 (4) Relaxin from placenta

Ans. (2)

Sol. Oxytocin or Pitocin released from maternal pituitary causes contractions in the uterine muscles to help in parturition.

23. Select the *correct* matching of a hormone, its source and function.

	Hormone	Source	Function
(1)	Vasopressin	Posterior pituitary	Increases loss of water through urine
(2)	Norepinephrine	Adrenal medulla	Increases heart beat, rate of respiration and alertness
(3)	Glucagon	Beta-cells of Islets of langerhans	Stimulates glycogenolysis
(4)	Prolactin	Posterior Pituitary	Regulates growth of mammary glands and milk formation in females

Ans. (2)

Sol. Vasopressin decreases loss of water through urine. Glucagon is released from  $\alpha$ -cells. Prolactin is released from anterior pituitary.

24. In eukaryotic cell transcription, RNA splicing and RNA capping take place inside the

- (1) Ribosomes (2) Nucleus  
 (3) Dictyosomes (4) ER

Ans. (2)

Sol. Mature mRNA comes out in cytoplasm only after completion of splicing, capping and tailing.

25. Given below are four statements (a-d) regarding human blood circulatory system
- Arteries are thick-walled and have narrow lumen as compared to veins
  - Angina is acute chest pain when the blood circulation to the brain is reduced
  - Persons with blood group AB can donate blood to any person with any blood group under ABO system
  - Calcium ions play a very important role in blood clotting

Which two of the above statements are correct?

- (a) & (d)
- (a) & (b)
- (b) & (c)
- (c) & (d)

**Ans. (1)**

**Sol.** Angina is due to reduced blood supply to heart wall. Person with blood group AB is universal recipient.

26. In human female the *blastocyst*

- Forms placenta even before implantation
- Gets implanted into uterus 3 days after ovulation
- Gets nutrition from uterine endometrial secretion only after implantation
- Gets implanted in endometrium by the trophoblast cells

**Ans. (4)**

**Sol.** Blastocyst starts getting nutrition before implantation.

27. The haemoglobin content per 100 ml of blood of a normal healthy human adult is

- 5 - 11 g
- 25 - 30 g
- 17 - 20 g
- 12 - 16 g

**Ans. (4)**

28. An example of endomycorrhiza is

- Nostoc*
- Glomus*
- Agaricus*
- Rhizobium*

**Ans. (2)**

**Sol.** *Nostoc* - BGA, *Agaricus*- Basidiomycetes, *Rhizobium* - Eubacteria

29. One of the commonly used plant growth hormone is tea plantations is

- Ethylene
- Abscisic acid
- Zeatin
- Indole - 3 - acetic acid

**Ans. (4)**

**Sol.** Auxins are commonly used in stem cutting.

30. Study the cycle shown below and select the option which gives correct words for all the four blanks A, B, C and D.

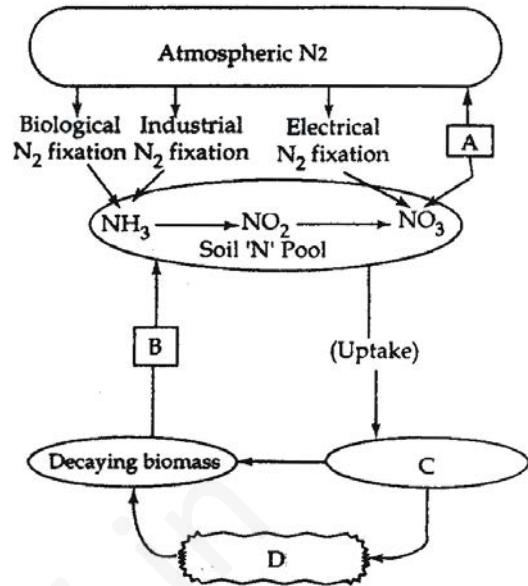

**Options:**

	A	B	C	D
(1)	Nitrification	Ammonification	Animals	Plants
(2)	Denitrification	Ammonification	Plants	Animals
(3)	Nitrification	Denitrification	Animals	Plants
(4)	Denitrification	Nitrification	Plants	Animals

**Ans. (2)**

**Sol.** A – Denitrification, B – Ammonification, C – Plants, D-Animals

31. Jaundice is a disorder of

- Excretory system
- Skin and eyes
- Digestive system
- Circulatory system

**Ans. (3)**

**Sol.** Jaundice can be due to blockage/inflammation of bile duct.

32. Kranz anatomy is one of the characteristics of the leaves of

- Potato
- Wheat
- Sugarcane
- Mustard

**Ans. (3)**

**Sol.** Sugarcane – C<sub>4</sub> plant



33. In *Antirrhinum* two plants with pink flowers were hybridized. The  $F_1$  plants produced red, pink and white flowers in the proportion of 1 red, 2 pink and 1 white. What could be the genotype of the two plants used for hybridization? Red flower colour is determined by  $RR$ , and white by  $rr$  genes.

- (1)  $rrrr$                       (2)  $RR$   
(3)  $Rr$                          (4)  $rr$

Ans. (3)

Sol. Parents (Pink)  $Rr \times Rr$  (Pink)

Gametes  $R, r$                        $R, r$

	R	r	
R	RR	Rr	1 : 2 : 1 Red : Pink : White
r	Rr	rr	

34. Transport of food material in higher plants takes place through

- (1) Companion cells              (2) Transfusion tissue  
(3) Tracheids                      (4) Sieve elements

Ans. (4)

Sol. Sieve elements – Major transporting element of food.

**Transfusion tissue** – In place of lateral viens in gymnosperm leaves.

35. Which one of the following is monoecious?

- (1) *Marchantia*                      (2) *Cycas*  
(3) *Pinus*                              (4) *Date palm*

Ans. (3)

Sol. Both male and female cones occur or same plant in *Pinus*.

36. A cross in which an organism showing a dominant phenotype in crossed with the recessive parent in order to know its genotype is called :

- (1) Monohybrid cross              (2) Back cross  
(3) Test cross                         (4) Dihybrid cross

Ans. (3)

Sol. Back cross include cross of  $F_1$  with any of the parents i.e.,  $(Tt \times tt)$  or  $(Tt \times TT)$ .

37. The Indian Rhinoceros is a natural inhabitant of which one of the Indian states?

- (1) Uttarakhand                      (2) Uttar Pradesh  
(3) Himachal Pradesh              (4) Assam

Ans. (4)

Sol. Kaziranga National Park is famous for rhinoceros.

38. Study the pathway given below :

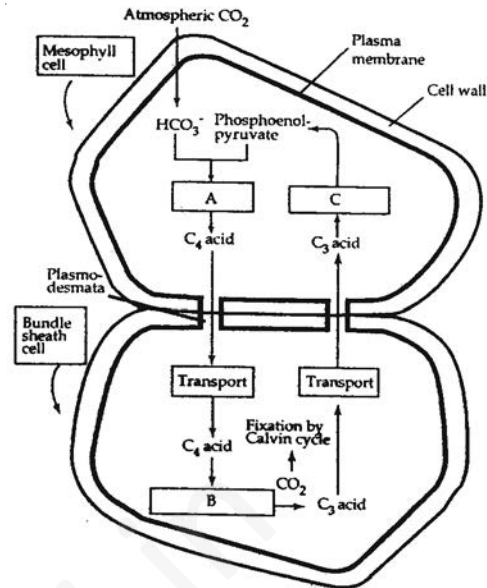

In which of the following options correct words for all the three blanks A, B and C are indicated?

	A	B	C
(1)	Decarboxylation	Reduction	Regeneration
(2)	Fixation	Transamination	Regeneration
(3)	Fixation	Decarboxylation	Regeneration
(4)	Carboxylation	Decarboxylation	Reduction

Ans. (3)

Sol. A – Fixation of  $CO_2$  by PEPCO

B – Decarboxylation

C – Regeneration

39. Black (stem) rust of wheat is caused by :

- (1) *Alternaria solani*              (2) *Ustilago nuda*  
(3) *Puccinia graminis*              (4) *Xanthomonas oryzae*

Ans. (3)

Sol. *Puccinia graminis tritici* - Black stem rust of wheat.

40. Secretions from which one of the following are rich in fructose, calcium and some enzymes?

- (1) Male accessory glands  
(2) Liver  
(3) Pancreas  
(4) Salivary glands

Ans. (1)

Sol. Male accessory glands include a pair of seminal vesicles, a prostate gland, and pair of bulbourethral glands. Their secretions is called as seminal plasma, which is rich in fructose, has calcium and some enzymes.

41. A person suffering from a disease caused by *Plasmodium*, experiences recurring chill and fever at the time when?

- (1) The sporozoites released from RBCs are being rapidly killed and broken down inside spleen
- (2) The trophozoites reach maximum growth and give out certain toxins
- (3) The parasite after its rapid multiplication inside RBCs ruptures them, releasing the stage to enter fresh RBCs
- (4) The microgametocytes and megagametocytes are being destroyed by the WBCs

**Ans. (3)**

**Sol.** In malaria chill and fever is due to the release of haemozoin, a toxic substance formed by breakdown of haemoglobin present in RBC. It will be released after the rupture of RBC, in erythrocytic schizogamy.

42. ABO blood grouping is controlled by gene I which has three alleles and show co-dominance. There are six genotypes. How many phenotypes in all are possible?

- (1) Six
- (2) Three
- (3) Four
- (4) Five

**Ans. (3)**

**Sol.** A, B, AB and O.

43. Three of the following statements about enzymes are correct and one is wrong. Which one is wrong?

- (1) Enzymes require optimum pH for maximal activity
- (2) Enzymes are denatured at high temperature but in certain exceptional organisms they are effective even at temperatures 80°-90°C
- (3) Enzymes are highly specific
- (4) Most enzymes are proteins but some are lipids

**Ans. (4)**

**Sol.** Most enzymes are proteins but some are RNA enzymes.

44. An elaborate network of filamentous proteinaceous structures present in the cytoplasm which helps in the maintenance of cell shape is called :

- (1) Thylakoid
- (2) Endoplasmic Reticulum
- (3) Plasmalemma
- (4) Cytoskeleton

**Ans. (4)**

**Sol.** Cytoskeleton-Microtubule, Microfilament and Intermediate filaments.

45. Examine the figures (A-D) given below and select the right option out of 1-4, in which all the four structures A, B, C and D are identified correctly

**Structures :**

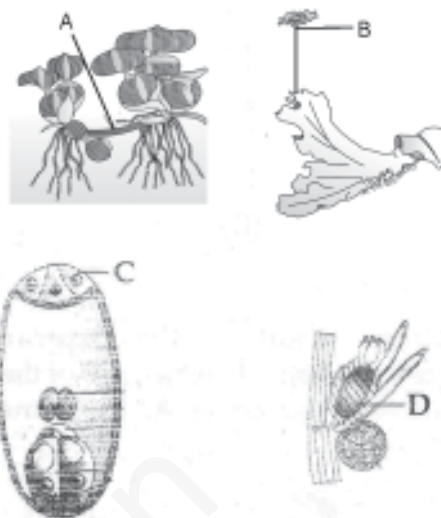

**Options :**

	A	B	C	D
(1)	Rhizome	Sporangiophore	Polar cell	Globule
(2)	Runner	Archegoniophore	Synergid	Antheridium
(3)	Offset	Antheridiophore	Antipodals	Oogonium
(4)	Sucker	Seta	Megaspore mother cell	Gemma cup

**Ans. (3)**

**Sol.** A – Offset of *Eichhornia*

B – Antheridiophore of *Marchantia*

C – Antipodals

D – Oogonium (Nucule) of *Chara*

46. Root development is promoted by

- (1) Abscisic acid
- (2) Auxin
- (3) Gibberellin
- (4) Ethylene

**Ans. (4)**

**Sol.** Root development and root hair formation  $C_2H_4$ .

47. Consider the following four statements A, B, C and D and select the right option for two **correct** statements.

**Statements**

(A) In vexillary aestivation, the large posterior petal is called - *standard*, two lateral ones are called *wings* and two small anterior petals are termed *keel*

(B) The floral formula for Liliaceae is

$$\oplus \overline{\ominus} P_{3+3} A_{3+3} + G_3$$

(C) In pea flower the stamens are monadelphous

(D) The floral formula for Solanaceae is

$$\oplus \overline{\ominus} K_{(3)} C_{(3)} A_{(4)} + G_{(2)}$$

The correct statements are

- (1) (A) and (C)
- (2) (A) and (B)
- (3) (B) and (C)
- (4) (C) and (D)

**Ans. (2)**

**Sol.** Pea-Diadelphous.

48. Given below is the diagram of a bacteriophage. In which one of the options all the four parts A, B, C and D are correct?

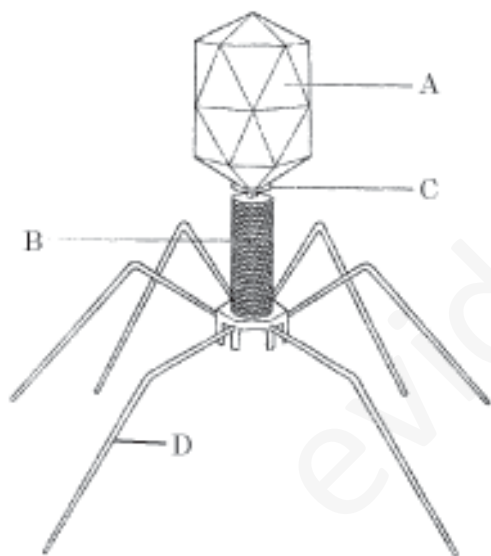

**Options :**

	A	B	C	D
(1)	Tail fibres	Head	Sheath	Collar
(2)	Sheath	Collar	Head	Tail fibres
(3)	Head	Sheath	Collar	Tail fibres
(4)	Collar	Tail fibres	Head	Sheath

**Ans. (3)**

**Sol.** A - Head

B - Sheath

C - Collar

D - Tail fibre

49. In genetic engineering, a DNA segment (gene) of interest, is transferred to the host cell through a vector. Consider the following four agents (A-D) in this regard and select the correct option about which one or more of these can be used as a vector/vectors

**Statements**

- (A) A bacterium (B) Plasmid  
(C) Plasmodium (D) Bacteriophage

**Options :**

- (1) (A), (B) and (D) only (2) (A) only  
(3) (A) and (C) only (4) (B) and (D) only

**Ans. (4)**

**Sol.** Plasmids and bacteriophages are used as vectors in genetic engineering.

50. Which one of the following can **not** be used for preparation of vaccines against plague?

- (1) Formalin-inactivated suspensions of virulent bacteria
- (2) Avirulent live bacteria
- (3) Synthetic capsular polysaccharide material
- (4) Heat-killed suspensions of virulent bacteria

**Ans. (3)**

**Sol.** Synthetic capsular polysaccharide vaccines are available for treatment of pneumonia caused by

*Streptococcus pneumoniae*

*Hemophilus influenza*

and for meningitidis caused by *Neisseria meningitidis*.

They are not available for plague.

51. The fruit fly *Drosophila melanogaster* was found to be very suitable for experimental verification of chromosomal theory of inheritance by Morgan and his colleagues because :

- (1) It reproduces parthenogenetically
- (2) A single mating produces two young flies
- (3) Smaller female is easily recognisable from larger male
- (4) It completes life cycle in about two weeks

**Ans. (4)**

**Sol.** Female is larger. Many offsprings are produced from single mating.



52. The *lac* operon consists of
- (1) Four regulatory genes only
  - (2) One regulatory gene and three structural genes
  - (3) Two regulatory genes and two structural genes
  - (4) Three regulatory genes and three structural genes

**Ans. (2)**

**Sol.** Regulatory gene - 'i', structural genes - z, y, a

53. Crocodile and penguin are similar to Whale and Dogfish in which one of the following features?
- (1) Possess a solid single stranded central nervous system
  - (2) Lay eggs and guard them till they hatch
  - (3) Possess bony skeleton.
  - (4) Have gill slits at some stage

**Ans. (4)**

**Sol.** Crocodile, Penguin, Whale and Dogfish all are chordates. So, all have gill slits at some stage of development.

54. Select the answer with *correct matching* of the structure, its location and function

	Structure	Location	Function
(1)	Eustachian tube	Anterior part of internal ear	Equalizes air pressure on either sides of tympanic membrane
(2)	Cerebellum	Mid brain	Controls respiration and gastric secretions
(3)	Hypothalamus	Fore brain	Controls body temperature, urge for eating and drinking
(4)	Blind spot	Near the place where optic nerve leaves the eye	Rods and cones are present but inactive here

**Ans. (3)**

**Sol.** Hypothalamus is the floor of diencephalon which is the part of fore brain. It has thermoregulatory centre, hunger and thirst centre.

55. Select the correct combination of the statements (a-d) regarding the *characteristics* of certain organisms
- (a) Methanogens are Archaeobacteria which produce methane in marshy areas
  - (b) *Nostoc* is a filamentous blue-green alga which fixes atmospheric nitrogen
  - (c) Chemosynthetic autotrophic bacteria synthesize cellulose from glucose
  - (d) Mycoplasma lack a cell wall and can survive without oxygen

The correct statement are

- (1) (b), (c)
- (2) (a), (b), (c)
- (3) (b), (c), (d)
- (4) (a), (b), (d)

**Ans. (4)**

**Sol.** Chemosynthetic autotrophs oxidize inorganic substances to produce energy and helps cycling of minerals.

56. Which one of the following is the *correct description* of a certain part of a normal human skeleton?
- (1) Parietal bone and the temporal bone of the skull are joined by fibrous joint
  - (2) First vertebra is axis which articulates with the occipital condyles
  - (3) The 9<sup>th</sup> and 10<sup>th</sup> pairs of ribs are called the floating ribs
  - (4) Glenoid cavity is a depression to which the thigh bone articulates

**Ans. (1)**

**Sol.** Immovable/fixed/fibrous joint are present between the skull bones. So, between parietal bone and the temporal bone of the skull are joined by fibrous joint.

57. Vegetative propagation in *Pistia* occurs by

- (1) Stolon
- (2) Offset
- (3) Runner
- (4) Sucker

**Ans. (2)**

**Sol.** *Lemna*, *Pistia*, *Eichhornia* - Offset

58. Given below is the diagram of a stomatal apparatus. In which of the following all the four parts labelled as A, B, C and D are correctly identified?

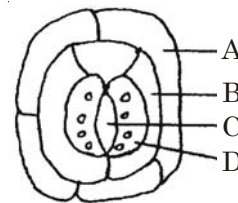

	A	B	C	D
(1)	Subsidiary cell	Epidermal cell	Guard cell	Stomatal aperture
(2)	Guard cell	Stomatal aperture	Subsidiary cell	Epidermal cell
(3)	Epidermal cell	Guard cell	Stomatal aperture	Subsidiary cell
(4)	Epidermal cell	Subsidiary cell	Stomatal aperture	Guard cell

**Ans. (4)**

**Sol.** A-Epidermal cell, B-Subsidiary cell, C-Stomatal aperture, D-Guard cell

59. Which of the following representations shows the pyramid of numbers in a forest ecosystem?

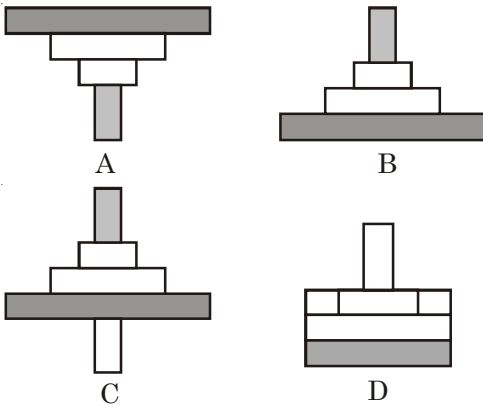

- (1) D                      (2) A  
(3) B                      (4) C

**Ans. (3)**

**Sol.** Pyramid of number is inverted in single tree ecosystem only.

60. The 3'-5' phosphodiester linkages inside a polynucleotide chain serve to join

- (1) One DNA strand with the other DNA strand  
(2) One nucleoside with another nucleoside  
(3) One nucleotide with another nucleotide  
(4) One nitrogenous base with pentose sugar

**Ans. (3)**

**Sol.** 3'-5' phosphodiester bond is formed between carbon 3 of one nucleotide and carbon 5 of the other nucleotide.

61. A current loop consists of two identical semicircular parts each of radius  $R$ , one lying in the  $x$ - $y$  plane and the other in  $x$ - $z$  plane. If the current in the loop is  $i$ . The resultant magnetic field due to the two semicircular parts at their common centre is

- (1)  $\frac{\mu_0 i}{2\sqrt{2}R}$                       (2)  $\frac{\mu_0 i}{2R}$   
(3)  $\frac{\mu_0 i}{4R}$                               (4)  $\frac{\mu_0 i}{\sqrt{2}R}$

**Ans. (1)**

**Sol.**  $\vec{B} = \vec{B}_1 + \vec{B}_2$

$$|\vec{B}_1| = |\vec{B}_2| = \frac{\mu_0 i}{4R}$$

$$|\vec{B}| = \sqrt{B_1^2 + B_2^2}$$

$$|\vec{B}| = \frac{\mu_0 i}{4R} \sqrt{2} = \frac{\mu_0 i}{2\sqrt{2}R}$$

62. The following figure shows a logic gate circuit with two inputs  $A$  and  $B$  and the output  $Y$ . The voltage waveforms of  $A$ ,  $B$  and  $Y$  are as given

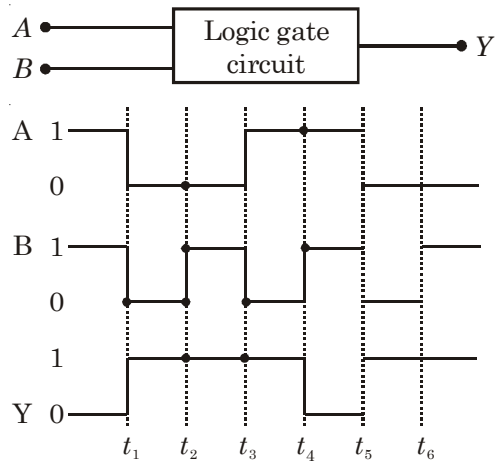

The logic gate is

- (1) NOR gate                      (2) OR gate  
(3) AND gate                      (4) NAND gate

**Ans. (4)**

**Sol.**

A	B	Y
1	1	0
0	0	1
0	1	1
1	0	1

63. Two parallel metal plates having charges  $+Q$  and  $-Q$  face each other at a certain distance between them. If the plates are now dipped in kerosene oil tank, the electric field between the plates will

- (1) Become zero                      (2) Increase  
(3) Decrease                              (4) Remain same

**Ans. (3)**

**Sol.** Electric field in vacuum

$$E_0 = \frac{\sigma}{\epsilon_0}$$

In medium

$$E = \frac{\sigma}{\epsilon_0 K}$$

$$K > 1$$

$$E < E_0$$

64. The electric field at a distance  $\frac{3R}{2}$  from the centre of a charged conducting spherical shell of radius  $R$  is  $E$ . The electric field at a distance  $\frac{R}{2}$  from the centre of the sphere is

- (1) Zero (2)  $E$   
(3)  $\frac{E}{2}$  (4)  $\frac{E}{3}$

**Ans. (1)**

**Sol.** Electric field inside shell is zero.

65. A student measures the distance traversed in free fall of a body, initially at rest in a given time. He uses this data to estimate  $g$ , the acceleration due to gravity. If the maximum percentage errors in measurement of the distance and the time are  $e_1$  and  $e_2$  respectively, the percentage error in the estimation of  $g$  is

- (1)  $e_2 - e_1$  (2)  $e_1 + 2e_2$   
(3)  $e_1 + e_2$  (4)  $e_1 - 2e_2$

**Ans. (2)**

**Sol.**  $\ln g = \ln h - 2 \ln t$

$$\left(\frac{\Delta g}{g} \times 100\right)_{\max} = \frac{\Delta h}{h} \times 100 + 2 \frac{\Delta t}{t} \times 100$$

$$= e_1 + 2e_2$$

66. When monochromatic radiation of intensity  $I$  falls on a metal surface, the number of photoelectron and their maximum kinetic energy are  $N$  and  $T$  respectively. If the intensity of radiation is  $2I$ , the number of emitted electrons and their maximum kinetic energy are respectively

- (1)  $N$  and  $2T$  (2)  $2N$  and  $T$   
(3)  $2N$  and  $2T$  (4)  $N$  and  $T$

**Ans. (2)**

**Sol.** Number of photoelectrons  $\propto$  Intensity

Maximum kinetic energy is independent of intensity

67. The electric field of an electromagnetic wave in free space is given by

$\vec{E} = 10 \cos(10^7 t + kx) \hat{j}$  V/m, where  $t$  and  $x$  are in seconds and metres respectively. It can be inferred that

- (a) The wavelength  $\lambda$  is 188.4 m  
(b) The wave number  $k$  is 0.33 rad/m  
(c) The wave amplitude is 10 V/m  
(d) The wave is propagating along  $+x$  direction

Which one of the following pairs of statements is correct?

- (1) (c) & (d) (2) (a) and (b)  
(3) (b) & (c) (4) (a) & (c)

**Ans. (4)**

**Sol.** Amplitude =  $10 \frac{V}{m}$

$$C = \frac{\omega}{k}$$

$$3 \times 10^8 = \frac{10^7}{k}$$

$$k = \frac{1}{30}$$

$$\frac{2\pi}{\lambda} = \frac{1}{30}$$

$$\lambda = 188.4 \text{ m}$$

68. The speed of light in media  $M_1$  and  $M_2$  is  $1.5 \times 10^8$  m/s and  $2.0 \times 10^8$  m/s respectively. A ray of light enters from medium  $M_1$  to  $M_2$  at an incidence angle  $i$ . If the ray suffers total internal reflection, the value of  $i$  is

- (1) Equal to  $\sin^{-1}\left(\frac{2}{3}\right)$   
(2) Equal to or less than  $\sin^{-1}\left(\frac{3}{5}\right)$   
(3) Equal to or greater than  $\sin^{-1}\left(\frac{3}{4}\right)$   
(4) Less than  $\sin^{-1}\left(\frac{2}{3}\right)$

**Ans. (3)**

**Sol.**  $\mu_1 = 2$

$$\mu_2 = \frac{3}{2}$$

$$2 \sin i \geq \frac{3}{2} \sin 90$$

$$\sin i \geq \frac{3}{4}$$

$$i \geq \sin^{-1}\left(\frac{3}{4}\right)$$

69. A ray of light is incident on a  $60^\circ$  prism at the minimum deviation position. The angle of refraction at the first face (i.e., incident face) of the prism is

- (1) Zero (2)  $30^\circ$   
(3)  $45^\circ$  (4)  $60^\circ$

Ans. (2)

Sol. In minimum deviation

$$r_1 = r_2 = r$$

$$A = 2r$$

$$r = \frac{60}{2} = 30^\circ$$

70. For transistor action

- (a) Base, emitter and collector regions should have similar size and doping concentrations.  
(b) The base region must be very thin and lightly doped.  
(c) The emitter-base junction is forward biased and base-collector junction is reverse biased.  
(d) Both the emitter-base junction as well as the base collector junction are forward biased.

Which one of the following pairs of statements is correct?

- (1) (d), (a) (2) (a), (b)  
(3) (b), (c) (4) (c), (d)

Ans. (3)

71. The additional kinetic energy to be provided to a satellite of mass  $m$  revolving around a planet of mass  $M$ , to transfer it from a circular orbit of radius  $R_1$  to another of radius  $R_2$  ( $R_2 > R_1$ ) is

- (1)  $GmM\left(\frac{1}{R_1^2} - \frac{1}{R_2^2}\right)$  (2)  $GmM\left(\frac{1}{R_1} - \frac{1}{R_2}\right)$   
(3)  $2GmM\left(\frac{1}{R_1} - \frac{1}{R_2}\right)$  (4)  $\frac{1}{2}GmM\left(\frac{1}{R_1} - \frac{1}{R_2}\right)$

Ans. (4)

Sol. 
$$-\frac{GMm}{2R_1} + \text{KE} = -\frac{GMm}{2R_2}$$

$$\text{KE} = \frac{GMm}{2} \left[ \frac{1}{R_1} - \frac{1}{R_2} \right]$$

72. The speed of a projectile at its maximum height is half of its initial speed. The angle of projection is

- (1)  $60^\circ$  (2)  $15^\circ$   
(3)  $30^\circ$  (4)  $45^\circ$

Ans. (1)

Sol.  $v' = v_0 \cos \theta$

$$\frac{v_0}{2} = v_0 \cos \theta$$

$$\cos \theta = \frac{1}{2}$$

$$\theta = 60^\circ$$

73. From a circular disc of radius  $R$  and mass  $9M$ , a small disc of mass  $M$  and radius  $\frac{R}{3}$  is removed concentrically. The moment of inertia of the remaining disc about an axis perpendicular to the plane of the disc and passing through its centre is

- (1)  $\frac{40}{9}MR^2$  (2)  $MR^2$   
(3)  $4MR^2$  (4)  $\frac{4}{9}MR^2$

Ans. (1)

Sol.  $I = I_1 - I_2$

$$= \frac{9MR^2}{2} - \frac{MR^2}{18}$$

$$= \frac{81MR^2 - MR^2}{18}$$

$$= \frac{40MR^2}{9}$$

74. A particle moves in  $x$ - $y$  plane according to rule  $x = a \sin \omega t$  and  $y = a \cos \omega t$ . The particle follows

- (1) An elliptical path  
(2) A circular path  
(3) A parabolic path  
(4) A straight line path inclined equally to  $x$  and  $y$ -axes

Ans. (2)

Sol.  $\frac{x}{a} = \sin \omega t$

$$\frac{y}{a} = \cos \omega t$$

$$\frac{y^2}{a^2} + \frac{x^2}{a^2} = 1$$

$$y^2 + x^2 = a^2$$

75. A closely wound solenoid of 2000 turns and area of cross-section  $1.5 \times 10^{-4} \text{ m}^2$  carries a current of 2.0 A. It is suspended through its centre and perpendicular to its length, allowing it to turn in a horizontal plane in a uniform magnetic field  $5 \times 10^{-2}$  tesla making an angle of  $30^\circ$  with the axis of the solenoid. The torque on the solenoid will be
- (1)  $3 \times 10^{-3} \text{ N.m}$                       (2)  $1.5 \times 10^{-3} \text{ N.m}$   
(3)  $1.5 \times 10^{-2} \text{ N.m}$                       (4)  $3 \times 10^{-2} \text{ N.m}$

**Ans. (3)**

**Sol.**  $M = 2000 \times 1.5 \times 10^{-4} \times 2$

$$= 6 \times 10^{-1}$$

$$\tau = MB \sin 30$$

$$= 0.6 \times 5 \times 10^{-2} \times \frac{1}{2}$$

$$\tau = 1.5 \times 10^{-2} \text{ Nm}$$

76. The decay constant of a radio isotope is  $\lambda$ . If  $A_1$  and  $A_2$  are its activities at times  $t_1$  and  $t_2$  respectively, the number of nuclei which have decayed during the time  $(t_1 - t_2)$
- (1)  $A_1 t_1 - A_2 t_2$                       (2)  $A_1 - A_2$   
(3)  $(A_1 - A_2)/\lambda$                       (4)  $\lambda(A_1 - A_2)$

**Ans. (3)**

**Sol.**  $A_1 = \lambda N_1$

$$A_2 = \lambda N_2$$

$$N_1 - N_2 = \left[ \frac{A_1 - A_2}{\lambda} \right]$$

77. A particle having a mass of  $10^{-2} \text{ kg}$  carries a charge of  $5 \times 10^{-8} \text{ C}$ . The particle is given an initial horizontal velocity of  $10^5 \text{ ms}^{-1}$  in the presence of electric field  $\vec{E}$  and magnetic field  $\vec{B}$ . To keep the particle moving in a horizontal direction, it is necessary that
- (a)  $\vec{B}$  should be perpendicular to the direction of velocity and  $\vec{E}$  should be along the direction of velocity  
(b) Both  $\vec{B}$  and  $\vec{E}$  should be along the direction of velocity  
(c) Both  $\vec{B}$  and  $\vec{E}$  are mutually perpendicular and perpendicular to the direction of velocity  
(d)  $\vec{B}$  should be along the direction of velocity and  $\vec{E}$  should be perpendicular to the direction of velocity

Which one of the following pairs of statements is possible?

- (1) (a) and (c)                      (2) (c) and (d)  
(3) (b) and (c)                      (4) (b) and (d)

**Ans. (3)**

78. The binding energy per nucleon in deuterium and helium nuclei are 1.1 MeV and 7.0 MeV, respectively. When two deuterium nuclei fuse to form a helium nucleus the energy released in the fusion is

- (1) 23.6 MeV                      (2) 2.2 MeV  
(3) 28.0 MeV                      (4) 30.2 MeV

**Ans. (1)**

**Sol.**  $\Delta E = (28 - 4.4) \text{ MeV}$

$$\Delta E = 23.6 \text{ MeV}$$

79. The electron in the hydrogen atom jumps from excited state  $(n = 3)$  to its ground state  $(n = 1)$  and the photons thus emitted irradiate a photosensitive material. If the work function of the material is 5.1 eV, the stopping potential is estimated to be (the energy of the electron in  $n^{\text{th}}$  state

$$E_n = -\frac{13.6}{n^2} \text{ eV}$$

- (1) 5.1 V                      (2) 12.1 V  
(3) 17.2 V                      (4) 7 V

**Ans. (4)**

**Sol.**  $V = (12.1 - 5.1) \text{ volt}$

$$V_{\text{stopping}} = 7 \text{ V}$$

80. If  $c_p$  and  $c_v$  denote the specific heats (per unit mass) of an ideal gas of molecular weight  $M$
- (1)  $C_p - C_v = R/M^2$                       (2)  $C_p - C_v = R$   
(3)  $C_p - C_v = R/M$                       (4)  $C_p - C_v = MR$   
where  $R$  is the molar gas constant

**Ans. (3)**

**Sol.**  $C_p - C_v = R$

$$MC_p - MC_v = R$$

$$C_p - C_v = \frac{R}{M}$$

81. A condenser of capacity  $C$  is charged to a potential difference of  $V_1$ . The plates of the condenser are then connected to an ideal inductor of inductance  $L$ . The current through the inductor when the potential difference across the condenser reduces to  $V_2$  is

(1)  $\left( \frac{C(V_1 - V_2)^2}{L} \right)^{\frac{1}{2}}$                       (2)  $\frac{C(V_1^2 - V_2^2)}{L}$

(3)  $\frac{C(V_1^2 + V_2^2)}{L}$                       (4)  $\left( \frac{C(V_1^2 - V_2^2)}{L} \right)^{\frac{1}{2}}$

**Ans. (4)**



82. The dependence of acceleration due to gravity  $g$  on the distance  $r$  from the centre of the earth, assumed to be a sphere of radius  $R$  of uniform density is as shown in figures below

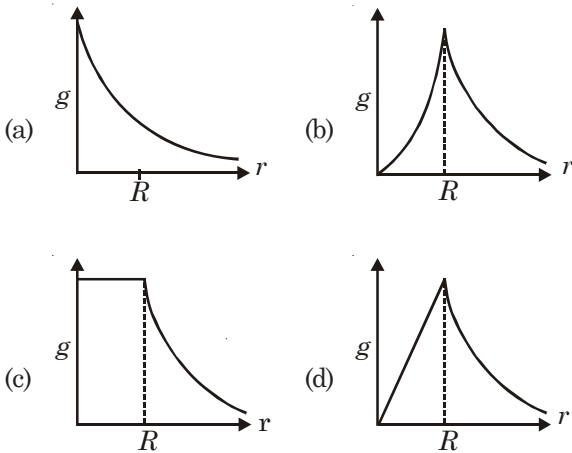

The correct figure is

- (1) (d)                      (2) (a)  
(3) (b)                      (4) (c)

**Ans. (1)**

83. A solid cylinder and a hollow cylinder, both of the same mass and same external diameter are released from the same height at the same time on a inclined plane. Both roll down without slipping. Which one will reach the bottom first?

- (1) Both together only when angle of inclination of plane is  $45^\circ$   
(2) Both together  
(3) Hollow cylinder  
(4) Solid cylinder

**Ans. (4)**

Sol.  $t = \sqrt{\frac{2\ell \left(1 + \frac{k^2}{R^2}\right)}{g \sin \theta}}$

$\ell$  = length of incline plane

84. The thermo e.m.f.  $E$  in volts of a certain thermo-couple is found to vary with temperature difference  $\theta$  in  $^\circ\text{C}$  between the two junctions according to the relation

$$E = 30\theta - \frac{\theta^2}{15}$$

The neutral temperature for the thermo-couple will be

- (1)  $450^\circ\text{C}$                       (2)  $400^\circ\text{C}$   
(3)  $225^\circ\text{C}$                       (4)  $30^\circ\text{C}$

**Ans. (3)**

Sol. At neutral temperature

$$\frac{dE}{d\theta} = 0$$

$$30 - \frac{2\theta}{15} = 0$$

$$\theta = 225^\circ\text{C}$$

85. (a) Centre of gravity (C.G.) of a body is the point at which the weight of the body acts  
(b) Centre of mass coincides with the centre of gravity if the earth is assumed to have infinitely large radius  
(c) To evaluate the gravitational field intensity due to any body at an external point, the entire mass of the body can be considered to be concentrated at its C.G.  
(d) The radius of gyration of any body rotating about an axis is the length of the perpendicular dropped from the C.G. of the body to the axis

Which one of the following pairs of statements is **correct**?

- (1) (d) and (a)                      (2) (a) and (b)  
(3) (b) and (c)                      (4) (c) and (d)

**Ans. (1)**

86. The magnetic moment of a diamagnetic atom is

- (1) Much greater than one  
(2) 1  
(3) Between zero and one  
(4) Equal to zero

**Ans. (4)**

87. Two identical bar magnets are fixed with their centres at a distance  $d$  apart. A stationary charge  $Q$  is placed at  $P$  in between the gap of the two magnets at a distance  $D$  from the centre  $O$  as shown in the figure

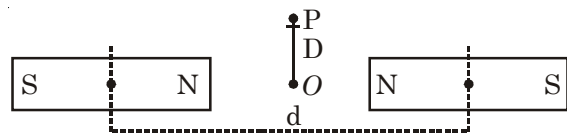

The force on the charge  $Q$  is

- (1) Zero  
(2) Directed along  $OP$   
(3) Directed along  $PO$   
(4) Directed perpendicular to the plane of paper

**Ans. (1)**

88. A particle of mass  $M$  starting from rest undergoes uniform acceleration. If the speed acquired in time  $T$  is  $V$ , the power delivered to the particle is

- (1)  $\frac{MV^2}{T}$  (2)  $\frac{1}{2} \frac{MV^2}{T^2}$   
(3)  $\frac{MV^2}{T^2}$  (4)  $\frac{1}{2} \frac{MV^2}{T}$

Ans. (4)

89. A thin circular ring of mass  $M$  and radius  $r$  is rotating about its axis with constant angular velocity  $\omega$ . Two objects each of mass  $m$  are attached gently to the opposite ends of a diameter of the ring. The ring now rotates with angular velocity given by

- (1)  $\frac{(M+2m)\omega}{2m}$  (2)  $\frac{2M\omega}{M+2m}$   
(3)  $\frac{(M+2m)\omega}{M}$  (4)  $\frac{M\omega}{M+2m}$

Ans. (4)

Sol.  $MR^2\omega = (M + 2m)R^2\omega'$

$$\omega' = \frac{m\omega}{(M+2m)}$$

90. A monoatomic gas at pressure  $P_1$  and  $V_1$  is compressed adiabatically to  $\frac{1}{8}$ th its original volume. What is the final pressure of the gas?

- (1)  $64 P_1$  (2)  $P_1$   
(3)  $16 P_1$  (4)  $32 P_1$

Ans. (4)

Sol.  $PV^{5/3} = P' \left(\frac{V}{8}\right)^{5/3}$

$$P' = P(8)^{5/3}$$

$$= P \times 2^5$$

$$P' = 32P$$

91. Among the elements Ca, Mg, P and Cl, the order of increasing atomic radii is

- (1)  $Mg < Ca < Cl < P$  (2)  $Cl < P < Mg < Ca$   
(3)  $P < Cl < Ca < Mg$  (4)  $Ca < Mg < P < Cl$

Ans. (2)

Sol. In a period size decreases from left to right.

92. The reaction

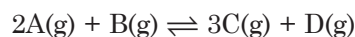

is begun with the concentrations of A and B both at an initial value of 1.00 M. When equilibrium is reached, the concentration of D is measured and found to be 0.25 M. The value for the equilibrium constant for this reaction is given by the expression

- (1)  $[(0.75)^3(0.25)] \div [(1.00)^2(1.00)]$   
(2)  $[(0.75)^3(0.25)] \div [(0.50)^2(0.75)]$   
(3)  $[(0.75)^3(0.25)] \div [(0.50)^2(0.25)]$   
(4)  $[(0.75)^3(0.25)] \div [(0.75)^2(0.25)]$

Ans. (2)

Sol.

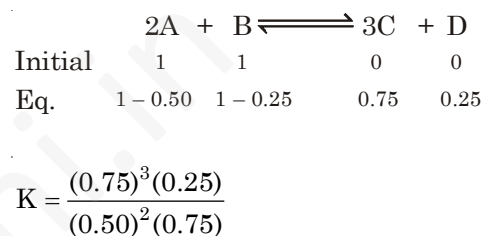

93. Which of the following expressions correctly represents the equivalent conductance at infinite dilution of  $Al_2(SO_4)_3$ . Given that  $\Lambda_{Al^{3+}}^{\circ}$  and  $\Lambda_{SO_4^{2-}}^{\circ}$  are the equivalent conductances at infinite dilution of the respective ions?

- (1)  $2\Lambda_{Al^{3+}}^{\circ} + 3\Lambda_{SO_4^{2-}}^{\circ}$  (2)  $\Lambda_{Al^{3+}}^{\circ} + \Lambda_{SO_4^{2-}}^{\circ}$   
(3)  $(\Lambda_{Al^{3+}}^{\circ} + \Lambda_{SO_4^{2-}}^{\circ}) \times 6$  (4)  $\frac{1}{3} \Lambda_{Al^{3+}}^{\circ} + \frac{1}{2} \Lambda_{SO_4^{2-}}^{\circ}$

Ans. (2)

Sol. As equivalent conductance are given for ions.

94. The pressure exerted by 6.0 g of methane gas in a 0.03 m<sup>3</sup> vessel at 129°C is (Atomic masses : C = 12.01, H = 1.01 and R = 8.314 JK<sup>-1</sup> mol<sup>-1</sup>)

- (1) 215216 Pa (2) 13409 Pa  
(3) 41648 Pa (4) 31684 Pa

Ans. (3)

Sol.  $PV = nRT$

$$P = \frac{6}{16.05} \times \frac{8.314 \times 402}{0.03} = 41648 \text{ Pa}$$

95. Match List-I (Equations) with List-II (Type of process) and select the correct option

List-I Equations	List-II Type of processes
a. $K_p > Q$	(i) Non-spontaneous
b. $\Delta G^\circ < RT \ln Q$	(ii) Equilibrium
c. $K_p = Q$	(iii) Spontaneous and endothermic
d. $T > \frac{\Delta H}{\Delta S}$	(iv) Spontaneous

- (1) a(i), b(ii), c(iii), d(iv) (2) a(iii), b(iv), c(ii), d(i)  
(3) a(iv), b(i), c(ii), d(iii) (4) a(ii), b(i), c(iv), d(iii)

**Ans. (3)**

**Sol.**  $K_p > Q \rightarrow$  Reaction moves in forward direction.

$\Delta G < RT \ln Q$ ,  $\Delta G = +ve =$  reaction non-spontaneous

$K_p = Q =$  Reaction is equilibrium

$T > \frac{\Delta H}{\Delta S} = \Delta H = +ve$ , endothermic

Thus,  $\Delta H < T\Delta S$  spontaneous

96. Among the following four compounds

- |                    |                    |
|--------------------|--------------------|
| a. Phenol          | b. Methyl phenol   |
| c. Metanitrophenol | d. Paranitrophenol |

The acidity order is

- (1)  $d > c > a > b$  (2)  $c > d > a > b$   
(3)  $a > d > c > b$  (4)  $b > a > c > d$

**Ans. (1)**

**Sol.** Withdrawing group increasing the acidic character and electron donating group decreases the acidic characters.

97. Among the following which one has the highest cation to anion size ratio?

- |         |         |
|---------|---------|
| (1) CsI | (2) CsF |
| (3) LiF | (4) NaF |

**Ans. (2)**

**Sol.**  $Cs^+ > Li^+ \rightarrow$  atomic radii

$I^- > F^- \rightarrow$  atomic radii

$\therefore$  CsF has highest cation to anion size ratio

98. Three moles of an ideal gas expanded spontaneously into vacuum. The work done will be

- |              |              |
|--------------|--------------|
| (1) Infinite | (2) 3 Joules |
| (3) 9 Joules | (4) Zero     |

**Ans. (4)**

**Sol.** In vacuum,  $P_{ext} = 0$

$$W = 0$$

99. Which of the following species is not electrophilic in nature?

- |                   |                   |
|-------------------|-------------------|
| (1) $Cl^\oplus$   | (2) $BH_3$        |
| (3) $H_3O^\oplus$ | (4) $NO_2^\oplus$ |

**Ans. (3)**

**Sol.**  $Cl^+$ ,  $BH_3$ ,  $NO_2^\oplus$  are electron deficient.

100. A 0.66 kg ball is moving with a speed of 100 m/s. The associated wavelength will be

$$(h = 6.6 \times 10^{-34} \text{ Js})$$

- |                                     |                                     |
|-------------------------------------|-------------------------------------|
| (1) $6.6 \times 10^{-32} \text{ m}$ | (2) $6.6 \times 10^{-34} \text{ m}$ |
| (3) $1.0 \times 10^{-35} \text{ m}$ | (4) $1.0 \times 10^{-32} \text{ m}$ |

**Ans. (3)**

**Sol.**  $\lambda = \frac{h}{mv}$

$$= \frac{6.6 \times 10^{-34}}{0.66 \times 100} = 10^{-35} \text{ m}$$

101. Consider the following relations for emf of a electrochemical cell

- (a) emf of cell = (Oxidation potential of anode) – (Reduction potential of cathode)  
(b) emf of cell = (Oxidation potential of anode) + (Reduction potential of cathode)  
(c) emf of cell = (Reductional potential of anode) + (Reduction potential of cathode)  
(d) emf of cell = (Oxidation potential of anode) – (Oxidation potential of cathode)

Which of the above relations are correct?

**Options:**

- |                 |                 |
|-----------------|-----------------|
| (1) (c) and (a) | (2) (a) and (b) |
| (3) (c) and (d) | (4) (b) and (d) |

**Ans. (4)**

**Sol.**  $E_{cell} = E_{cathode}^\circ - E_{Anode}^\circ$   
(Red) (Red)

or

$E_{cell} = E_{cathode}^\circ - E_{Anode}^\circ$   
(Red) (oxid)

or

$E_{cell} = E_{Anode}^\circ - E_{cathode}^\circ$   
(oxid) (oxid)

102. In which of the following molecules the central atom does not have  $sp^3$  hybridization?

- (1)  $CH_4$  (2)  $SF_4$   
(3)  $BF_4^-$  (4)  $NH_4^+$

Ans. (2)

Sol.  $SF_4 = sp^3d$

103. For vaporization of water at 1 atmospheric pressure, the values of  $\Delta H$  and  $\Delta S$  are  $40.63 \text{ kJ mol}^{-1}$  and  $108.8 \text{ JK}^{-1} \text{ mol}^{-1}$ , respectively. The temperature when Gibbs energy change ( $\Delta G$ ) for this transformation will be zero, is

- (1) 273.4 K (2) 393.4 K  
(3) 373.4 K (4) 293.4 K

Ans. (3)

Sol.  $\Delta G = \Delta H - T\Delta S$

$$\Delta G = 0$$

$$\Delta H = T\Delta S,$$

$$T = \frac{40.63 \times 10^3}{108.8} = 373.4 \text{ K}$$

104. Match List-I (substances) with List-II (process) employed in the manufacture of the substances and select the correct option

List-I Substances	List-II Processes
a. Sulphuric acid	(i) Haber's Process
b. Steel	(ii) Bessemer's Process
c. Sodium hydroxide	(iii) Leblanc Process
d. Ammonia	(iv) Contact Process
(1) a(i), b(iv), c(ii), d(iii)	(2) a(i), b(ii), c(iii), d(iv)
(3) a(iv), b(iii), c(ii), d(i)	(4) a(iv), b(ii), c(iii), d(i)

Ans. (4)

Sol. Fact.

105. When glycerol is treated with excess of HI, it produces

- (1) 2-iodopropane (2) Allyl iodide  
(3) Propene (4) Glycerol triiodide

Ans. (1)

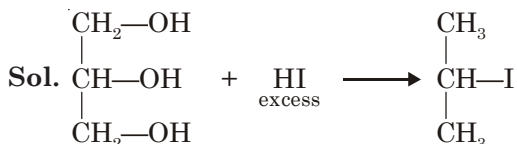

106. Some statements about heavy water are given below

- a. Heavy water is used as a moderator in nuclear reactors  
b. Heavy water is more associated than ordinary water  
c. Heavy water is more effective solvent than ordinary water

Which of the above statements are correct?

- (1) a and b (2) a, b and c  
(3) b and c (4) a and c

Ans. (1)

Sol. Dielectric constant of  $H_2O > D_2O$ . Therefore,  $H_2O$  is more effective solvent.

B.P. of  $D_2O > B.P.$  of  $H_2O$ .

107. The compound A on heating gives a colourless gas and a residue that is dissolved in water to obtain B. Excess of  $CO_2$  is bubbled through aqueous solution of B, C is formed which is recovered in the solid form. Solid C on gentle heating gives back A. The compound is

- (1)  $CaCO_3$  (2)  $Na_2CO_3$   
(3)  $K_2CO_3$  (4)  $CaSO_4 \cdot 2H_2O$

Ans. (1)

Sol.  $A \rightarrow CaCO_3$

$B \rightarrow Ca(OH)_2$

$C \rightarrow Ca(HCO_3)_2$

108. Match the compounds given in List-I with their characteristic reactions given in List-II. Select the correct option

List-I (Compounds)	List-II (Reactions)
a. $CH_3CH_2CH_2CH_2NH_2$	(i) Alkaline hydrolysis
b. $CH_3C \equiv CH$	(ii) With KOH (alcohol) and $CHCl_3$ produces bad smell
c. $CH_3CH_2COOCH_3$	(iii) Gives white ppt. with ammoniacal $AgNO_3$
d. $CH_3CH(OH)CH_3$	(iv) With Lucas reagent cloudiness appears after 5 minutes

- (1) a(ii), b(i), c(iv), d(iii)  
(2) a(iii), b(ii), c(i), d(iv)  
(3) a(ii), b(iii), c(i), d(iv)  
(4) a(iv), b(ii), c(iii), d(i)

Ans. (3)

Sol. Fact.

109. Which one of the following compounds will be most readily dehydrated?

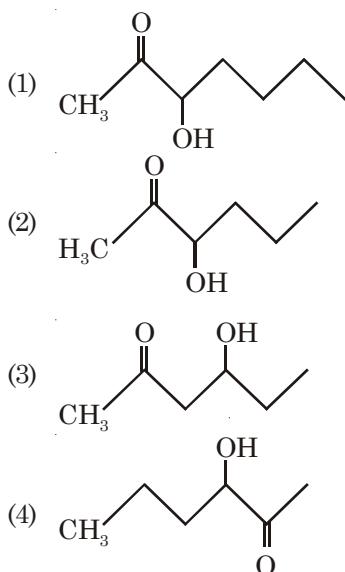

Ans. (3)

Sol. As carbocation intermediate, more the stability of carbocation, faster the rate of dehydration.

110. The rate of the reaction

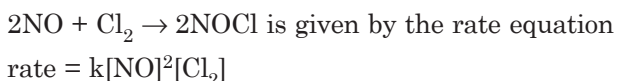

The value of the rate constant can be increased by

- (1) Increasing the temperature
- (2) Increasing the concentration of NO
- (3) Increasing the concentration of the  $\text{Cl}_2$
- (4) Doing all of these

Ans. (1)

Sol. Concentration do not affect rate constant.

111. Which one of the following complexes is **not** expected to exhibit isomerism?

- (1)  $[\text{Ni}(\text{NH}_3)_4(\text{H}_2\text{O})_2]^{2+}$
- (2)  $[\text{Pt}(\text{NH}_3)_2\text{Cl}_2]$
- (3)  $[\text{Ni}(\text{NH}_3)_2\text{Cl}_2]$
- (4)  $[\text{Ni}(\text{en})_3]^{2+}$

Ans. (3)

112. Which of the following conformers for ethylene glycol is most stable?

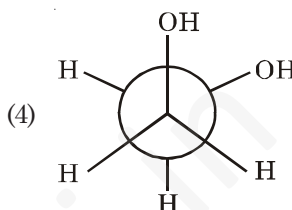
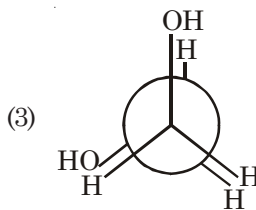
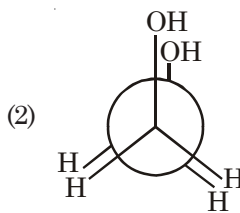
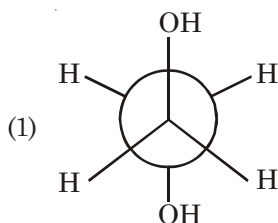

Ans. (4)

Sol. Intramolecular H-bonding.

113. The IUPAC name of the compound  $\text{CH}_3\text{CH}=\text{CHC}\equiv\text{CH}$  is

- (1) Pent-4-yn-2-ene
- (2) Pent-3-en-1-yne
- (3) Pent-2-en-4-yne
- (4) Pent-1-yn-3-ene

Ans. (2)

Sol. Fact.

114. Which of the following oxidation states is the most common among the lanthanoids?

- (1) 4
- (2) 2
- (3) 5
- (4) 3

Ans. (4)

Sol. Fact

115. How many bridging oxygen atoms are present in  $\text{P}_4\text{O}_{10}$ ?

- (1) 6
- (2) 4
- (3) 2
- (4) 5

Ans. (1)

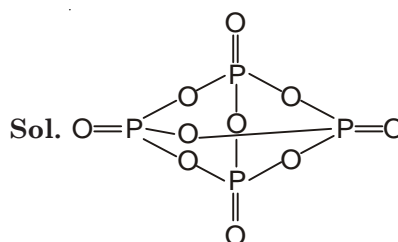

(18)



116. Some of the properties of the two species,  $\text{NO}_3^-$  and  $\text{H}_3\text{O}^+$  are described below. Which one of them is correct?

- (1) Dissimilar in hybridization for the central atom with different structures
- (2) Isostructural with same hybridization for the central atom
- (3) Isostructural with different hybridization for the central atom
- (4) Similar in hybridization for the central atom with different structures

Ans. (1)

Sol.  $\text{NO}_3^- = sp^2$

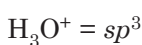

117. The following two reactions are known :

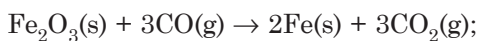

$$\Delta H = -26.8 \text{ kJ}$$

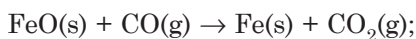

$$\Delta H = -16.5 \text{ kJ}$$

The value of  $\Delta H$  for the following reaction

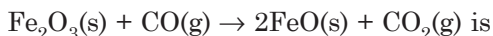

- (1) +10.3 kJ
- (2) -43.3 kJ
- (3) -10.3 kJ
- (4) +6.2 kJ

Ans. (4)

Sol. (1) - 2(2)

$$\begin{aligned} \text{i.e. } & -26.8 - (2)(-16.5) \\ & = 6.2 \text{ kJ} \end{aligned}$$

118. Following compounds are given

- a.  $\text{CH}_3\text{CH}_2\text{OH}$
- b.  $\text{CH}_3\text{COCH}_3$
- c.  $\begin{array}{c} \text{CH}_3-\text{CHOH} \\ | \\ \text{CH}_3 \end{array}$
- d.  $\text{CH}_3\text{OH}$

Which of the above compound(s), on being warmed with iodine solution and NaOH, will give iodoform?

- (1) a, c and d
- (2) Only b
- (3) a, b and c
- (4) a and b

Ans. (3)

Sol. Terminal  $\text{CH}_3-\overset{\text{O}}{\parallel}{\text{C}}-$  or  $\text{CH}_3-\overset{\text{OH}}{\underset{\text{H}}{\text{C}}}-$  show positive

iodoform test.

119. Fructose reduces Tollen's reagent due to

- (1) Asymmetric carbons
- (2) Primary alcoholic group
- (3) Secondary alcoholic group
- (4) Enolisation of fructose followed by conversion to aldehyde by base

Ans. (4)

Sol. Fact.

120. In the following reaction

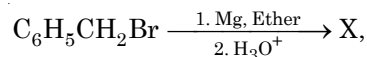

the product 'X' is

- (1)  $\text{C}_6\text{H}_5\text{CH}_2\text{OCH}_2\text{C}_6\text{H}_5$
- (2)  $\text{C}_6\text{H}_5\text{CH}_2\text{OH}$
- (3)  $\text{C}_6\text{H}_5\text{CH}_3$
- (4)  $\text{C}_6\text{H}_5\text{CH}_2\text{CH}_2\text{C}_6\text{H}_5$

Ans. (3)

