

**Sample PAPER – 2013**  
**Sub :PHYSICS (THEORY)**

**Class XII**

Maximum Marks: 70

Duration: 3 hours

**General Instructions:**

- (a) All questions are compulsory.  
 (b) There are 30 questions in total. Questions 1 to 8 carry 1 mark each, questions 9 to 18 carry 2 marks each, questions 19 to 27 carry 3 marks each and questions 28 to 30 carry 5 marks each.  
 (c) There is no overall choice. However, an internal choice has been provided in one question of 2 marks, one question of 3 marks and all three questions of 5 marks. You have to attempt only one of the given choices in such questions.  
 (d) Use of calculators is not permitted.  
 (e) You may use the following physical constants where ever necessary:  
 $c = 3 \times 10^8 \text{ ms}^{-1}$   
 $h = 6.6 \times 10^{-34} \text{ Js}$   
 $e = 1.6 \times 10^{-19} \text{ C}$   
 $\mu_0 = 4\pi \times 10^{-7} \text{ TmA}^{-1}$   
 Boltzmann's constant  $k = 1.38 \times 10^{-23} \text{ JK}^{-1}$   
 Avogadro's number  $N_A = 6.023 \times 10^{23} / \text{mole}$   
 Mass of neutron  $m_n = 1.6 \times 10^{-27} \text{ kg}$   
 Mass of electron  $m_e = 9 \times 10^{-31} \text{ kg}$

- A proton is moving along +ve x-axis in the presence of uniform magnetic field along +ve y-axis. What is the direction of force acting on it?
- How does the (a) pole strength and (b) magnetic moment of each part of a bar magnet change if it is cut into two equal pieces along its length?
- What is the polarizing angle of a medium of refractive index 1.732?
- Give the ratios of the velocities of two light waves travelling in vacuum and having wavelengths  $4000\text{\AA}$  and  $8000\text{\AA}$ .
- Two metals A and B have work functions 4 eV and 10 eV respectively. Which metal has higher threshold wavelength?
- State the reason, why GaAs is most commonly used in making of a solar cell.
- In which direction would a compass needle align if taken to geographic (a) north, and (b) south pole?
- The following truth table gives the output of a 2-input logic gate: If the output of this gate is fed as input of a NOT gate, name the new logic gate so formed.

A	B	Output
0	0	1
0	1	0
1	0	0
1	1	0

- Red light is incident on a thin converging lens of focal length  $f$ . Briefly explain how the focal length of the lens will change, if red light is replaced with blue light.

- 10.** Two parallel coaxial circular coils of equal radius 'R' and equal number of turns 'N', carry equal current 'I' in the same direction and are separated by a distance '2R'. Find the magnitude and direction of the net magnetic field produced at the mid-point of the line joining their centers.
- 11.** A metallic rod of length  $l$  is rotated at a constant angular speed  $\omega$ , normal to a uniform magnetic field  $B$ . Derive an expression for the current induced in the rod, if the resistance of the rod is  $R$ .
- 12.** A parallel plate capacitor is to be designed with a voltage rating 1 kV using a material of dielectric constant 3 and dielectric strength about  $10^7 \text{ Vm}^{-1}$ . For safety we would like the field never to exceed say, 10% of the dielectric strength. What minimum area of the plates is required to have a capacitance of 50 pF?
- 13.** Name the following constituent radiations of electromagnetic spectrum which  
(i) produce intense heating effect.  
(ii) is absorbed by the ozone layer in the atmosphere.  
(iii) is used for studying crystal structure.  
Write one more application for each of these radiations.
- 14.** When a monochromatic yellow colored light beam is incident on a given photosensitive surface, photo electrons are not ejected, while the same surface gives photo electrons when exposed to green colored monochromatic beam. What will happen if the same photosensitive surface is exposed to (i) violet and (ii) red colored, monochromatic beam of light? Justify your answer.
- 15.** Two heater wires of the same dimensions are first connected in series and then in parallel to a source of supply. What will be the ratio of heat produced in the two cases?
- 16.** A cylindrical metallic wire is stretched to increase its length by 5%. Calculate the percentage change in its resistance.
- Or** Write the mathematical relation between mobility and drift velocity of charge carriers in a conductor. Name the mobile charge carriers responsible for conduction of electric current in (i) an electrolyte (ii) an ionized gas.
- 17.** Draw a block diagram of a simple amplitude modulation. Explain briefly how amplitude modulation is achieved.
- 18.** Two radioactive nuclei X and Y initially contain an equal number of atoms. Their half life is 1 hour and 2 hours respectively. Calculate the ratio of their rates of disintegration after two hours.
- 19.** Draw and explain the output waveform across the load resistor  $R$ , if the input waveform is as shown in the given figure.

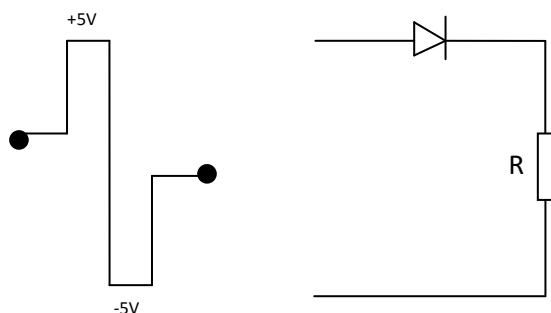

- 20.** What are coherent sources? Why are coherent sources required to produce interference of light? Give an example of interference of light in everyday life. In Young's double slit experiment, the two slits are 0.03 cm apart and the screen is placed at a distance of 1.5m away from the slits. The distance between the central bright fringe and fourth bright fringe is 1cm. Calculate the wavelength of light used.
- Or** What is interference of light? Write two essential conditions for sustained interference pattern

to be produced on the screen.

Draw a graph showing the variation of intensity versus the position on the screen in Young's experiment when (a) both the slits are opened and (b) one of the slits is closed. What is the effect on the interference pattern in Young's double slit experiment when (i) screen is moved closer to the plane of slits, (ii) separation between two slits is increased. Explain your answer in each case.

**21.** Using Biot-Savart's law, derive the expression for magnetic field due to current carrying circular coil, at a point along the axis of the coil.

**22.** Derive an expression for the self-inductance of a long solenoid. An inductor  $L$ , a capacitor  $20 \mu\text{F}$ , a resistor  $10 \Omega$  is connected in series with an ac source of frequency  $50 \text{ Hz}$ . If the current is in phase with the voltage, calculate the inductance if the inductor.

**23.** Find the equivalent capacitance of the combination of capacitors between the points A and B as shown. Also calculate the total charge that flows in the circuit when a  $100 \text{ V}$  battery is connected between the points A and B.

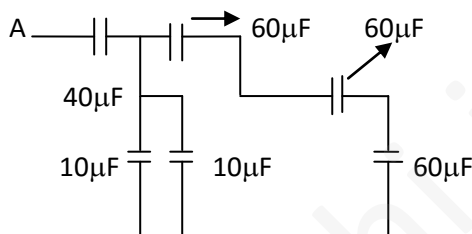

**24.** The oscillating magnetic field in a plane electromagnetic wave is given by

$$B_y = (8 \times 10^{-6}) \sin [2 \times 10^{11}t + 300\pi x] \text{ V m}^{-1}$$

(a) Obtain the value of the wavelength of the electromagnetic wave.

(b) Write down the expression for the oscillating electric field.

**25.** Define the term 'threshold frequency' for photoelectric effect. Show graphically how stopping potential for a given metal varies with frequency of incident radiation. What does the slope of this graph represent?

**26.** Using the mathematical expression for the conductivity of a material, explain how it varies with temperature for (i) semiconductors, (ii) good conductors. A heating element using nichrome connected to a  $230 \text{ V}$  supply draws an initial current of  $3.2 \text{ A}$  which settles after a few seconds at a steady value of  $2.8 \text{ A}$ . What is the steady temperature of the heating element, if the room temperature is  $27^\circ\text{C}$ ? Temperature coefficient of resistance of nichrome averaged over the temperature range involved is  $1.7 \times 10^{-4} \text{ }^\circ\text{C}^{-1}$ .

**27.** A TV transmission tower at a particular station has a height of  $160 \text{ m}$ .

(i) What is its coverage range ?

(ii) What is the population covered by the transmission if the average population density around the tower is  $1200 \text{ km}^{-2}$ ?

(iii) By how much should the height of the tower be increased to double its coverage range?

(Radius of Earth =  $6400 \text{ km}$ ).

**28.** (a) Derive the relation connecting decay constant and half-life of a radioactive sample.

(b) How many disintegrations per second will occur in one gram of  ${}^{238}_{92}\text{U}$ , if its half-life against alpha decay is  $1.42 \times 10^{17} \text{ s}$ ?

**Or** Derive the expression for the radius of the ground state orbit of hydrogen atom, using Bohr's postulates. Calculate the frequency of the photon, which can excite the electron to  $-3.4 \text{ eV}$  from  $-13.67 \text{ eV}$ .

29. A schematic arrangement for transmitting a message signal (20 Hz to 20 kHz) is given below :

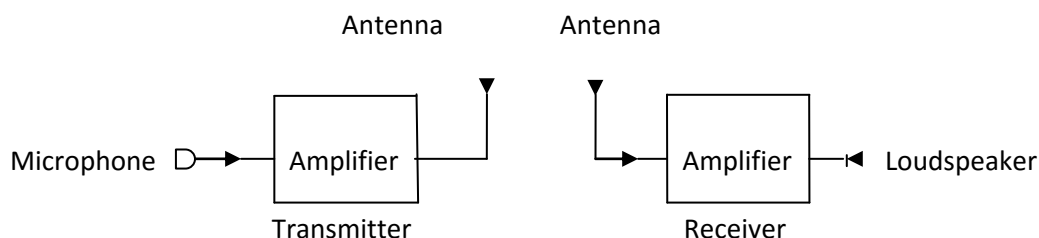

Give two drawbacks from which the arrangement suffers.

Describe briefly with the help of a block diagram the alternative arrangement for the transmission and reception of the message signal.

**Or** State the condition under which the phenomenon of diffraction of light takes place. Derive an expression for the width of the central maximum due to diffraction of light at a single slit. A slit of width ' $a$ ' is illuminated by a monochromatic light of wavelength 700nm at normal incidence. Calculate the value of ' $a$ ' for position of

- (i) first minimum at an angle of diffraction of  $30^\circ$ .
- (ii) first maximum at an angle of diffraction of  $30^\circ$ .

**30.** (a) What is plane polarized light? Two polaroids are placed at  $90^\circ$  to each other and the transmitted intensity is zero. What happens when one more polaroid is placed between these two, bisecting the angle between them? How will the intensity of transmitted light vary on further rotating the third polaroid?

(b) If a light beam shows no intensity variation when transmitted through a Polaroid which is rotated, does it mean that the light is unpolarized? Explain briefly.

**Or** A 20V battery of internal resistance  $1\Omega$  is connected to three coils of  $12\Omega$ ,  $6\Omega$  and  $4\Omega$  in parallel, a resistor of  $5\Omega$  and a reversed battery (emf 8V and internal resistance  $2\Omega$ ) as shown. Calculate :

- (i) the current in the circuit, (ii) current in resistor of  $12\Omega$  coil, and (iii) p.d. across each battery.

