

JEE MAIN 2014 Solution Physics (CODE- G)

31) When a rubber-band is stretched by a distance x , it exerts a restoring force of magnitude $F = ax + bx^2$ where a and b are constants. The work done in stretching the un stretched rubber-band by l is :

Sol. Work done in stretching the un stretched rubber-band by l is

$$W = \int_0^L F \cdot dx$$

$$\int_0^L (ax + bx^2) dx = \frac{9L^2}{2} + \frac{bL^3}{3}$$

Ans. 31-(4)

32) The coactivity of a small magnet where the ferromagnet gets demagnetized is $3 \times 10^3 \text{ A m}^{-1}$. The current required to be passed in a solenoid of length 10 cm and number of turns 100, so that the magnet gets demagnetized when inside the solenoid, is :

Sol. Coactivity of small magnet, where the ferromagnetic gets ferromagnetized is

$$H = 3 \times 10^3 \text{ Am}^{-1}$$

No. of turns, $n=100$. Magnet placed in a solenoid, of length, $l=10\text{cm} = \frac{1}{10} \text{ m}$. For demagnetization

$$\mu_0 H = \frac{\mu_0 n I}{l}$$

$$I = \frac{Hl}{n} = \frac{3 \times 10^3 \times 1}{100 \times 10} = 3 \text{ Anp}$$

32 - c4

33) In a large building, there are 15 bulbs of 40 w, 5 bulbs of 100 w, 5 fans of 80 w and 1 heater of 1 kW. The voltage of the electric mains is 220 V. The minimum capacity of the main fuse of the building will be :

Sol. Connection found in house is parallel combination.

$$I_{min} = \frac{V_{rated}}{R} \cdot \frac{1}{R} = \frac{1}{R_{40w \text{ bw}}} + \frac{1}{R_{100w}} + \frac{1}{R_{80}} + \frac{1}{R_1}$$

$$= \frac{P_1}{V^2} + \frac{P_2}{V^2} + \frac{P_3}{V^2} + \frac{P_4}{V^2}$$

$$= \frac{T}{V^2} (p_1 + p_2 + p_3 + p_4)$$

$$\begin{aligned}
 &= \frac{15 \times 40 + 5 \times 100 + 5 \times 80 + 1000 \times 1}{220 \times 220} \\
 \frac{1}{R} &= \frac{600 + 500 + 400 + 100}{220 \times 220} = \frac{1500}{(220)^2} \\
 R &= \frac{(220)^2 \Omega}{2500} \\
 = I_{min} &= \frac{V_{rated}}{R} = \frac{220 \times 2500}{(220)^2 \times 220} \\
 &= 12 \text{ amp}
 \end{aligned}$$

Hence, (33) → 4

34) An open glass tube is immersed in mercury in such a way that a length of 8 cm extends above the mercury level. The open end of the tube is then closed and sealed and the tube is raised vertically up by additional 46 cm. What will be length of the air column above mercury in the tube now?

(Atmospheric pressure = 76 cm of Hg)

Sol. Mercury in a column, tube contain a height of $-h = 8 \text{ cm}$

Assuming temperature to be constant boyle's law

Let y be the height. Raised in the in column $P_1 V_1 = P_2 V_2$

$$pg(76)(A \cdot 8) = pg(76 - (5u - y))(A \cdot y)$$

$$8 \times 76 = 76 - 54 + y$$

$$y = 16 \text{ cm}$$

$$(34) - B_2$$

35. A bob of mass m attached to an inextensible string of length l is suspended from a vertical support. The bob rotates in a horizontal circle with an angular speed ω rad/s about the vertical. About the point of suspension :

Sol. Bob attached to an inextensible string of length l is suspended rustically

Angular momentum, $L = m(\vec{r} \times \vec{v})$ direction is changing continuous towards O during horizontal motion, but its magnitude, $L = m\vec{r}\vec{v} \sin\theta = \text{constant}$

Angular momentums will not conscience due to torque generated by tinsion in the string

$$\frac{dL}{dt} = 0 \neq 0$$

Hence, 35 → 4

36. The current voltage relation of diode is given by $I = (e^{\frac{1000}{T}V} - 1)$ mA, where the applied voltage V is in volts and the temperature T is in degree Kelvin. If a student makes an error measuring ± 0.01 V while measuring the current of 5mA at 300 K, what will be the error in the value of current in mA ?

Sol. $I = (e^{1000v/t} - 1)ma$

Error in the value of current, error in $\Delta v = \pm 0.01V$ error I will be

$$\Delta I = e^{1000\frac{V}{T}} \frac{1000}{T} \Delta V \text{ or } \Delta I = (I + 1) \frac{1000}{T} \Delta V$$

On substituting the value, we get

$$\Delta I = (5 + 1) \frac{1000}{300} \times 0.01$$

$$\Delta I = 2 \times 10^{-1}mA$$

$$\Delta I = 0.2mA$$

Hence, (36) \rightarrow 2

- 37) From a tower of height H, a particle is thrown vertically upwards with a speed u. The time taken by the particle, to hit the ground, is n times that taken by it to reach the highest point of its path. The relation between H, u and n is :

Sol. Initial velocity = μ

Time taken to reach at top,

$$V = u - gt$$

$$0 = u - gt \Rightarrow t_1 = \frac{u}{g} \dots(i)$$

Now, time taken from top to bottom. Lets say t_2 ,

[figure]

To calculate, x

$$x = \frac{v^2 - u^2}{2g} \quad (v = 0)$$

$$\text{Or } x = \frac{u^2}{2g}$$

And,

So total height

$$x + H = \frac{1}{2} gt_2^2$$

$$\Rightarrow \frac{u^2}{2g} + H = \frac{1}{2} gt_2^2$$

$$\Rightarrow \frac{u^2}{g} + 2H = gt_2^2$$

$$t_2^2 = \sqrt{\frac{u^2}{g^2} + \frac{2H}{g}}$$

Total time taken, $T = t_1 + t_2$

$$T = \frac{u}{g} + \sqrt{\frac{u^2}{g^2} + \frac{2H}{g}}$$

Since, We are given,

$$T = nt_1$$

$$\Rightarrow \frac{u}{g} + \sqrt{\frac{u^2}{g^2} + \frac{2H}{g}} = \frac{nu}{g}$$

$$\Rightarrow \sqrt{\frac{u^2}{g^2} + \frac{2H}{g}} = \frac{(n-1)u}{g}$$

Squaring and solving, he get ve get

$$2gH = nu^2 (n - 2)$$

Hence, $37 \rightarrow 4$

38) A thin convex lens made from crown glass ($\mu = \frac{3}{2}$) has focal length f . When it is measured in two different liquids having refractive indices $\frac{4}{3}$ and $\frac{5}{3}$ it has the focal length f_1 and f_2 respectively. The correct relation between the focal lengths is :

Sol. μ convex lens = $\frac{3}{2}$ and focal length, f liquid -1, $\mu_{L1} = \frac{4}{3} < \mu$ convex lens

Liquid-2, $\mu_{L2} \Rightarrow \mu$ convex lens. Since focal length $\frac{1}{f} = (\mu - 1) \left(\frac{1}{R_1} - \frac{1}{R_2} \right) = \frac{1}{f} = \left(\frac{\mu_{lence}}{\mu_{medium}} - 1 \right) \left(\frac{1}{R_1} - \frac{1}{R_2} \right)$
 $\frac{1}{R_2} \mu_{L2} > \mu_{conalen} > \mu_{L1} f, > f f_2$ will become negative

$$\text{as } \frac{1}{f_2} = \left(\frac{3/2}{5/3} - 1 \right) \left(\frac{1}{R_1} - \frac{1}{R_2} \right) \frac{1}{f_2} < 0$$

Hence $38 \rightarrow 3$

39) A parallel plate capacitor is made of two circular plates separated by a distance of 5mm and with a dielectric of dielectric constant 2.2 between them. When the electric field in the dielectric is $3 \times 10^4 V/m$ the charge density of the positive plate will be close to :

Sol: Parallel plate capacitor, $d = 5mm$

$$K = 2.2$$

$$\frac{E_0}{K} = 3 \times 10^4 V/m$$

$$\text{Charge density, } = \frac{\sigma}{E_0} = E_0 = EK$$

$$\sigma = \frac{E}{\epsilon_0}$$

$$\sigma = 3 \times 10^4 \times 2 \cdot 2 \times 8 \cdot 85 \times 10^{-11}$$

Hence, (39) $\rightarrow 2$

- 40) In the circuit shown here, the point 'C' is kept connected to point 'A' till the current flowing through the circuit becomes constant. Afterward, suddenly, point 'C' is disconnected from point 'A' and connected to point 'B' at time $t=0$. Ratio of the voltage across resistance and the inductor at $t=L/R$ will be equal to :

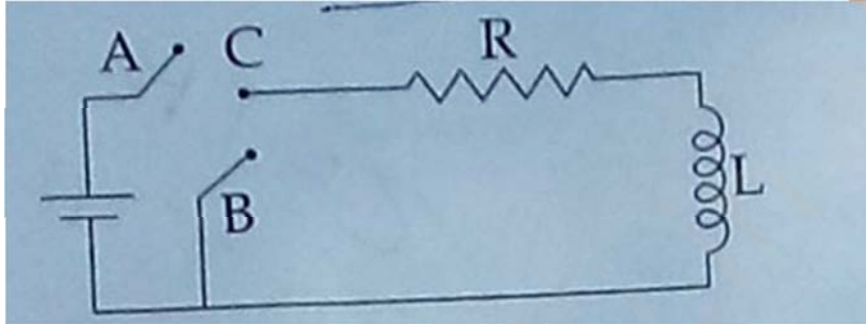

Sol. In (R-L) circuit, inductor would be charged first and then discharged later through resistance, R.

We are required to find the ratio of voltage across resistor to inductor at $t = \frac{L}{R} = \frac{V_R}{V_L} = \frac{IR}{L \frac{dI}{dt}} =$

$\frac{V(1-e^{-t/\tau})}{-V(1-e^{-t/\tau})} = -1$ voltage across inductor will be the source for discharging inductor across

resistor so. At, $t = \frac{L}{R}$,

$V_L = -L \frac{dI}{dt} = -L \frac{d}{dt}(I - e^{-t/\tau})$ and, $V_R = V_2 = \frac{V}{R} e^{-t/\tau}$ dividing above two equation we get

$$\frac{V_R}{V_L} = -1$$

$$40 \rightarrow 4$$

41. Two beams, A and B, of plane polarized light with mutually perpendicular planes of polarization are seen through a Polaroid. From the position when the beam A has maximum intensity (and beam B has zero intensity), a rotation of Polaroid through 30° makes the two beams appear equally bright. If the initial intensities of the two beams are I_A and I_B

Respectively, then $\frac{I_A}{I_B}$ equals:

Sol. 'A' and 'B'

Two beam of plane polarized light

From the position 'A' has, max intensity, 'B' would have 'O' intensity

Law of Malus,

Which polarized rotate by 30° ?

$$I_A \cos^2 30^\circ = I_B \cos^2 60^\circ$$

$$\frac{I_A}{I_B} = 1/3$$

Hence, 41 \rightarrow 1

42. There is a circular tube in a vertical plane. Two liquids which do not mix and of densities d_1 and d_2 are filled in the tube. Each liquid subtends 90° angle at centre. Radius joining their interface makes an angle α with vertical. Ratio $\frac{d_1}{d_2}$ is :

Sol. Net force at the mean position would

Balance, i.e.

$$F_1 = F_2$$

$$\text{For } f_1 = f_2$$

$$P_1 = P_2$$

$$(R \cos \alpha - R \sin \alpha) d_1 g = (R \sin \alpha + R \cos \alpha) d_2 g + (R - R \cos \alpha) d_1 g$$

$$\Rightarrow \frac{d_1}{d_2} = \frac{R \sin \alpha + R \cos \alpha}{R \cos \alpha - R \sin \alpha}$$

$$\frac{d_1}{d_2} = \frac{1 + \tan \alpha}{1 - \tan \alpha}$$

(Here writing the equation of force at mean position due to part of liquids)

Hence, 42 -4

43. The pressure that has to be applied to the ends of a steel wire of length 10 cm to keep its length constant when its temperature is raised by 100°C is :

(For steel Young's modulus is $2 \times 10^{11} \text{ N m}^{-2}$ and coefficient of thermal expansion is $1.1 \times 10^{-5} \text{ K}^{-1}$)

Sol. Presses applied $P = \frac{F}{A}$

$$\text{Young's modulus } Y = \frac{\text{stress}}{\text{strain}} = \frac{F/4}{\Delta l/l}$$

$$\Rightarrow \frac{F}{A} = Y \frac{\Delta l}{l} \quad \dots(i)$$

Since, $\Delta l = l_0 \alpha \Delta T$

$$\frac{\Delta l}{l} = \alpha \Delta T \quad (\Delta T = 100^\circ \text{C})$$

$$= 1.1 \times 10^{-5} \times 100$$

$$= 1.1 \times 10^{-3}$$

From eqn (i)

$$P = Y \cdot \frac{\Delta l}{l}$$

$$= 2 \times 10^{11} \times 1.1 \times 10^{-3}$$

$$P = 2.2 \times 10^8 \text{ Pa}$$

Hence, 43 → (2)

44. A block of mass m is placed on a surface with a vertical cross section given by $y = \frac{x^3}{6}$. If the coefficient of friction is 0.5, the maximum height above the ground at which the block can be placed without slipping is:

Sol. Given equation

$$Y = \frac{x^3}{6}$$

$$\mu = \tan \theta = \frac{dy}{dx} = \frac{3x^2}{6} = \frac{x^2}{2} = 0.5$$

$$x^2 = 1 \quad x = \pm 1$$

$$\text{Taking, } x > 0 \quad x = 1$$

$$H = (y)_{\max} = \frac{(1)^3}{6} = \frac{1}{6} \text{ m}$$

Hence, 44 → 2

45. Three rods of Copper, Brass and Steel are welded together to form a Y – shaped structure. Area of cross – section of each rod = 4 cm². End of copper rod is maintained at 100°C where as ends of brass and steel are kept at 0°C. Lengths of the copper, brass and steel rods are 46, 13 and 12 cms respectively. The rods are thermally insulated from surroundings except at ends. Thermal conductivities of copper, brass and steel are 0.92, 0.26 and 0.12 CGS units respectively. Rate of heat flow through copper rod is :

Sol. Area of cross section, $A = 4 \text{ cm}^2$

From the diagram

[diagram]

$$\left(\frac{\Delta\theta}{\Delta t}\right) = \left(\frac{\Delta\theta}{\Delta t}\right)_{Bran} + \left(\frac{\Delta\theta}{\Delta t}\right)_{Steel}$$

$$\frac{K \cdot A(100 - T)}{L_a} = \frac{K_B A(T - 0)}{L_B} + \frac{K_s A(T - 0)}{L_s}$$

$$\text{Solving} = \frac{0.92(100-T)}{46} = \frac{0.26T}{13} + \frac{0.12T}{12}$$

$$\Rightarrow 200 - 2T = 2T + T$$

$$T = 40^\circ\text{C}$$

$$\left(\frac{\Delta\theta}{\Delta t}\right)_w = \frac{0.92 \times 4 \times (100 - 40)}{46}$$

$$\left(\frac{\Delta\theta}{\Delta t}\right)_w = 4.8 \text{ cal/sec}$$

(45)→4

46. A mass 'm' is supported by a mass less string wound around a uniform hollow cylinder of mass m and radius R. If the string does not slip on the cylinder, with what acceleration will the mass fall on release?

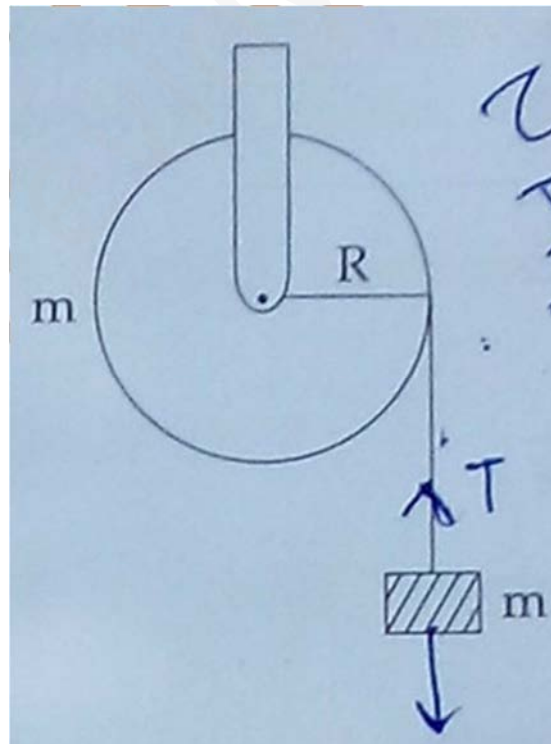

Sol. Linea force equation

$$Mg - T = ma \quad \dots(i)$$

Torque equation about centre

$$T.R = I \alpha \quad \dots(ii)$$

(I) Hollow cylinder = mR^2

Solving (i) and (ii) , we get

$$Mg - \frac{I\alpha}{R} = ma$$

$$\Rightarrow mg - \frac{mR^2}{2} \alpha = ma$$

$$\Rightarrow g = 2a$$

$$\Rightarrow a = \frac{g}{2}$$

Hence, 46 → 2

47. Match list – I (Electromagnetic wave type with List – II (Its association /application and select the correct option from the choice given below the lists :

	List – I		List – II
(a)	Infrared wave	(i)	To treat muscular strain
(b)	Radio waves	(ii)	For broadcasting
(c)	X – rays	(iii)	To detect fracture of bones
(d)	Ultraviolet	(iv)	Absorbed by the ozone layer of the atmosphere

Sol. Application of electromagnetic radiation

. Infrared radiation waves are used to target muscular strain.

. Radio wave are used for broad casting

. x – rays are used to detect fracture in the boner.

. U – V rays are used to absorbed by the ozone- layer of the atmosphere

Hence 47 → 3

48. The radiation corresponding to 3 → 2 Transition of hydrogen atom falls on a Metal surface to produce photoelectrons. These electrons are made to enter a magnetic field of 3×10^{-4} T. If the radius

of the largest circular path followed by these electrons is 10.0 mm, the work function of the metal is close to:

Sol. Radiation corresponding to $3 \rightarrow 2$

$$E = 13.6z^2 \left[\frac{1}{x_1^2} - \frac{1}{x_2^2} \right]$$

Since, $x_1 = 2, x_2 = 3$

$$E = 13.6z^2 \left[\frac{1}{2^2} - \frac{1}{3^2} \right] = 1.9 \text{ eV}$$

From photo electric effect eqn.

$$\phi = E - \frac{1}{2}mv^2$$

$$\phi = E - \frac{1}{2}m \left[\frac{q^2v^2B^2}{m^2} \right] - \left[v = \frac{qvB}{m} \right]$$

On substituting we get

$$\phi = 1.0 - 0.8 = 1.1 \text{ eV}$$

Hence, $48 \rightarrow 3$

49. During the propagation of electromagnetic waves in a medium :

Sol. We know

$$E_0 = cB_0 \quad \text{and } c = \frac{1}{\sqrt{\mu_0 \epsilon_0}}$$

$$\text{Electric energy density } \mu_E = \frac{1}{2} E_0 E_0$$

$$\text{Magnetic energy density } \mu_B = \frac{B_0^2}{2\mu_0}$$

Thus $\mu_E = \mu_B$

Hence, $49 \rightarrow 4$

50. A green light is incident from the water to the air – water interface at the critical angle(θ). Select the correct statement.

Sol. According to the critical angle concept

$$\sin \theta = \frac{1}{\mu} \quad \text{for } l < q$$

Of ' μ ' increase, wavelength (increase, wavelength (λ) would decrease

$$\mu \propto \frac{1}{\lambda}$$

And $\lambda \propto \frac{1}{f}$

Hence, frequency will increase,

The light with greater frequency will be totally intensity reflected

51. Four particles, each of mass M and equidistant from other, move along a circle of radius R under the action of their mutual gravitational attraction. The speed of each particle is :

1) $\frac{1}{2} \sqrt{\frac{GM}{R} (1 + 2\sqrt{2})}$

2) $\sqrt{\frac{GM}{R}}$

3) $\sqrt{2\sqrt{2} \frac{GM}{R}}$

4) $\sqrt{\frac{GM}{R} (1 + 2\sqrt{2})}$

Sol. The speed of each particle is gravitational force = centrepetal force

$$2F \cos 45 + F' = \frac{mv^2}{R}$$

$$\frac{2GMM}{(R)^2} \cos 45 + \frac{GMM}{(2R)^2} = \frac{MV^2}{R} \text{ solving, we get}$$

$$V = \frac{1}{2} \sqrt{\frac{GM}{R} (1 + \sqrt{2})}$$

52. A particle move with simple harmonic motion in a straight line. In first τ s, after starting from rest it travels a distance a, and in next τ s it travels 2a, in same direction, then :

1) Time period of oscillations is 6τ

2) Amplitude of motion is $3a$

3) Time period of oscillations is 8τ

4) Amplitude of motion is $4a$

Sol. in first ' τ ' sec, distance moved is 'a' and in next ' τ ' sec, distance moved is $2a$ '

$\frac{\tau}{2}$ — From the equation of SHM

$$x = A \cos \omega t$$

For case 1,

$A - x = A \cos \omega \tau$ (writing the equation of SHM from the mean position, where displacement becomes, $A-x$)

For case 2,

$$[A - (2a + a)] = A \cos \omega(\tau + \tau)$$

$\cos \omega \tau = \frac{A-a}{-A}$ and $(2 \cos^2 \omega \tau) - 1 = \frac{A-3a}{A}$ solving, these two equations, we get $a = A/2$ on substituting in equal (1)

$$A - \frac{A}{2} = A \cos \omega \tau = \omega \tau = \frac{\pi}{3} \quad T = 6\tau$$

53. A conductor lies along the z-axis at $-1.5 \leq z < 1.5$ m and carries a fixed current of 10.0 A in $-\hat{a}_z$ direction (see figure). For a field $\vec{B} = 3.0 \times 10^{-4} e^{-0.2x} \hat{a}_y$ T, find the power required to move the conductor at constant speed to $x = 2.0$ m, $y = 0$ m in 5×10^{-3} s. Assume parallel motion along the

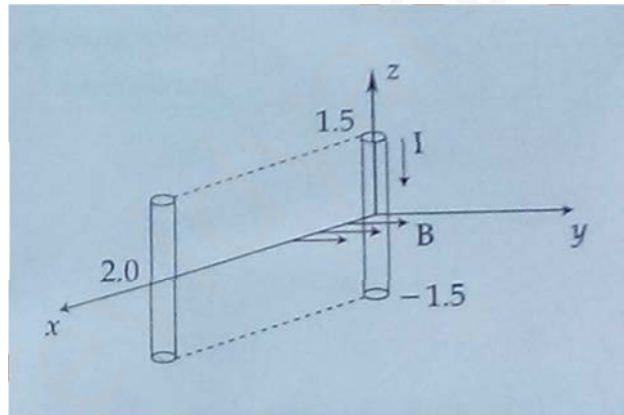

- 1) 29.7W
- 2) 1.57W
- 3) 2.97W
- 4) 14.85W

Sol. We know

$$\text{Power, } P = \int d\vec{f} \cdot \vec{v}$$

$$\text{Since, } d\vec{F} = I(d\vec{l} \times \vec{B})$$

$$P = Ilb \times 3 \times 10^{-4} \int_0^2 e^{-0.2x} dx$$

$$= \left[\frac{Iv \times 3 \times 10^{-4}}{0.2} e^{-0.4} - 1 \right] = 2.97w$$

Hence, 53 → 3

54. The forward biased diode connection is :

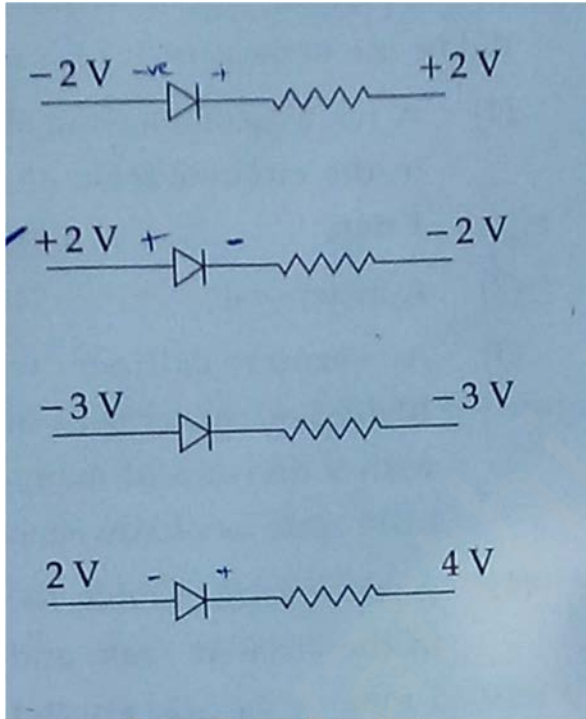

Sol. Toward biased connection, when positive terminal of the battery connected to the P-terminal source.

Hence, option 54 → (2)

55. Hydrogen (1H1), Deuterium (1H2), singly ionized Helium (2He4)+ and doubly ionized lithium (3Li6)+ all have one electron around the nucleus. Consider an electron transition from $n = 2$ to $n = 1$. If the wave lengths of emitted radiation are $\lambda_1, \lambda_2, \lambda_3,$ and λ_4 respectively then approximately which one of the following is correct ?

1) $\lambda_1 = 2\lambda_2 = 3\lambda_3 = 4\lambda_4$

2) $4\lambda_1 = 2\lambda_2 = 2\lambda_3 = \lambda_4$

3) $\lambda_1 = 2\lambda_2 = 2\lambda_3 = \lambda_4$

4) $\lambda_1 = \lambda_2 = 4\lambda_3 = 9\lambda_4$

Sol. According to Rydberg eqn- $\frac{1}{\lambda} = R_H Z^2 \left[\frac{1}{n_1^2} - \frac{1}{n_2^2} \right] = \frac{1}{\lambda} - Z^2 \times \left[\frac{1}{1^2} - \frac{1}{(2)^2} \right] = \frac{4}{3} Z^2$ and $\lambda = \frac{4}{3} Z^2$

Thus ratio, for $z = 1, z = 2, z = 3$, we get $\lambda_1 = \lambda_2 = 4 \times 3 = 9M$

Hence 55 \rightarrow (4s)

56) On heating water, bubbles being formed at the bottom of the vessel detach and rise. Take the bubbles to be spheres of radius R and making a circular contact of radius r with the bottom of the vessel. If $r \ll R$, and the surface tension of water is T value of r just before bubbles detach is :

Sol) Here the option given does not match the calculated answer.

Force inside bubble due to = force due to weight of water on bubble excess pressure

$$(2\pi r T) \sin \theta = \frac{4}{3} \pi R^3 P \omega g$$

$$T \times \frac{r}{R} \times 2\pi r = \frac{4}{3} \pi R^3 P \omega g$$

$$r^2 = \frac{2 R^4 P \omega g}{3 T}$$

$$r = R \sqrt{\frac{2 P \omega g}{3 T}}$$

57. A pipe of length 85 cm is closed from one end. Find the number of possible natural oscillations of air column in the pipe whose frequencies lie below 1250 Hz'. The velocity of sound in air is 340 m/s.

Sol:- Since, length of pipe,

$L = 85$ cm that is for

$$\lambda/4, \frac{3\lambda}{4}, \frac{5\lambda}{4}$$

$$f_1 = \frac{340}{\lambda} = 100 H_z, \text{ Similarly, } f_2 = 300 H_z$$

$$f_3 = 500 H_z, \quad f_4 = 700 H_z,$$

$$f_5 = 900 H_z, f_6 = 1100 H_z,$$

Hence, $n = 6$ $57 \rightarrow 4$

58 Assume that an electric field $E = 30x^2 \hat{i}$ exists in space. Then the potential difference $V_A - V_O$, where

V_O is the potential at the origin and V_A the potential at $x = 2$ m is :

Trans Web Educational Services Pvt. Ltd
B – 147, 1st Floor, Sec-6, NOIDA, UP-201301
Website: www.askiitians.com Email: info@askiitians.com
Tel: 1800-2000-838

Sol. $\vec{E} = 30x^2 \frac{A}{L}$

$$V_a - V_o = -\int E dx$$

$$= -\int_0^2 30x^2 dx$$

$$= -\left(\frac{30x^3}{3}\right)_0^2 = -80J$$

Hence, 58 →4

59. A student measured the length of a rod and wrote it as 3.50 cm. Which instrument did he use to measure it?

Sol. For a length to be measured

$$L = 3.50 \text{ cm.}$$

Here least count is , 01

Main scale division = 10 division in 1 cm

$$1 \text{ mm} = \frac{1}{10} \text{ cm} = 1 \text{ M}\leq\text{D}$$

Hence, 59-3

60. One mole of diatomic deal gas undergoes a cyclic process ABC as shown in figure. The process BC is adiabatic. The temperatures at A, B and C are 400 K, 800 K and 600 K respectively. Choose the correct statement:

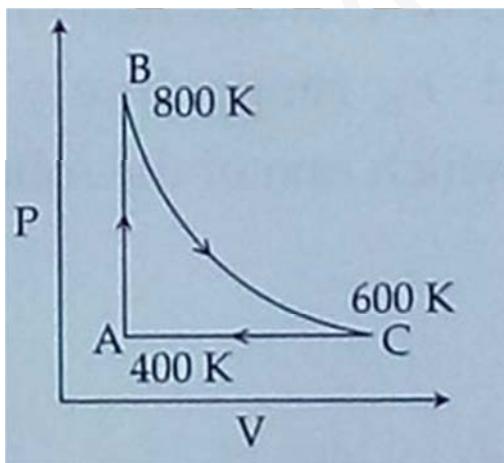

Sol. Changing in internal energy (ΔU) for cycle process $\Delta U=0$

ΔU_{4B} is positive as temperature is increases

Hence, $\Delta U_{BC} = n C_v \Delta T$

$$(\Delta U)_{BC} = -500 R$$

Hence, (60) \rightarrow (1)