

# AIPMT – 2009 PREVIOUS YEAR PAPER

**Q.1** If the dimensions of a physical quantity are given by  $[M^aL^bT^c]$ , then the physical quantity will be :

- (1) Force if  $a = 0, b = -1, c = -2$
- (2) Pressure if  $a = 1, b = -1, c = -2$
- (2) Velocity if  $a = 1, b = 0, c = -1$
- (3) Acceleration if  $a = 1, b = 1, c = -2$

**Q.2** A particle starts its motion from rest under the action of a constant force. If the distance covered in first 10 seconds is  $S_1$  and that covered in the first 20 seconds is  $S_2$  then :

- (1)  $S_2 = S_1$       (2)  $S_2 = 2S_1$
- (3)  $S_2 = 3S_1$       (4)  $S_2 = 4S_1$

**Q.3** A bus is moving with a speed of  $10\text{ms}^{-1}$  on a straight road. A scooterist wishes to overtake the bus in 100s. If the bus is at a distance of 1 km from the scooterist, with what speed should the scooterist chase the bus ?

- (1)  $10\text{ ms}^{-1}$  (2)  $20\text{ ms}^{-1}$
- (3)  $40\text{ ms}^{-1}$       (4)  $25\text{ ms}^{-1}$

**Q.4** The mass of lift is 2000 kg. When the tension in the supporting cable is 28000 N, then its acceleration is :

- (1)  $14\text{ ms}^{-2}$  upwards
- (2)  $30\text{ ms}^{-2}$  downwards
- (3)  $4\text{ ms}^{-2}$  upwards
- (4)  $4\text{ ms}^{-2}$  downwards

**Q.5** An explosion blows a rock into three parts. Two parts go off at right angles to each other. These two are, 1 kg first part moving with a velocity of  $12\text{ ms}^{-1}$  and 2 kg second part moving with a velocity of  $8\text{ ms}^{-1}$ . If the third part flies off with a velocity of  $4\text{ ms}^{-1}$ , its mass would be :

- (1) 3 kg      (2) 5 kg
- (3) 7 kg      (4) 17 kg

**Q.6** A block of mass  $M$  is attached to the lower end of a vertical spring. The spring is hung from a ceiling and has force constant value  $k$ . The mass is released from rest with the spring initially unstretched. The maximum extension produced in the length of the spring will be :

- (1)  $Mg/2k$       (2)  $Mg/k$   
(3)  $2 Mg/k$       (4)  $4 Mg/k$

**Q.7** Two bodies of mass 1 kg and 3 kg have position vectors  $k\hat{j} + 2\hat{i} + \hat{k}$  and  $k\hat{j} + 2\hat{i} - 3\hat{k}$ , respectively. The centre of mass of this system has a position vector :

- (1)  $k\hat{j} + \hat{i} + \hat{k}$       (2)  $k\hat{j} + 2\hat{i} - 2\hat{k}$   
(3)  $k\hat{j} + \hat{i} + 2\hat{k}$       (4)  $k\hat{j} + 2\hat{i} - \hat{k}$

**Q.8** Four identical thin rods each of mass  $M$  and length  $l$ , form a square frame. Moment of inertia of this frame about an axis through the centre of the square and perpendicular to its plane is :

- (1)  $\frac{1}{3} Ml^2$       (2)  $\frac{4}{3} Ml^2$   
(3)  $\frac{2}{3} Ml^2$       (4)  $\frac{13}{3} Ml^2$

**Q.9** A thin circular ring of mass  $M$  and radius  $R$  is rotating in a horizontal plane about an axis vertical to its plane with a constant angular velocity  $\omega$ . If two objects each mass  $m$  be attached gently to the opposite ends of a diameter of the ring, the ring will then rotate with an angular velocity :

- (1)  $\frac{\omega M}{M + m}$       (2)  $\frac{\omega(M - 2m)}{M + 2m}$   
(3)  $\frac{\omega M}{M + 2m}$       (4)  $\frac{\omega(M + 2m)}{M}$

**Q.10** A body, under the action of a force  $k\hat{j} + 8\hat{i} = F = 6 - \hat{r}$ , acquires an acceleration of  $1 \text{ m/s}^2$ . The mass of this body must be :

- (1)  $10 \text{ kg}$       (2)  $2 \text{ kg}$   
(3)  $10 \text{ kg}$       (4)  $20 \text{ kg}$

**Q.11** If  $F$  is the force acting on a particle having position vector  $r$  and  $\tau$  be the torque of this force about the origin, then :

- (1)  $r \cdot \tau = 0$  and  $F \cdot \tau \neq 0$

- (2)  $\mathbf{r} \cdot \boldsymbol{\tau} \neq 0$  and  $\mathbf{F} \cdot \boldsymbol{\tau} = 0$
- (3)  $\mathbf{r} \cdot \boldsymbol{\tau} > 0$  and  $\mathbf{F} \cdot \boldsymbol{\tau} < 0$
- (4)  $\mathbf{r} \cdot \boldsymbol{\tau} = 0$  and  $\mathbf{F} \cdot \boldsymbol{\tau} = 0$

**Q.12** The figure shows elliptical orbit of a planet  $m$  about the sun  $S$ . The shaded area  $SCD$  is twice the shaded area  $SAB$ .  $t_1$  is the time for the planet to move from  $C$  to  $D$  and  $t_2$  is the time to move from  $A$  to  $B$  then

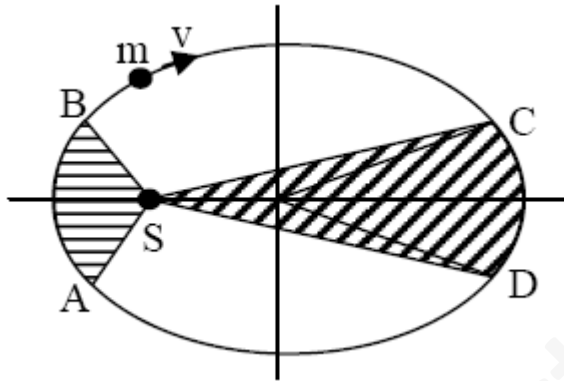

- (1)  $t_1 = t_2$       (2)  $t_1 > t_2$
- (3)  $t_1 = 4t_2$       (4)  $t_1 = 2t_2$

**Q.13** An engine pumps water continuously through a hose. Water leaves the hose with a velocity  $v$  and  $m$  is the mass per unit length of the water jet. What is the rate which kinetic energy is imparted to water ?

- (1)  $\frac{1}{2} m^2 v^2$       (2)  $\frac{1}{2} m v^3$
- (3)  $m v^3$       (4)  $\frac{1}{2} m v^2$

**Q.14** A body of mass 1 kg of thrown upwards with a velocity 20 m/s. It momentarily comes to rest after attaining a height of 18m. How much energy is lost due to air friction ?  
( $g = 10 \text{ m/s}^2$ )

- (1) 10 J    (2) 20 J    (3) 30 J    (4) 40 J

**Q.15** The two ends of a rod of length  $L$  and a uniform cross-sectional area  $A$  are kept at two  $dQ/dT$  temperatures  $T_1$  and  $T_2$  ( $T_1 > T_2$ ). The rate of heat transfer, through the rod in a steady state is given by :

$$(1) \frac{dQ}{dt} = \frac{kA(T_1 - T_2)}{L}$$

$$(2) \frac{dQ}{dt} = \frac{kL(T_1 - T_2)}{A}$$

$$(3) \frac{dQ}{dt} = \frac{k(T_1 - T_2)}{LA}$$

$$(4) \frac{dQ}{dt} = kLA(T_1 - T_2)$$

**Q.16** In thermodynamic processes which of the following statements is not true ?

- (1) In an adiabatic process  $PV_\gamma = \text{constant}$
- (2) In an adiabatic process the system is insulated from the surroundings
- (3) In an isochoric process pressure remains constant
- (4) In an isothermal process the temperature remains constant

**Q.17** A black body at  $227^\circ\text{C}$  radiates heat at the rate of  $7 \text{ cal/cm}^2\text{s}$ . At a temperature of  $727^\circ\text{C}$ , the rate of heat radiated in the same units will be :

- (1) 80    (2) 60    (3) 50    (4) 112

**Q.18** The internal energy change in a system that has absorbed 2 k cal of heat and done 500 J of work is :

- (1) 7900 J    (2) 8900 J  
(3) 6400 J    (4) 5400 J

**Q.19** The driver of a car traveling with speed 30 m/sec towards a hill sounds a horn of frequency 600 Hz. If the velocity of sound in air is 330m/s, the frequency of reflected sound as heard by driver is :

- (1) 500 Hz    (2) 550 Hz

- (3) 555.5 Hz      (4) 720 Hz

**Q.20** A simple pendulum performs simple harmonic motion about  $x = 0$  with an amplitude  $a$  and time period  $T$ . The speed of the pendulum at  $x = a/2$  will be :

- (1)  $\frac{\pi a \sqrt{3}}{T}$                       (2)  $\frac{\pi a \sqrt{3}}{2T}$
- (3)  $\frac{\pi a}{T}$                               (4)  $\frac{3\pi^2 a}{T}$

**Q.21** Which one of the following equations of motion represents simple harmonic motion ?

- (1) Acceleration =  $kx$
- (2) Acceleration =  $-k_0x + k_1x^2$
- (3) Acceleration =  $-k(x + a)$
- (4) Acceleration =  $k(x + a)$   
Where  $k, k_0, k_1$  and  $a$  are all positive

**Q.22** The electric field part of an electromagnetic wave in a medium is represented by :  
 $E_x = 0$

$$E_y = 2.5 \frac{N}{C} \cos \left[ \left( 2\pi \times 10^6 \frac{\text{rad}}{\text{m}} \right) t - \left( \pi \times 10^{-2} \frac{\text{rad}}{\text{s}} \right) x \right]$$

$E_z = 0$ . The wave is :

- (1) Moving along  $-x$  direction with frequency  $10^6$  Hz and wavelength 200m
- (2) Moving along  $y$  direction with frequency  $2\pi \times 10^6$  Hz and wavelength 200m
- (3) Moving along  $x$  direction with frequency  $10^6$  Hz and wavelength 100m
- (4) Moving along  $x$  direction with frequency  $10^6$  Hz and wavelength 200m

**Q.23** A wave in a string has an amplitude of 2 cm. The wave travels in the +ve direction of  $x$ -axis with a speed of 128 m/s and it is noted that 5 complete waves fit in 4 m length of the string. The equation describing the wave is

- (1)  $y = (0.02)\text{m} \sin (7.58x - 1005 t)$   
 (2)  $y = (0.02)\text{m} \sin (7.85x + 1005 t)$   
 (3)  $y = (0.02)\text{m} \sin (15.7x - 2010 t)$   
 (4)  $y = (0.02)\text{m} \sin (15.7x + 2010 t)$

**Q.24** Each of the two strings of length 51.6 cm and 49.1 cm are tensioned separately by 20 N force. Mass per unit length of both the strings is same and equal to 1 g/m. When both the strings vibrate simultaneously the number of beats is :

- (1) 3    (2) 5    (3) 7    (4) 8

**Q.25** Three capacitors each of capacitance  $C$  and of breakdown voltage  $V$  are joined in series. The Capacitance and

- (1)  $3C, 3V$                       (2)  $\frac{C}{3}, \frac{V}{3}$   
 (3)  $3C, \frac{V}{3}$                       (4)  $\frac{C}{3}, 3V$

**Q.26** A wire of resistance 12 ohms per metre is bent to form a complete circle of radius 10 cm. The Resistance between its two diametrically opposite points, A and B as shown in the figure, is :

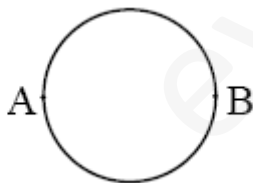

- (1)  $6 \Omega$     (2)  $0.6 \pi \Omega$     (3)  $3 \Omega$     (4)  $6 \pi \Omega$

**Q.27** A bar magnet having a magnetic moment of  $2 \times 10^4 \text{JT}^{-1}$  is free to rotate in a horizontal plane. A horizontal magnetic field  $B = 6 \times 10^{-4} \text{T}$  exists in the space. The work done in taking the magnet slowly from a direction parallel to the field to a direction  $60^\circ$  from the field is :

- (1) 2 J    (2) 0.6 J    (3) 12 J    (4) 6 J

**Q.28** The magnetic force acting on a charged particle of charge  $-2\mu\text{c}$  in a magnetic field of 2T acting in y direction, when the particle velocity is  $\hat{j} \wedge 3 \hat{i} (2 + \times 10^6 \text{ms}^{-1})$ , is :

- (1) 8N in z – direction
- (2) 8N in z – direction
- (3) 4N in z – direction
- (4) 8N in y – direction

**Q.29** A conducting circular loop is placed in a uniform magnetic field 0.04T with its plane perpendicular to the magnetic field. The radius of the loop starts shrinking at 2 mm/s. The induced emf in the loop when the radius is 2 cm is :

- (1)  $1.6 \pi \mu\text{v}$       (2)  $3.2 \pi \mu\text{v}$
- (3)  $4.8 \pi \mu\text{v}$       (4)  $0.8 \pi \mu\text{v}$

**Q.30** The electric potential at a point (x, y, z) is given by  $V = -xyz - xz^3 + 4$  The electric field  $E_r$  at that point is :

- (1)  $xz^3 \hat{k} - xy \hat{j} - zxy^2 \hat{i}$  ( $E = -3 + 2 + 2$ )
- (2)  $2xz^3 \hat{k} - x \hat{j} - zxy^2 \hat{i}$  ( $E = + + +$ )
- (3)  $yzx^3 \hat{k} - yx \hat{j} - xy^2 \hat{i}$  ( $E = + 2 + 2 - 2$ )
- (4)  $2xz^3 \hat{k} - xyz \hat{j} - z^2 \hat{i}$  ( $E = + + +$ )

**Q.31** See the electrical circuit shown in this figure. Which of the following equations is a correct equation for it ?

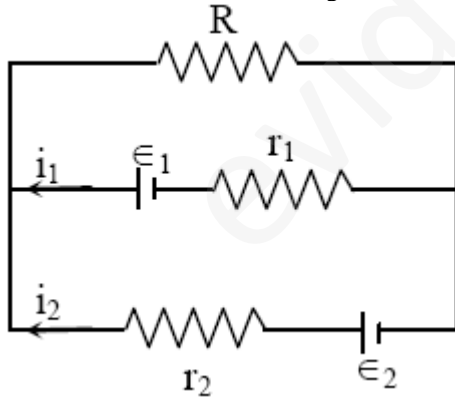

- (1)  $\epsilon_1 - (i_1 + i_2)R + i_1 r_1 = 0$
- (2)  $\epsilon_1 - (i_1 + i_2)R - i_1 r_1 = 0$
- (3)  $\epsilon_2 - i_1 r_2 - \epsilon_1 - i_1 r_1 = 0$
- (4)  $-\epsilon_2 - (i_1 + i_2)R + i_2 r_2 = 0$

**Q.32** A galvanometer having a coil resistance of  $60 \Omega$  shows full scale deflection when a current of  $1.0$  amp passes through it. It can be converted into an ammeter to read currents upto  $5.0$  amp by :

- (1) Putting in parallel a resistance of  $15 \Omega$
- (2) Putting in parallel a resistance of  $240 \Omega$
- (3) Putting in series a resistance of  $15 \Omega$
- (4) Putting in series a resistance of  $240 \Omega$

**Q.33** Under the influence of a uniform magnetic field, a charged particle moves with constant speed  $V$  in a circle of radius  $R$ . The time period of rotation of the particle :

- (1) Depends on both  $v$  and  $R$
- (2) Depends on  $v$  and not on  $R$
- (3) Depends on  $R$  and not on  $v$
- (4) Is independent of both  $v$  and  $R$

**Q.34** Power dissipated in an LCR series circuit connected to an a.c. source of emf  $\epsilon$  is :

- (1)  $\epsilon^2 R / \sqrt{R^2 + \left(L\omega - \frac{1}{C\omega}\right)^2}$
- (2)  $\epsilon^2 R / \left[ R^2 + \left(L\omega - \frac{1}{C\omega}\right)^2 \right]$
- (3)  $\epsilon^2 \sqrt{\left[ R^2 + \left(L\omega - \frac{1}{C\omega}\right)^2 \right]} / R$
- (4)  $\frac{\epsilon^2 \left[ R^2 + \left(L\omega - \frac{1}{C\omega}\right)^2 \right]}{R}$



**Q.35** Three concentric spherical shells have radii  $a$ ,  $b$ , and  $c$  ( $a < b < c$ ) and have surface charge densities  $\sigma$ ,  $-\sigma$  and  $\sigma$  respectively. If  $V_A$ ,  $V_B$  and  $V_C$  denote the potentials of the three shells, then, for  $c = a + b$ , we have :

- (1)  $V_C = V_B = V_A$  (2)  $V_C = V_A \neq V_B$   
 (3)  $V_C = V_B \neq V_A$  (4)  $V_C \neq V_B \neq V_A$

**Q.36** A student measures the terminal potential difference ( $V$ ) of a cell (of emf  $\epsilon$  and internal) resistance  $r$ ) as a function of the current ( $I$ ) flowing through it. The slope and intercept of the graph between  $V$  and  $I$ , then respectively equal to :

- (1)  $-\epsilon$  and  $r$  (2)  $\epsilon$  and  $-r$   
 (3)  $-r$  and  $\epsilon$  (4)  $r$  and  $-\epsilon$

**Q.37** A rectangular, a square, a circular and an elliptical loop, all in the  $(x - y)$  plane, are moving out of a uniform magnetic field with a constant velocity,  $\hat{i} \cdot \vec{V} = v \cdot \vec{r}$ . The magnetic field is directed along the negative  $z$ -axis direction. The induced emf, during the passage of these loops, come out of the field region, will not remain constant for :

- (1) any of the four loops  
 (2) The rectangular, circular and elliptical loops  
 (3) The circular and the elliptical loops  
 (4) Only the elliptical loop

**Q.38** If a diamagnetic substance is brought near the north or the south pole of a bar magnet, it is :

- (1) Attracted by both the poles  
 (2) Repelled by both the poles  
 (3) Repelled by the north pole and attracted by the south pole  
 (4) Attracted by the north pole and repelled by the south pole

**Q.39** The number of photoelectrons emitted for light of a frequency  $\nu$  (higher than the threshold frequency  $\nu_0$ ) is proportional to :

- (1) Frequency of light ( $\nu$ )  
 (2)  $\nu - \nu_0$   
 (3) Threshold frequency ( $\nu_0$ )  
 (4) Intensity of light

**Q.40** Monochromatic light of wavelength  $667 \text{ nm}$  is produced by a helium neon laser. The power emitted is  $9 \text{ mW}$ . The number of photons arriving per second on the average at a target irradiated by this beam is :

- (1)  $3 \times 10^{19}$  (2)  $9 \times 10^{17}$   
(3)  $3 \times 10^{16}$  (4)  $9 \times 10^{15}$

**Q.41** The figure shows a plot of photo current versus anode potential for a photo sensitive surface for three different radiations. Which one of the following is a correct statement ?

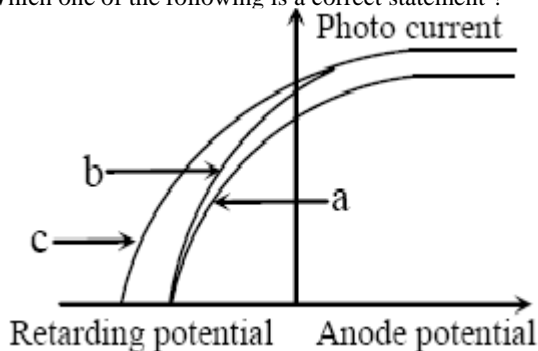

- (1) Curves (b) and (c) represent incident radiations same frequencies having same intensity.  
(2) Curves (a) and (b) represent incident radiations of different frequencies and different intensities  
(3) Curves (a) and (b) represent incident radiations of same frequencies but of different intensities  
(4) Curves (b) and (c) represent incident radiations of different frequencies and different intensities

**Q.42** The number of beta particles emitted by a radioactive substance is twice the number of alpha particles emitted by it. The resulting daughter is an :

- (1) Isotope of parent (2) Isobar of parent  
(3) Isomer of parent (4) Isotone of parent

**Q.43** The ionization energy of the electron in the hydrogen atom in its ground state is 13.6 eV. The atoms are excited to higher energy levels to emit radiations of 6 wavelengths. Maximum wavelength of emitted radiation corresponds to the transition between :

- (1)  $n = 4$  to  $n = 3$  states  
(2)  $n = 3$  to  $n = 2$  states  
(3)  $n = 3$  to  $n = 1$  states  
(4)  $n = 2$  to  $n = 1$  states

**Q.44** In a Rutherford scattering experiment when a projectile of charge  $Z_1$  and mass  $M_1$  approaches a target nucleus of charge  $Z_2$  and mass  $M_2$ , the distance of closest approach is  $r_0$ . The energy of the projectile is :

- (1) Directly proportional to mass  $M_1$   
(2) Directly proportional to  $M_1 \times M_2$



(3) Directly proportional to  $Z_1 Z_2$

(4) Inversely proportional to  $Z_1$

**Q.45** In the nuclear decay given below :

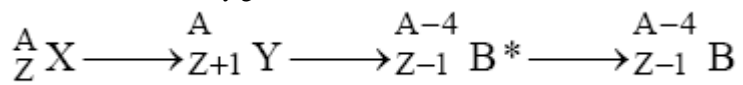

The particles emitted in the sequence are :

- (1)  $\alpha, \beta, \gamma$     (2)  $\beta, \alpha, \gamma$     (3)  $\gamma, \beta, \alpha$     (4)  $\beta, \gamma, \alpha$

**Q.46** The mean free path of electrons in a metal is  $4 \times 10^{-8}$  m. The electric field which can give on an average 2 eV energy to an electron in the metal will be in units of V/m :

- (1)  $5 \times 10^7$     (2)  $8 \times 10^7$   
(3)  $5 \times 10^{-11}$     (4)  $8 \times 10^{-11}$

**Q.47** Sodium has body centred packing. Distance between two nearest atoms is 3.7 Å. The lattice parameter is :

- (1) 8.6 Å    (2) 6.8 Å    (3) 4.3 Å    (4) 3.0 Å

**Q.48** A p-n photodiode is fabricated from a semiconductor with a band gap of 2.5 eV. It can detect a signal of wavelength :

- (1) 496 Å    (2) 6000 Å  
(3) 4000 nm    (4) 6000 nm

**Q.49** The symbolic representation of four logic gates are given below :

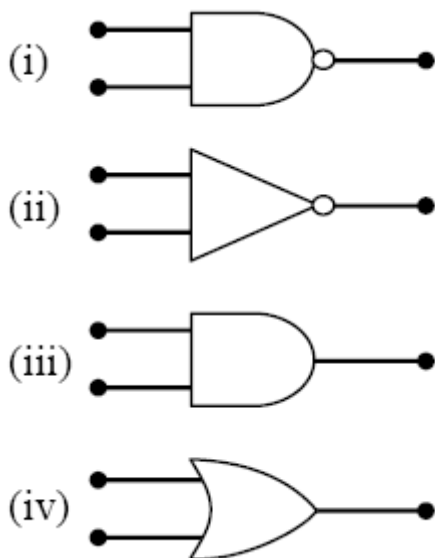

The logic symbols for OR, NOT and NAND gates are respectively :

- (1) (i), (iii), (iv)
- (2) (iii), (iv), (ii)
- (3) (iv), (i), (iii)
- (4) (iv), (ii), (i)

**Q.50** A transistor is operated in common-emitter configuration at  $V_c = 2V$  such that a change in the base current from  $100 \mu A$  to  $200 \mu A$  produces a change in the collector current from  $5 mA$  to  $10 mA$ . The current gain is :

- (1) 50    (2) 75    (3) 100    (4) 150

**Q.51**  $10 g$  of hydrogen and  $64 g$  of oxygen were filled in a steel vessel and exploded. Amount of water produced in this reaction will be –

- (1) 1 mol    (2) 2 mol
- (3) 3 mol    (4) 4 mol

**Q.52** Oxidation number of P in  $3-4 PO$ , of S in  $-24SO$  and that of Cr in  $2- Cr_2O_7$  are respectively :

- (1) +3, +6 and +6
- (2) +5, +6 and +6
- (3) +3, +6 and +5
- (4) +5, +3 and +6

**Q.53** Maximum number of electrons in a subshell or an atom is determined by the following :

- (1)  $2n^2$
- (2)  $4l + 2$
- (3)  $2l + 2$
- (4)  $4l - 2$

**Q.54** Which of the following is not permissible arrangement of electrons in an atom ?

- (1)  $n = 3, l = 2, m = -3, s = -\frac{1}{2}$
- (2)  $n = 4, l = 0, m = 0, s = +\frac{1}{2}$
- (3)  $n = 5, l = 3, m = 0, s = +\frac{1}{2}$
- (5)  $n = 3, l = 2, m = -3, s = -\frac{1}{2}$

**Q.55** From the following bond energies :

H – H bond energy :  $431.37 \text{ kJ mol}^{-1}$

C = C bond energy :  $606.10 \text{ kJ mol}^{-1}$

C – C bond energy :  $336.49 \text{ kJ mol}^{-1}$

C – H bond energy :  $410.50 \text{ kJ mol}^{-1}$

Enthalpy for the reaction,

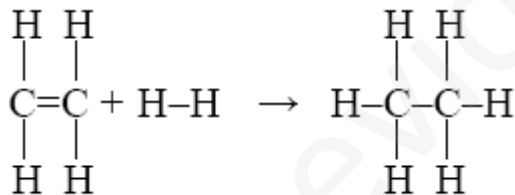

will be :

- (1)  $553.0 \text{ kJ mol}^{-1}$       (2)  $1523.6 \text{ kJ mol}^{-1}$
- (3)  $-243.6 \text{ kJ mol}^{-1}$       (4)  $-120.0 \text{ kJ mol}^{-1}$

**Q.56** The ionization constant of ammonium hydroxide is  $1.77 \times 10^{-5}$  at 298 K. Hydrolysis constant of ammonium chloride

- (1)  $5.65 \times 10^{-12}$       (2)  $5.65 \times 10^{-10}$
- (3)  $6.50 \times 10^{-12}$       (4)  $5.65 \times 10^{-13}$

**Q.57** Given :

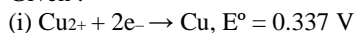



Electrode potential  $E^\circ$  for the reaction,

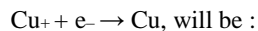

- (1) 0.38 V      (2) 0.52 V  
(3) 0.90 V      (4) 0.30 V

**Q.58** What is the  $[\text{OH}^-]$  in the final solution prepared by mixing 20.0 mL of 0.050 M HCl with 30.0 mL of 0.10 M  $\text{Ba}(\text{OH})_2$  ? –

- (1) 0.12 M      (2) 0.10 M  
(3) 0.40 M      (4) 0.0050 M

**Q.59** The energy absorbed by each molecule ( $A_2$ ) of a substance is  $4.4 \times 10^{-19} \text{ J}$  and bond energy per molecule is  $4.0 \times 10^{-19} \text{ J}$ . The kinetic energy of the molecule per atom will be :

- (1)  $4.0 \times 10^{-20} \text{ J}$       (2)  $2.0 \times 10^{-20} \text{ J}$   
(3)  $2.2 \times 10^{-19} \text{ J}$       (4)  $4 \times 10^{-19} \text{ J}$

**Q.60** For the reaction,  $\text{N}_2 + 3\text{H}_2 \rightarrow 2\text{NH}_3$ ,

If  $\frac{d[\text{NH}_3]}{dt} = 2 \times 10^{-4} \text{ mol L}^{-1} \text{ s}^{-1}$ , The value of  $\frac{-d[\text{H}_2]}{dt}$

would be -

- (1)  $1 \times 10^{-4} \text{ mol L}^{-1} \text{ s}^{-1}$   
(2)  $3 \times 10^{-4} \text{ mol L}^{-1} \text{ s}^{-1}$   
(3)  $4 \times 10^{-4} \text{ mol L}^{-1} \text{ s}^{-1}$   
(4)  $6 \times 10^{-4} \text{ mol L}^{-1} \text{ s}^{-1}$

**Q.61** For the reaction  $\text{A} + \text{B} \rightarrow \text{products}$ , it is observed that :

- (1) On doubling the initial concentration of A only, the rate of reaction is also doubled and  
(2) On doubling the initial concentration of both A and B, there is a change by a factor of 8 in the rate of the reaction.

The rate of this reaction is given by :

- (1)  $\text{rate} = k[\text{A}][\text{B}]$   
(2)  $\text{rate} = k[\text{A}]^2[\text{B}]$   
(3)  $\text{rate} = k[\text{A}][\text{B}]^2$   
(4)  $\text{rate} = k[\text{A}]^2[\text{B}]^2$

**Q.62** The equivalent conductance of 32 M solution of a weak monobasic acid is 8.0 mho cm<sup>2</sup> and at infinite dilution is 400 mho cm<sup>2</sup>, The dissociation constant of this acid is –

- (1)  $1.25 \times 10^{-4}$   
 (2)  $1.25 \times 10^{-5}$   
 (3)  $1.25 \times 10^{-6}$   
 (4)  $6.25 \times 10^{-4}$

**Q.63** A 0.0020 M aqueous solution of an ionic compound  $\text{Co}(\text{NH}_3)_5(\text{NO}_2)\text{Cl}$  freezes at  $-0.00732^\circ\text{C}$ . Number of moles of ions which 1 mole of ionic compound produces on being dissolved in water will be : ( $k_f = 1.86^\circ\text{C}/\text{m}$ ) –

- (1) 1                      (2) 2  
 (3) 3                      (4) 4

**Q.64** In the reaction

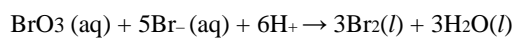

The rate of appearance of bromine ( $\text{Br}_2$ ) is related to rate of disappearance of bromide ions as following

(1)  $\frac{d(\text{Br}_2)}{dt} = \frac{3}{5} \frac{d(\text{Br}^-)}{dt}$

(2)  $\frac{d(\text{Br}_2)}{dt} = -\frac{3}{5} \frac{d(\text{Br}^-)}{dt}$

(3)  $\frac{d(\text{Br}_2)}{dt} = -\frac{5}{3} \frac{d(\text{Br}^-)}{dt}$

(4)  $\frac{d(\text{Br}_2)}{dt} = \frac{5}{3} \frac{d(\text{Br}^-)}{dt}$

**Q.65** Lithium metal crystallizes in a body centred cubic crystal. If the length of the side of the unit cell of lithium is 351 pm, the atomic radius of lithium will be :

- (1) 300.5 pm              (2) 240.8 pm  
 (3) 151.8 pm              (4) 75.5 pm

**Q.66** The dissociation constants for acetic acid and HCN at 25°C are  $1.5 \times 10^{-5}$  and  $4.5 \times 10^{-10}$ , respectively. The equilibrium constant for the equilibrium –

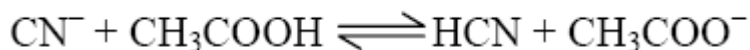

would be :

- (1)  $3.0 \times 10^4$       (2)  $3.0 \times 10^5$   
 (3)  $3.0 \times 10^{-5}$     (4)  $3.0 \times 10^{-4}$

**Q.67** The values of  $\Delta H$  and  $\Delta S$  for the reaction,  $\text{C}(\text{graphite}) + \text{CO}_2(\text{g}) \rightarrow 2\text{CO}(\text{g})$  are 170 kJ and 170 JK<sup>-1</sup> respectively. This reaction will be spontaneous at –

- (1) 510 K      (2) 710 K  
 (3) 910 K      (4) 1110 K

**Q.67** The values of  $\Delta H$  and  $\Delta S$  for the reaction,  $\text{C}(\text{graphite}) + \text{CO}_2(\text{g}) \rightarrow 2\text{CO}(\text{g})$  are 170 kJ and 170 JK<sup>-1</sup> respectively. This reaction will be spontaneous at –

- (1) 510 K      (2) 710 K  
 (3) 910 K      (4) 1110 K

**Q.69** In which of the following molecules / ions  $\text{BF}_3$ ,  $-\text{2NO}$ ,  $-\text{2NH}$  and  $\text{H}_2\text{O}$ , the central atom is  $\text{sp}^2$  hybridized ?

- (1)  $\text{BF}_3$  and  $-\text{2NO}$   
 (2)  $-\text{2NO}$  and  $\text{NH}_2$   
 (3)  $-\text{2NH}$  and  $\text{H}_2\text{O}$ ,  
 (4)  $-\text{2NO}$  and  $\text{H}_2\text{O}$

**Q.70** Among the following which is the strongest oxidizing agent ? –

- (1)  $\text{Cl}_2$       (2)  $\text{F}_2$   
 (3)  $\text{Br}_2$       (3)  $\text{I}_2$

**Q.71** According to MO theory which of the following lists ranks the nitrogen species in terms of increasing bond order :

- (1)  $\text{N}_2^- < \text{N}_2^{2-} < \text{N}_2$       (2)  $\text{N}_2^- < \text{N}_2 < \text{N}_2^{2-}$   
 (3)  $\text{N}_2^{2-} < \text{N}_2^- < \text{N}_2$       (4)  $\text{N}_2 < \text{N}_2^{2-} < \text{N}_2^-$

**Q.72** In the case of alkali metals, the covalent character decreases in the order :



- (1)  $MI > MBr > MCl > MF$
- (2)  $MCl > MI > MBr > MF$
- (3)  $MF > MCl > MBr > MI$
- (4)  $MF > MCl > MI > MBr$

**Q.73** Which of the following oxides is not expected to react with sodium hydroxide ?

- (1) BeO    (2) B<sub>2</sub>O<sub>3</sub>    (3) CaO    (4) SiO<sub>2</sub>

**Q.74** Al<sub>2</sub>O<sub>3</sub> is reduced by electrolysis at low potentials and high currents. If  $4.0 \times 10^4$  amperes of current is passed through molten Al<sub>2</sub>O<sub>3</sub> for 6 hours, what mass of aluminium is produced ? (Assume 100% current efficiency, at. mass of Al = 27 g mol<sup>-1</sup>) –

- (1)  $1.3 \times 10^4$  g            (2)  $9.0 \times 10^3$  g
- (3)  $8.1 \times 10^4$  g            (4)  $2.4 \times 10^5$  g

**Q.75** The stability of +1 oxidation state increases in the sequence :

- (1) Ga < In < Al < Tl            (2) Al < Ga < In < Tl
- (3) Tl < In < Ga < Al            (4) In < Tl < Ga < Al

**Q.76** Copper crystallizes in a face-centred cubic lattice with a unit cell length of 361 pm. What is the radius of copper atom in pm ?

- (1) 108    (2) 128    (3) 157    (4) 181

**Q.77** What is the dominant intermolecular force or bond that must be overcome in converting liquid CH<sub>3</sub>OH to a gas –

- (1) London dispersion force
- (2) Hydrogen bonding
- (3) Dipole-dipole interaction
- (4) Covalent bonds

**Q.78** Which of the following complex ions is expected to absorb visible light ? (At no. Zn = 30, Sc = 21, Ti = 22, Cr = 24)

- (1) [Zn(NH<sub>3</sub>)<sub>6</sub>]<sup>2+</sup>            (2) [Sc(H<sub>2</sub>O)<sub>3</sub>(NH<sub>3</sub>)<sub>3</sub>]<sup>3+</sup>
- (3) [Ti(en)<sub>2</sub>(NH<sub>3</sub>)<sub>2</sub>]<sup>4+</sup>            (4) [Cr(NH<sub>3</sub>)<sub>6</sub>]<sup>3+</sup>

**Q.79** Out of  $\text{TiF}_6^{2-}$  and  $\text{CoF}_6^{3-}$ ,  $\text{Cu}_2\text{Cl}_2$  and  $\text{NiCl}_4^{2-}$  (Z of Ti = 22, Co = 27, Cu = 29, Ni = 28) the colourless species are : -

- (1)  $\text{CoF}_6^{3-}$  and  $\text{NiCl}_4^{2-}$
- (2)  $\text{TiF}_6^{2-}$  and  $\text{CoF}_6^{3-}$
- (3)  $\text{Cu}_2\text{Cl}_2$  and  $\text{NiCl}_4^{2-}$
- (4)  $\text{TiF}_6^{2-}$  and  $\text{Cu}_2\text{Cl}_2$

**Q.80** Which of the following does not show optical isomerism -

- (1)  $[\text{Co}(\text{en})_3]^{3+}$
- (2)  $[\text{Co}(\text{en})_2\text{Cl}_2]^+$
- (3)  $[\text{Co}(\text{NH}_3)_3\text{Cl}_3]^o$
- (4)  $[\text{Co}(\text{en})\text{Cl}_2(\text{NH}_3)_2]^+$   
(en = Ethylenediamine)

**Q.81** Which one of the elements with the following outer orbital configurations may exhibit the largest number of oxidation states ?

- (1)  $3d^24s^2$
- (2)  $3d^34s^2$
- (3)  $3d^54s^1$
- (4)  $3d^54s^2$

**Q.82** Which of the following molecules acts as a Lewis acid ?

- (1)  $(\text{CH}_3)_3\text{N}$
- (2)  $(\text{CH}_3)_3\text{B}$
- (3)  $(\text{CH}_3)_2\text{O}$
- (4)  $(\text{CH}_3)_3\text{P}$

**Q.83** Amongst the element with following electronic configurations, which one of them may have the highest ionization energy ?

- (1)  $[\text{Ne}]3s^23p^1$
- (2)  $[\text{Ne}]3s^23p^3$
- (3)  $[\text{Ne}]3s^23p^2$
- (4)  $[\text{Ar}]3d^{10}4s^2 4p^3$

**Q.84** The straight chain polymer is formed by –

- (1) hydrolysis of  $(\text{CH}_3)_2\text{SiCl}_2$  followed by condensation polymerization
- (2) hydrolysis of  $(\text{CH}_3)_3\text{SiCl}$  followed by condensation polymerization
- (3) hydrolysis of  $\text{CH}_3\text{SiCl}_3$  followed by condensation polymerization
- (4) hydrolysis of  $(\text{CH}_3)_4\text{Si}$  by addition Polymerization

**Q.85** The IUPAC name of the compound having the n formula  $\text{CH}\equiv\text{C}-\text{CH}=\text{CH}_2$  is -

- (1) 1-butene-3-yne
- (2) 3-buten-1-yne
- (3) 1-butyne-3-ene
- (4) but-1-yn-3-ene

**Q.86** Which of the following compounds will exhibit *cis-trans* (geometrical) isomerism ?

- (1) 1-Butanol
- (2) 2-Butene
- (3) 2-Butanol
- (4) 2-Butyne

**Q.87**  $\text{H}_2\text{COH}.\text{CH}_2\text{OH}$  on heating with periodic acid gives :

- (1)  $2 \begin{array}{l} \text{H} \\ \diagdown \\ \text{C}=\text{O} \\ \diagup \\ \text{H} \end{array}$
- (2)  $2\text{CO}_2$
- (3)  $2\text{HCOOH}$
- (4)  $\begin{array}{c} \text{CHO} \\ | \\ \text{CHO} \end{array}$

**Q.88** Consider the following reaction

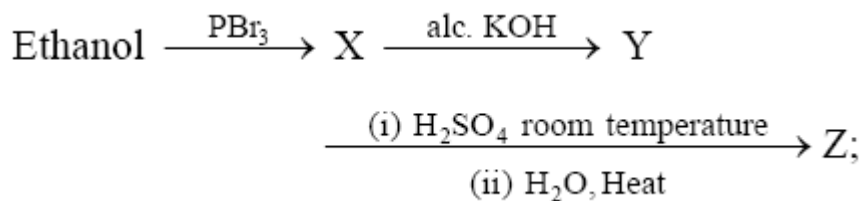

- (2)  $\text{CH}_2 = \text{CH}_2$
- (3)  $\text{CH}_3\text{CH}_2-\text{O}-\text{CH}_2\text{CH}_3$

(4)  $\text{CH}_3\text{CH}_2\text{-O-SO}_3\text{H}$

**Q.89** Benzene reacts with  $\text{CH}_3\text{Cl}$  in the presence of anhydrous  $\text{AlCl}_3$  to form –

- (1) Xylene
- (2) Toluene
- (3) Chlorobenzene
- (4) Benzylchloride

**Q.90** Nitrobenzene can be prepared from benzene by using a mixture of conc.  $\text{HNO}_3$  and conc.  $\text{H}_2\text{SO}_4$ . In the mixture, nitric acid acts as a/an –

- (1) catalyst
- (2) reducing agent
- (3) acid
- (4) base

**Q.91** Which of the following reactions is an example of nucleophilic substitution reaction ?

- (1)  $\text{RX} + \text{Mg} \rightarrow \text{RMgX}$
- (2)  $\text{RX} + \text{KOH} \rightarrow \text{ROH} + \text{KX}$
- (3)  $2\text{RX} + 2\text{Na} \rightarrow \text{R-R} + 2\text{NaX}$
- (4)  $\text{RX} + \text{H}_2 \rightarrow \text{RH} + \text{HX}$

**Q.92** Which one of following is employed as a tranquilizer ?

- (1) Chlorpheninamine
- (2) Equanil
- (3) Naproxen
- (4) Tetracycline

**Q.93** Structures of some common polymers are given which one is not correctly presented ?

(1) Nylon 66

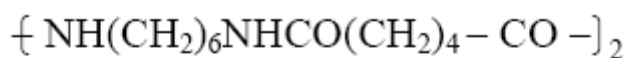

(2) Teflon

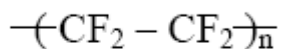

(3) Neoprene

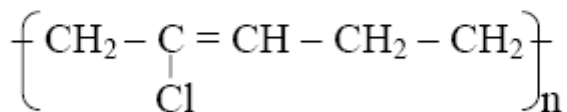

(4) Terylene

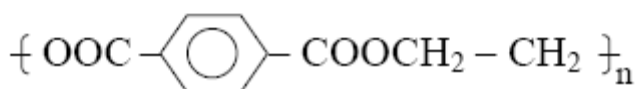

**Q.94** Predict the product :

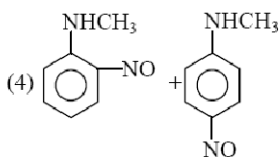
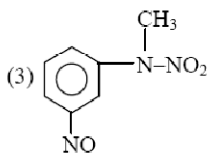
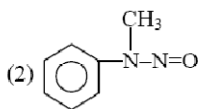
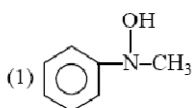
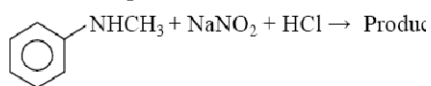

**Q.95** Propionic acid with  $\text{Br}_2/\text{P}$  yields a dibromo product, Its structure would be –

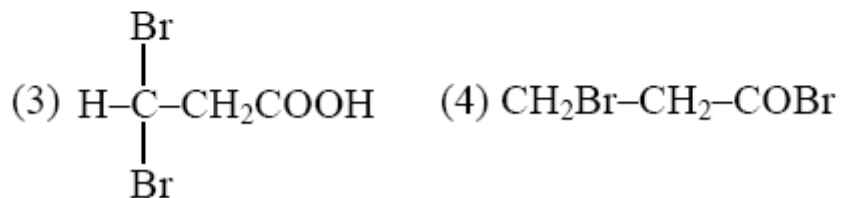
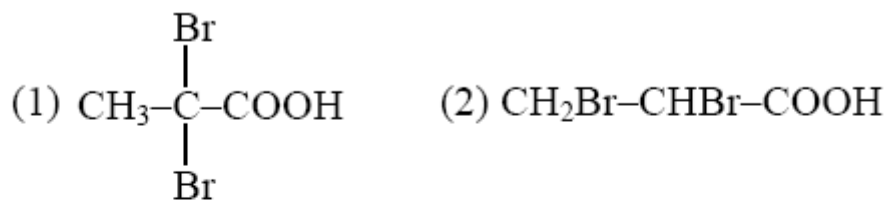

Q.96 Trichloroacetaldehyde,  $\text{CCl}_3\text{CHO}$  reacts with chlorobenzene in presence of sulphuric acid and produces –

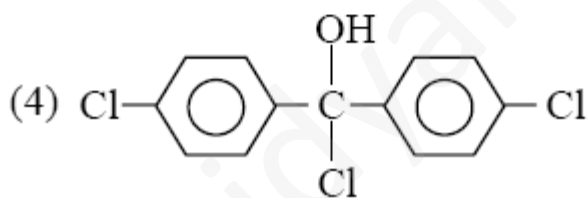
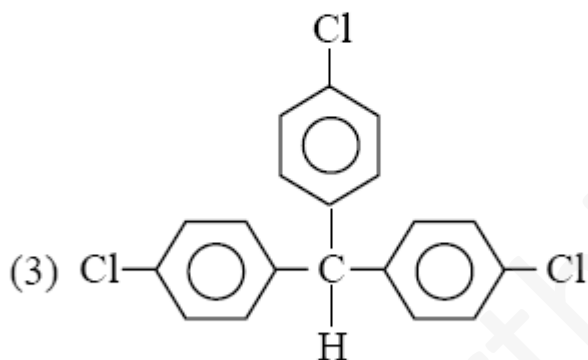
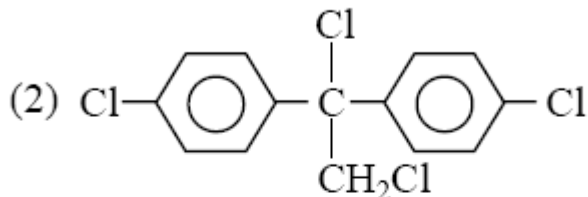
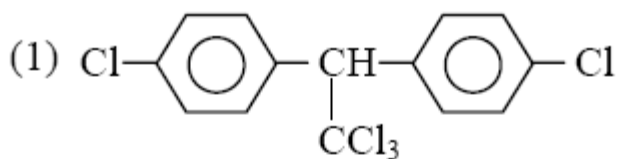

Q.97 Consider the following reaction :

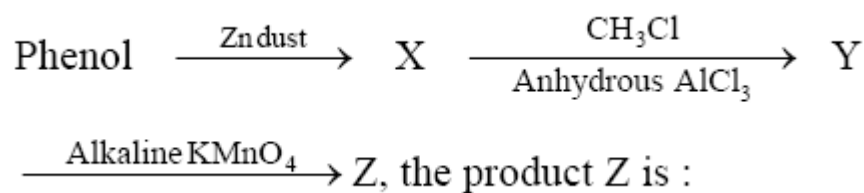

- (1) Benzene                      (2) Toluene  
 (3) Benzaldehyde              (4) Benzoic acid

Q.98 The state of hybridization of C<sub>2</sub>, C<sub>3</sub>, C<sub>5</sub> and C<sub>6</sub> of the hydrocarbon –

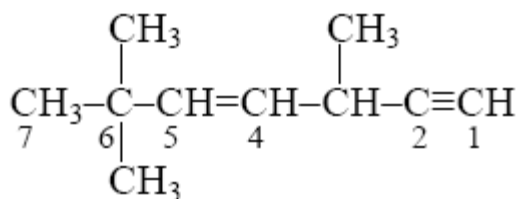

is in the following sequence :

- (1) sp, sp<sup>2</sup>, sp<sup>3</sup> and sp<sup>2</sup>      (2) sp, sp<sup>3</sup>, sp<sup>2</sup> and sp<sup>3</sup>  
 (3) sp<sup>3</sup>, sp<sup>2</sup>, sp<sup>2</sup> and sp      (4) sp, sp<sup>2</sup>, sp<sup>2</sup> and sp<sup>3</sup>

**Q.99** The segment of DNA which acts as the instrument manual for the synthesis of the protein is :

- (1) Nucleoside      (2) Nucleotide  
 (3) Ribose      (4) Gene

**Q.100** Which of the following hormones contains iodine ?

- (1) Thyroxine      (2) Insuline  
 (3) Testosterone      (4) Adrenaline

**Q.101** Which one of the following has haplontic life cycle ?

- (1) Wheat      (2) Funaria  
 (3) *Polytrichum*      (4) Ustilago

**Q.102** T.O.Diener discovered a :

- (1) Bacteriophage  
 (2) Free infection DNA  
 (3) Free infectious RNA  
 (4) Infectious protein

**Q.103** Mannitol is the stored food in –

- (1) Gracillaria      (2) Chara  
 (3) Porphyra      (4) Fucus

**Q.104** Which one of the following is a vascular cryptogram ?

- (1) Cedrus (2) Equisetum



(3) Ginkgo (4) Marchantia

**Q.105** Phylogenetic system of classification is based on:

- (1) Floral characters
- (2) Evolutionary relationships
- (3) Morphological features
- (4) Chemical constituents

**Q.106** Which one of the following groups of animals is bilaterally symmetrical and triploblastic ?

- (1) Sponges
- (2) Coelentrates (Cnidarians)
- (3) Aschelminthes (round worms)
- (4) Ctenophores

**Q.107** Peripatus is a connecting link between :

- (1) Coelenterata and Porifera
- (2) Ctenophora and Platyhelminthes
- (3) Mollusca and Echinodermata
- (4) Annelida and Arthropoda

**Q.108** Which one of the following pairs of animals comprises 'Jawless fishes' ?

- (1) Guppies and hag fishes
- (2) Lampreys and eels
- (3) Mackerals and Rohu
- (4) Lampreys and hag fishes

**Q.109** If a live earthworm is pricked with a needle on its outer surface without damaging its gut, the fluid that comes out is :

- (1) Slimy mucus
- (2) excretory fluid
- (3) Coelomic fluid
- (4) haemolymph

**Q.110** Plasmodesmata are :

- (1) Connection between adjacent cells
- (2) Lignified cemented layers between cells
- (3) Locomotory structures
- (4) Membranes connecting the nucleus with Plasmalemma

**Q.111** Stroma in the chloroplast of higher plant contains :

- (1) Chlorophyll
- (2) Light-independent reaction enzymes
- (3) Light-dependent reaction enzymes
- (4) Ribosomes

**Q.112** Synapsis occurs between :

- (1) two homolog chromosomes
- (2) a male and a female gamete
- (3) mRNA and ribosomes
- (4) spindle fibres and centromere

**Q.113** Middle lamella is composed mainly of :

- |                       |                     |
|-----------------------|---------------------|
| (1) Phosphoglycerides | (2) Hemicellulose   |
| (3) Muramic acid      | (4) Calcium pectate |

**Q.114** Cytoskeleton is made up of :

- (1) Proteinaceous filaments
- (2) Calcium carbonate granules
- (3) Callose deposits
- (4) Cellulose microfibrils

**Q.115** The cell junctions called tight, adhering and gap junctions are found in :

- (1) Neural tissue                      (2) Muscular tissue  
(3) Connective tissue                (4) Epithelial tissue

**Q.116** The kind of tissue that forms the supportive structure in our pinna (external ears) is also found in –

- (1) tip of the nose                      (2) vertebrae  
(3) nails                                      (4) ear ossicles

**Q.117** The epithelial tissue present on the inner surface of bronchioles and fallopian tubes is :

- (1) Squamous                              (2) Cuboidal  
(3) Glandular                              (4) Ciliated

**Q.118** Given below is a schematic break-up of the phases / stages of cell cycle :

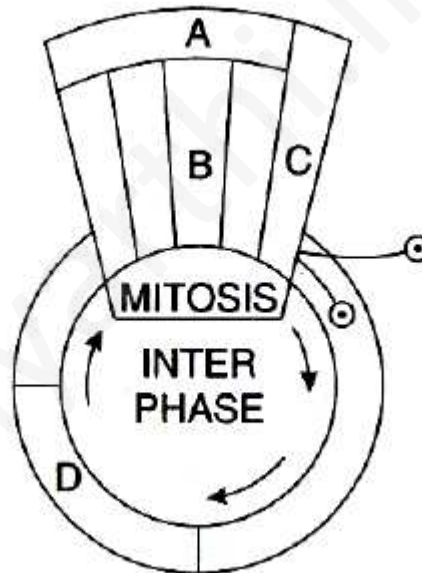

Which one of the following is the correct indication of the stage / phase in the cell cycle ?

- (1) A-Cytokinesis                      (2) B-Metaphase  
(3) C-Karyokinesis                      (4) D-Synthetic phase

**Q.119** What is not true for genetic code?

- (1) It is unambiguous  
(2) A codon in mRNA is read in a noncontiguous Fashion  
(3) It is nearly universal

(4) It is degenerate

**Q.120** Removal of introns and joining the exons in a defined order in a transcription unit is called :

- (1) Capping
- (2) Splicing
- (3) Tailing
- (4) Transformation

**Q.121** Semiconservative replication of DNA was first demonstrated in :

- (1) *Salmonella typhimurium*
- (2) *Drosophila melanogaster*
- (3) *Escherichia coli*
- (4) *Streptococcus pneumonia*

**Q.122** Whose experiments cracked the DNA and discovered unequivocally that a genetic code is a "triplet" ?

- (1) Beadle and Tatum
- (2) Nirenberg and Mathaei
- (3) Hershey and Chase
- (4) Morgan and Sturtevant

**Q.123** Point mutation involves :

- (1) Deletion
- (2) Insertion
- (3) Change in single base pair
- (4) Duplication

**Q.124** In the case of peppered moth (*Biston betularia*) the black-coloured form became dominant over the light-coloured form in England during industrial revolution. This is an example of –

- (1) Inheritance of darker colour character acquired due to the darker environment
- (2) Natural selection whereby the darker forms were selected.
- (3) Appearance of the darker coloured individuals due to very poor sunlight

(4)Protective mimicry

**Q.125** Sickel cell anemia is :

- (1) Characterized by elongated sickle like RBCs with a nucleus
- (2) An autosomal linked dominant trait
- (3) Caused by substitute of valine by glutamic acid in the beta globin chain of haemoglobin
- (4) Caused by a change in a single base pair of DNA

**Q.126** Study the pedigree chart given below :

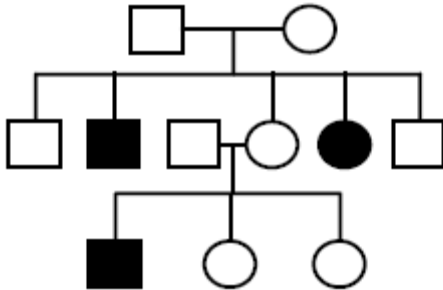

What does it show ?

- (1) Inheritance of a recessive sex-linked disease like haemophilia
- (2) Inheritance of a sex-linked inborn error of metabolism like phenylketonuria
- (3) Inheritance of a condition like phenylketonuria as an autosomal recessive trait
- (4) The pedigree chart is wrong as this is not Possible\

**Q.127** The most popularly known blood grouping is the ABO grouping. It is named ABO and not ABC, because "O" in it refers to having :

- (1) No antigens A and B on RBCs
- (2) Other antigens besides A and B on RBCs
- (3) Over dominance of this type on the genes for A and B types
- (4) One antibody only-either anti-A and anti-B on the RBCs

**Q.128** Select the incorrect statement from the following :

- (1) Baldness is a sex limited trait
- (2) Linkage is an exception to the principle of independent assortment in heredity
- (3) Galactosemia is an inborn error of Metabolism
- (4) Small population size results in random genetic drift in a population

**Q.129** Cotyledons and test respectively are edible parts in –

- (1) Cashew nut and litchi
- (2) Groundnut and pomegranate
- (3) Walnut and tamarind
- (4) French bean and coconut

**Q.130** An example of a seed with endosperm, perisperm and caruncle is –

- |            |            |
|------------|------------|
| (1) Castor | (2) Cotton |
| (3) Coffee | (4) Lily   |

**Q.131** Guard cells help in :

- (1) Fighting against infection
- (2) Protection against grazing
- (3) Transpiration
- (4) Guttation

**Q.132** Manganese is required in :

- (1) Chlorophyll synthesis
- (2) Nucleic acid synthesis
- (3) Plant cell wall formation
- (4) Photolysis of water during photosynthesis
- (5)

**Q.133** Oxygenic photosynthesis occurs in :

- (1) *Chlorobium*                      (2) *Chromatium*  
(3) *Oscillatoria*                      (4) *Rhodospirillum*

**Q.134** A fruit developed from hypanthodium inflorescence is called :

- (1) Caryopsis                      (2) Hesperidium  
(3) Sorosis                      (4) Syconus

**Q.135** The annular and spirally thickened conducting elements generally develop in the protoxylem when the root or stem is –

- (1) Differentiating  
(2) Maturing  
(3) Elongating  
(4) Widening

**Q.136** The floral formula  $+ K_{(5)} C_{(5)} A_5 G_{(2)}$  is that of :

- (1) Tobacco (2) Tulip  
(3) Soybean                      (4) Sunnhemp

**Q.137** An example of axile placentation is –

- (1) Marigold (2) *Argemone*  
(3) *Dianthus* (4) Lemon

**Q.138** In barley stem vascular bundles are –

- (1) Closed and radial (2) Open and scattered  
(3) Closed and scattered (4) Open and in a ring

**Q.139** Aerobic respiratory pathway is appropriately termed :-

- (1) Anabolic (2) Catabolic  
(3) Parabolic (4) Amphibolic

**Q.140** Palisade parenchyma is absent in leaves of –

- (1) Gram (2) Sorghum
- (3) Mustard (4) Soybean

**Q.141** Reduction in vascular tissue, mechanical tissue and cuticle is characteristic of :

- (1) Hydrophytes (2) Xerophytes
- (3) Mesophytes (4) Epiphytes

**Q.142** Anatomically fairly old dicotyledonous root is distinguished from the dicotyledonous stem by :

- (1) Position of protoxylem
- (2) absence of secondary xylem
- (3) Absence of secondary phloem
- (4) Presence of cortex

**Q.143** Cyclic photophosphorylation results in the formation of :

- (1) ATP
- (2) NADPH
- (3) ATP and NADPH
- (4) ATP, NADPH and O<sub>2</sub>

**Q.144** In a standard ECG which one of the following alphabets is the correct representation of the respective activity of the human heart ?

- (1) P-depolarisation of the atria
- (2) R-repolarisation of ventricles
- (3) S-start of systole
- (4) T-end of diastole

**Q.145** Uric acid is the chief nitrogenous component of the excretory products of –

- (1) Frog (2) Man
- (3) Earthworm (4) Cockroach

**Q.146** Which one of the following pairs of food compounds in humans reaches the stomach totally undigested –



- (1) Starch and cellulose                      (2) Protein and starch  
(3) Starch and fat                              (4) Fat and cellulose

**Q.147** Which one of the following is correct pairing of a body part and like kind of muscle tissue that moves it ?

- (1) Iris – Involuntary smooth muscle  
(2) Heart wall – Involuntary unstriated muscle  
(3) Biceps of upper arm – smooth muscle fibres  
(4) Abdominal wall – smooth muscle

**Q.148** Compared to blood our lymph has :

- (1) More RBCs and less WBCs  
(2) No plasma  
(3) Plasma without proteins  
(4) More WBCs and no RBCs

**Q.149** What will happen if the stretch receptors of the urinary bladder wall are totally removed ?

- (1) There will be no micturition  
(2) Urine will continue to collect normally in bladder  
(3) Micturition will continue  
(5) Urine will not collect in the bladder

**Q.150** Which part of human brain is concerned with the regulation of body temperature ?

- (1) Hypothalamus  
(2) Medulla Oblongata  
(3) Cerebellum  
(4) Cerebrum

**Q.151** a young infant may be feeding entirely on mother's milk which is white in colour but the stools which the infant passes out is quite yellowish. What is this yellow colour due to ?

- (1) Pancreatic juice poured into duodenum
- (2) Intestinal juice
- (3) Bile pigments passed through bile juice
- (4) Undigested milk protein casein

**Q.152** Globulins contained in human blood plasma are primarily involved in –

- (1) Clotting of blood
- (2) Defence mechanisms of body
- (3) Osmotic balance of body fluids
- (4) Oxygen transport in the blood

**Q.153** Seminal plasma in humans is rich in :

- (1) Fructose and certain enzymes but poor Calcium
- (2) Fructose and calcium but has no enzyme
- (3) Fructose, calcium and certain enzymes
- (4) Glucose and certain enzymes but has no Calcium

**Q.154** Given below is a diagrammatic sketch for a portion of human male reproductive system. Select the correct set of the names of the parts labelled A, B, C, D.

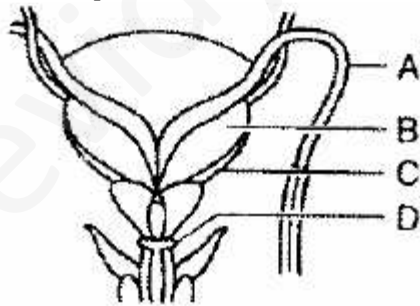

A                      B                      C                      D

- (1) Ureter Seminal vesicle Prostate Bulbourethral gland
- (2) Ureter Prostate Seminal vesicle Bulbourethral gland
- (3) Vas deferens Seminal vesicle Prostate Bulbourethral gland
- (4) Vas deferens Seminal vesicle Bulbourethral gland Prostate

**Q.155** Which one of the following is the correct matching of three items and their grouping category ? Items Groups

- (1) Cytosine, uracil, thiamine Pyrimidines
- (2) Malleus, incus, cochlea Ear ossicles
- (3) ilium, ischium pubis Coxal bones of pelvic girdle
- (4) Actin, myosin, rhodopsin Muscle proteins

**Q.156** Which one of the following statement is true regarding digestion and absorption of food in humans :

- (1) About 60% of starch is hydrolysed by salivary amylase in our mouth
- (2) Oxyntic cells in our stomach secrete the proenzyme pepsinogen
- (3) Fructose and amino acids are absorbed through intestinal mucosa with the help of carrier ions like Na<sup>+</sup>
- (4) Chylomicrons are small lipoprotein particles that are transported from intestine into blood capillaries

**Q.157** Which one of the following correctly described the location of some body parts in the earthworm *Pheretima* ?

- (1) Two pairs of accessory glands in 16–18 segments
- (2) Two pairs of testes in 10<sup>th</sup> and 11<sup>th</sup> segments
- (3) Four pairs of spermathecae in 4–7 segments
- (4) One pair of ovaries attached at inter segmental septum of 14<sup>th</sup> and 15<sup>th</sup> segments.

**Q.158** Elbow joint is an example of :

- (1) Ball and socket joint
- (2) Pivot joint
- (3) Hinge joint
- (4) Gliding joint

**Q.159** Which one of the following is considered important in the development of seed habit ?

- (1) Free-living gametophyte
- (2) Dependent sporophyte
- (3) Heterospory
- (4) Haplontic life cycle

**Q.160** One of the synthetic auxin is :

- (1) IBA (2) NAA (3) IAA (4) GA

**Q.161** Which one of the following acids is a derivative of carotenoids ?

- (1) Abscisic acid (2) Indole butyric acid  
(3) Indole-3-acetic acid (4) Gibberellic acid

**Q.162** Vegetative propagation in mint occurs by :

- (1) Sucker (2) Runner  
(3) Offset (4) Rhizome

**Q.163** Which one of the following plants is monoecious ?

- (1) *Papaya* (2) *Marchantia*  
(3) *Pinus* (4) *Cycas*

**Q.164** Foetal ejection reflex in human female is induced by

- (1) Differentiation of mammary glands  
(2) Pressure exerted by amniotic fluid  
(3) Release of oxytocin from pituitary  
(4) Fully developed foetus and placenta

**Q.165** Which of the following is the correct matching of the events occurring during menstrual cycle ?

- (1) Menstruation Breakdown of myometrium and ovum not fertilized  
(2) Ovulation LH and FSH attain peak level and sharp fall in the secretion of progesterone  
(3) Proliferative phase Rapid regeneration of myometrium and maturation of Graafian follicle  
(4) Development of corpus luteum Secretory phase and increased secretion of progesterone.

**Q.166** Which one of the following is the most likely root cause why menstruation is not taking place in regularly cycling human female ?

- (1) Retention of well-developed corpus luteum

- (2) Fertilization of the ovum
- (3) Maintenance of the hypertrophical endometrial lining
- (4) Maintenance of high concentration of sex hormones in the blood stream

**Q.167** The correct sequence of spermatogenetic stages leading to the formation of sperms in a mature human testis is :

- (1) Spermatogonia-spermatid-spermatocytesperms
- (2) Spermatocyte-spermatogonia-spermatidsperms
- (3) Spermatogonia-spermatocyte-spermatidsperms
- (4) Spermatid-spermatocyte-spermatogoniasperms

**Q.168** A change in the amount of yolk and its distribution in the egg will effect :

- (1) Fertilization
- (2) Formation of zygote
- (3) Pattern of cleavage
- (4) Number of blastomeres produced

**Q.169** When breast feeding is replaced by less nutritive food low in proteins and calories, the infants below the age of one year are likely to suffer from :

- (1) Pellagra                      (2) Marasmus
- (3) Rickets                        (4) Kwashiorkor

**Q.170** Which one of the following types organisms occupy more than one trophic level in a pond ecosystem ?

- (1) Frog                            (2) Phytoplankton
- (3) Fish                            (4) Zooplankton

**Q.171** Which one of the following has maximum genetic diversity in India ?

- (1) Tea                              (2) Teak
- (3) Mango                        (4) Wheat

**Q.172** Montreal protocol aims at :

- (1) Control of CO<sub>2</sub> emission
- (2) Reduction of ozone depleting substances
- (3) Biodiversity conservation
- (4) Control of water pollution

**Q.173** Chipko movement was launched for the protection of –

- (1) Wet lands (2) Grasslands
- (2) Forests (4) Livestock

**Q.174** The correct sequence of plants in hydrosere is :

- (1) Oak → Lantana → Volvox → Hydrilla → Pistia → Scirpus
- (2) Oak → Lantana → Scirpus → Pistia → Hydrilla → Volvox
- (3) Volvox → Hydrilla → Pistia → Scirpus → Lantana → Oak
- (4) Pistia → Volvox → Scirpus → Hydrilla → Oak → Lantana

**Q.175** A country with a high rate of population growth took measures to reduce it. The figure below shows age-sex pyramids of populations A and B twenty years apart. Select the correct interpretation about them : –

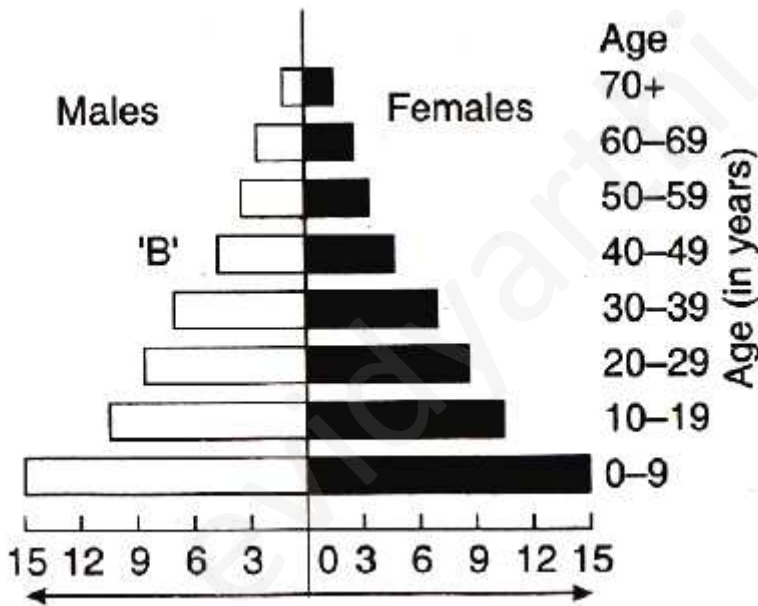
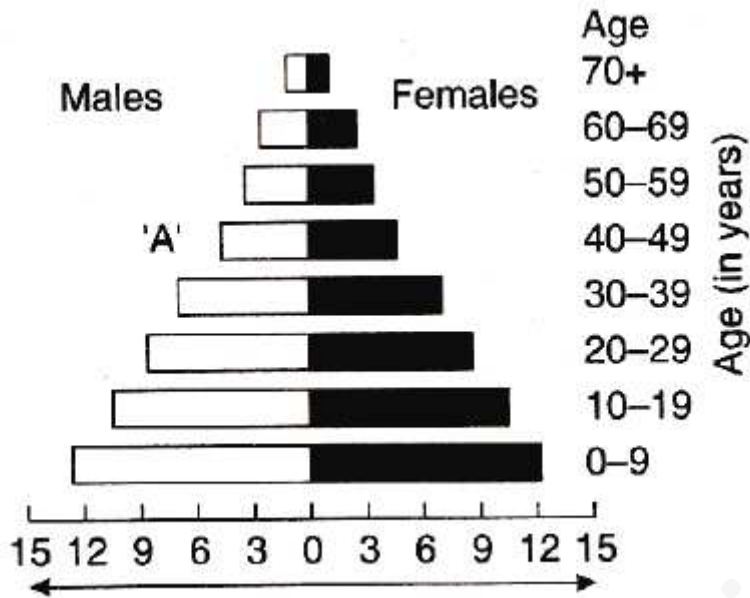

- (1) "A" is the earlier pyramid and no change has occurred in the growth rate
- (2) "A" is more recent shows slight reduction in the growth rate
- (3) "B" is earlier pyramid and shows stabilized growth rate
- (4) "B" is more recent showing that population is very young

**Q.176** Step taken by the Government of India to control air pollution include :

- (1) Use of non-polluting Compressed Natural Gas (CNG) only as fuel by all buses and Trucks
- (2) Compulsory mixing of 20% ethyl alcohol with petrol and 20% biodiesel with diesel
- (3) Compulsory PUC (Pollution Under Control) certification of petrol driven vehicles which tests for carbon monoxide and hydrocarbons
- (4) Permission to use only pure diesel with a maximum of 500 ppm sulphur as fuel for vehicles

**Q.177** Biochemical Oxygen Demand (BOD) in a river water :

- (1) Increases when sewage gets mixed with river water
- (2) Remains unchanged when algal bloom Occurs
- (3) has no relationship with concentration of oxygen in the water
- (4) Gives a measure of Salmonella in the water

**Q.178** DDT residues are rapidly passed through food chain causing biomagnification because DDT is :

- (1) Water soluble
- (2) Lipo soluble
- (3) Moderately toxic
- (4) Non-toxic to aquatic animals

**Q.179** Global agreement in specific control strategies to reduce the release of ozone depleting substances, was adopted by :

- (1) The Vienna Convention
- (2) Rio de Janeiro Conference
- (3) The Montreal Protocol
- (4) The Kyoto Protocol

**Q.180** Somaclones are obtained by : -

- (1) Genetic engineering
- (2) Tissue culture



- (3) Plant breeding
- (4) Irradiation Genetic engineering

**Q.181** Which one is the wrong pairing for the disease and its causal organism ?

- (1) Root-knot of vegetables : *Meloidogyne* sp
- (2) Late blight of potato : *Alternaria solani*
- (3) Black rust of wheat : *Puccinia graminis*
- (4) Loose smut of wheat : *Ustilago nuda*

**Q.182** Which of the following is not used as a biopesticide ?

- (1) *Xanthomonas Campestris*
- (2) *Bacillus thuringiensis*
- (3) *Trichoderma harzianum*
- (4) Nuclear Polyhedral Virus (NPV)

**Q.183** Which of the following plant species you would select for the production of bioethanol ?

- (1) *Jatropha* (2) *Brassica*
- (3) *Zea Mays* (4) *Pongamia*

**Q.184** Which of the following is a symbiotic nitrogen fixer ?

- (1) *Azolla* (2) *Glomus*
- (3) *Azotobacter* (4) *Frankia*

**Q.185** A health disorder that results from the deficiency of thyroxine in adults and characterized by (i) a low metabolic rate (ii) increase in body weight and (iii) tendency to retain water in tissues is :

- (1) Cretinism (2) Hypothyroidism
- (3) Simple goiter (4) Myxoedema

**Q.186** Which one of the following statement is correct ?

- (1) Malignant tumours may exhibit metastasis
- (2) Patients who have undergone surgery are given cannabinoids to relieve pain.

(3) Benign tumours show the property of  
Metastasis

(4) Heroin accelerates body functions.

**Q.187** Which of following is a pair of viral diseases ?

(1) Typhoid, Tuberculosis

(2) Ringworm, AIDS

(3) Common Cold, AIDS

(4) Dysentery, Common Cold

**Q.188** A person likely to develop tetanus is immunized by administering :

(1) Weakened germs

(2) Dead germs

(3) Preformed antibodies

(4) Wide spectrum antibiotics

**Q.189** Use of anti-histamines and steroids give a quick relief from –

(1) Headache                      (2) Allergy

(3) Nausea                         (4) Cough

**Q.190** Alzheimer disease in humans is associated with the deficiency of :

(1) Gamma aminobutyric acid (GABA)

(2) Dopamine

(3) Glutamic acid

(4) Acetylcholine

**Q.191** which one of the following is commonly used in transfer of foreign DNA into crop plants ?

(1) *Penicillium expansum*

(2) *Trichoderma harzianum*

(3) *Meloidogyne incognita*

(4) *Agrobacterium tumefaciens*

**Q.192** The bacterium *Bacillus thuringiensis* is widely used in contemporary biology as –

- (1) Source of industrial enzyme
- (2) Indicator of water pollution
- (3) Insecticide
- (4) Agent for production of dairy products

**Q.193** Which one of the following pairs is wrongly matched ?

- (1) Textile – amylase
- (2) Detergents – lipase
- (3) Alcohol – nitrogenase
- (4) Fruit juice – pectinase

**Q.194** Polyethylene glycol method is used for :

- (1) Energy production from sewage
- (2) Gene transfer without a vector
- (3) Biodiesel production
- (4) Seedless fruit production

**Q.195** Transgenic plants are the ones –

- (1) Grown in artificial medium after hybridization in the field
- (2) Produced by a somatic embryo in artificial medium
- (3) Generated by introducing foreign DNA in to a cell and regenerating a plant from that cell
- (4) Produced after protoplast fusion in artificial medium

**Q.196** What is true about Bt toxin ?

- (1) The concerned *Bacillus* has antitoxins
- (2) The inactive protoxin gets converted into active form in the insect gut
- (3) Bt protein exists as active toxin in the *Bacillus*

(4) The activated toxin enters the ovaries of the pest to sterillise it and thus prevent its multiplication.

**Q.197** The genetic defect-adenosine deaminase (ADA) deficiency may be cured permanently by

- (1) Enzyme replacement therapy
- (2) Periodic infusion of genetically engineered lymphocytes having functional ADA cDNA
- (3) Administering adenosine deaminase activators
- (4) Introducing bone marrow cells producing ADA into cells at early embryonic stages

**Q.198** There is no DNA in :

- (1) Hair root
- (2) An enucleated ovum
- (3) Mature RBCs
- (4) A mature spermatozoan

**Q.199** The letter T in T-lymphocyte refers to :

- (1) Thymus (2) Thyroid
- (3) Thalamus (4) Tonsil

**Q.200** Tiger is not a resident in which one of the following National Park ?

- (1) Jim Corbett (2) Ranthambhor
- (3) Sunderbans (4) Gir