

AIPMT Main 2011 (Questions)

Q.1 The density of a material in CGS system of units is 4 g/cm^3 . In a system of units in which unit of length is 10 cm and unit of mass is 100g, the value of density of material will be

- (1) 0.04 (2) 0.4
(3) 40 (4) 400

Q.2 A particle covers half of its total distance with speed v_1 and the rest half distance with speed v_2 . Its average speed during the complete journey is :

- (1) $\frac{v_1 + v_2}{2}$ (2) $\frac{v_1 v_2}{v_1 + v_2}$
(3) $\frac{2v_1 v_2}{v_1 + v_2}$ (4) $\frac{v_1^2 v_2^2}{v_1^2 + v_2^2}$

Q.3 A mass m moving horizontally (along the x-axis) with velocity v collides and sticks to a mass of $3m$ moving vertically upward (along the y-axis) with velocity $2v$. The final velocity of the combination is :

- (1) $\frac{3}{2}v\hat{i} + \frac{1}{4}v\hat{j}$ (2) $\frac{1}{4}v\hat{i} + \frac{3}{2}v\hat{j}$
(3) $\frac{1}{3}v\hat{i} + \frac{2}{3}v\hat{j}$ (4) $\frac{2}{3}v\hat{i} + \frac{1}{3}v\hat{j}$

Q.4 A conveyor belt is moving at a constant speed of 2 m/s. A box is gently dropped on it. The coefficient of friction between them is $\mu = 0.5$. The distance that the box will move relative to belt before coming to rest on it, taking $g = 10 \text{ ms}^{-2}$ is

- (1) 0.4 m (2) 1.2 m
(3) 0.6 m (4) Zero

Q.5 A small mass attached to a string rotates on a frictionless table top as shown. If the tension in the string is increased by pulling the string causing the radius of the circular motion to decrease by a factor of 2, the kinetic energy of the mass will

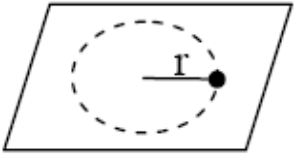

- (1) decrease by a factor of 2
- (2) remain constant
- (3) increase by a factor of 2
- (4) increase by a factor of 4

Q.6 A particle of mass m is thrown upwards from the surface of the earth, with a velocity u . The mass and the radius of the earth are, respectively, M and R . G is gravitational constant and g is acceleration due to gravity on the surface of the earth. The minimum value of u so that the particle does not return back to earth is :

- (1) $\sqrt{\frac{2GM}{R^2}}$
- (2) $\sqrt{\frac{2GM}{R}}$
- (3) $\sqrt{\frac{2gM}{R^2}}$
- (4) $\sqrt{2gR^2}$

Q.7 A particle of mass M is situated at the centre of a spherical shell of same mass and radius a . The magnitude of the gravitational potential at a point situated at $a/2$ distance from the centre, will be :

- (1) $\frac{GM}{a}$
- (2) $\frac{2GM}{a}$
- (3) $\frac{3GM}{a}$
- (4) $\frac{4GM}{a}$

Q.8 A projectile is fired at an angle of 45° with the horizontal. Elevation angle of the projectile at its highest point as seen from the point of projection, is :

- (1) 45°
- (2) 60°

- (3) $\tan^{-1} \frac{1}{2}$
- (4) $\tan^{-1} \left(\frac{\sqrt{3}}{2} \right)$

Q.9 A mass of diatomic gas ($\gamma = 1.4$) at a pressure of 2 atmospheres is compressed adiabatically so that its temperature rises from 27°C to 927°C . The pressure of the gas in the final state is

- (1) 8 atm (2) 28 atm
(3) 68.7 atm (4) 256 atm

Q.10 Two particles are oscillating along two close parallel straight lines side by side, with the same frequency and amplitudes. They pass each other, moving in opposite directions when their displacement is half of the amplitude. The mean positions of the two particles lie on a straight line perpendicular to the paths of the two particles. The phase difference is :

- (1) $\pi/6$ (2) 0
(3) $2\pi/3$ (4) π

Q.11 Two identical piano wires, kept under the same tension T have a fundamental frequency of 600Hz. The fractional increase in the tension of one of the wires which will lead to occurrence of 6 beats / s when both the wires oscillate together would be :

- (1) 0.01 (2) 0.02
(3) 0.03 (4) 0.04

Q.12 A thin prism of angle 15° made of glass of refractive index $\mu_1 = 1.5$ is combined with another prism of glass of refractive index $\mu_2 = 1.75$. The combination of the prism produced dispersion without deviation. The angle of the second prism should be :

- (1) 5° (2) 7°
(3) 10° (4) 12°

Q.13 A converging beam of rays is incident on a diverging lens. Having passed through the lens the rays intersect at a point 15 cm from the lens on the opposite side. If the lens is removed the point where the rays meet will move 5 cm closer to the lens. The focal length of the lens is :

- (1) 5 cm (2) -10 cm

- (3) 20 cm (4) – 30 cm

Q.14 Three charges, each +q, are placed at the corners of an isosceles triangle ABC of sides BC and AC, 2a. D and E are the mid points of BC and CA. The work done in taking a charge Q from D to E is :

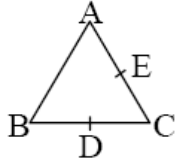

- (1) $\frac{3qQ}{4\pi\epsilon_0 a}$ (2) $\frac{3qQ}{8\pi\epsilon_0 a}$
(3) $\frac{qQ}{4\pi\epsilon_0 a}$ (4) zero

Q.15 The electric potential V at any point (x, y, z), all in meters in space is given by $V = 4x^2$ volt. The electric field at the point (1, 0, 2) in volt/meter, is :

- (1) 8 along negative X-axis
(2) 8 along positive X-axis
(3) 16 along negative X-axis
(4) 16 along positive X-axis

Q.16 In the circuit shown in the figure, if the potential at point A is taken to be zero, the potential at point B is

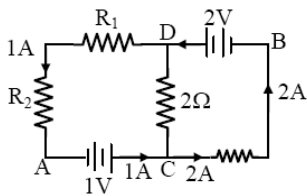

- (1) +1 V (4) – 2 V
(3) +2 V

Q.17 A galvanometer of resistance, G , is shunted by a resistance S ohm. To keep the main current in the circuit unchanged the resistance to be put in series with the galvanometer is

- (1) $\frac{G}{(S+G)}$ (2) $\frac{S^2}{(S+G)}$
 (3) $\frac{SG}{(S+G)}$ (4) $\frac{G^2}{(S+G)}$

Q.18 A thermocouple of negligible resistance produces an e.m.f. of $40 \mu\text{V}/^\circ\text{C}$ in the linear range of temperature. A galvanometer of resistance 10 ohm whose sensitivity is $1 \mu\text{A}/\text{division}$, is employed with the thermocouple. The smallest value of temperature difference that can be detected by the system will be

- (1) 0.25°C (2) 0.5°C
 (3) 1°C (4) 0.1°C

Q.19 Charge q is uniformly spread on a thin ring of radius R . The ring rotates about its axis with a uniform frequency f Hz. The magnitude of magnetic induction at the center of the ring is

- (1) $\frac{\mu_0 q f}{2\pi R}$ (2) $\frac{\mu_0 q f}{2R}$
 (3) $\frac{\mu_0 q}{2fR}$ (4) $\frac{\mu_0 q}{2\pi fR}$

Q.20 A short bar magnet of magnet moment 0.4 JT^{-1} is placed in a uniform magnetic field of 0.16 T . The magnet is in stable equilibrium when the potential energy is :

- (1) 0.064 J (2) -0.064 J
 (3) Zero (4) -0.082 J

Q.21 A square loop, carrying a steady current I , is placed in a horizontal plane near a long straight conductor carrying a steady current I_1 at a distance d from the conductor as shown in figure. The loop will experience:

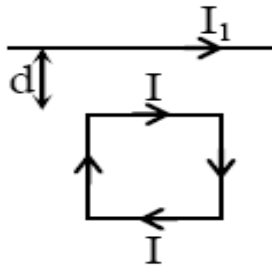

- (1) a net attractive force towards the conductor
- (2) a net repulsive force away from the conductor
- (3) a net torque acting upward perpendicular to the horizontal plane
- (4) a net torque acting downward normal to the horizontal plane

Q.22 The r.m.s. value of potential difference V shown in the figure is :

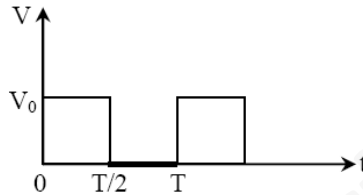

- (1) $V_0/3$
- (2) V_0
- (3) $V_0/2$
- (4) $V_0/2$

Q.23 A coil has resistance 30 ohm and inductive reactance 20 Ohm at 50 Hz frequency. If an ac source, of 200 volt, 100 Hz, is connected across the coil, the current in the coil will be

- (1) 2.0 A
- (2) 4.0 A
- (3) 8.0 A
- (4) $\frac{20}{\sqrt{13}}$ A

Q.29 In the following figure, the diodes which are forward biased are :

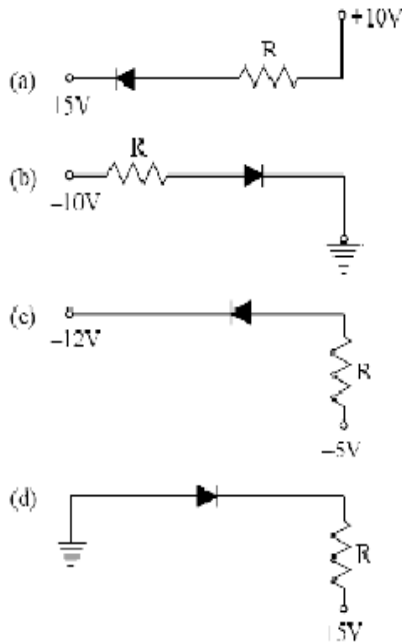

- (1) (a), (b) and (d)
- (2) (c) only
- (3) (c) and (a)
- (4) (b) and (d)

Q.30 Pure Si at 500 K has equal number of electron (n_e) and hole (n_h) concentrations of $1.5 \times 10^{16} \text{ m}^{-3}$. Doping by indium increases n_h to $4.5 \times 10^{22} \text{ m}^{-3}$. The doped semiconductor is of :

- (1) P-type having electron concentrations $n_e = 5 \times 10^9 \text{ m}^{-3}$
- (2) n-type with electron concentrations $n_e = 5 \times 10^{22} \text{ m}^{-3}$
- (3) P-type with electron concentrations $n_e = 2.5 \times 10^{10} \text{ m}^{-3}$
- (4) n-type with electron concentrations $n_e = 2.5 \times 10^{23} \text{ m}^{-3}$

Q.31 The unit of rate constant for a zero order reaction is -

- (1) s^{-1}
- (2) $\text{mol L}^{-1} \text{s}^{-1}$
- (3) $\text{L mol}^{-1} \text{s}^{-1}$
- (4) $\text{L}^2 \text{mol}^{-2} \text{s}^{-1}$

Q.32 The half life of a substance in a certain enzymecatalysed reaction is 138 s. The time required for the concentration of the substance to fall from 1.28 mg L^{-1} to 0.04 mg L^{-1} , is-

- (1) 276 s
- (2) 414 s

(3) 552 s (4) 690 s

Q.33 Consider the following processes : ΔH (kJ/mol)



For $B + D \rightarrow E + 2C$, ΔH will be-

- (1) 325 kJ/mol (2) 525 kJ/mol
(3) -175 kJ/mol (4) -325 kJ/mol

Q.34 The pairs of species of oxygen and their magnetic behaviors are noted below. Which of the following presents the correct description?

- (1) O , O_2 - Both paramagnetic
(2) O , O_2 - Both diamagnetic
(3) O , O_2 - Both paramagnetic
(4) O , O_2 - Both paramagnetic

Q.35 According to the Bohr Theory, which of the following transitions in the hydrogen atom will give rise to the least energetic photon?

- (1) $n = 5$ to $n = 3$
(2) $n = 6$ to $n = 1$
(3) $n = 5$ to $n = 4$
(4) $n = 6$ to $n = 5$

Q.36 In qualitative analysis, the metals of Group I can be separated from other ions by precipitating them as chloride salts. A solution initially contains Ag^+ and Pb^{2+} at a concentration of 0.10 M. Aqueous HCl is added to this solution until the Cl^- concentration is 0.10 M. What will the concentration of Ag^+ and Pb^{2+} be at equilibrium?

(K_{sp} for $AgCl = 1.8 \times 10^{-10}$,
 K_{sp} for $PbCl_2 = 1.7 \times 10^{-5}$)

- (1) $[Ag^+] = 1.8 \times 10^{-11}M$;
 $[Pb^{2+}] = 1.7 \times 10^{-4}M$
(2) $[Ag^+] = 1.8 \times 10^{-7}M$;
 $[Pb^{2+}] = 1.7 \times 10^{-6}M$
(3) $[Ag^+] = 1.8 \times 10^{-11}M$;

$$[\text{Pb}^{2+}] = 8.5 \times 10^{-5} \text{M}$$

$$(4) [\text{Ag}^+] = 1.8 \times 10^{-9} \text{M};$$

$$[\text{Pb}^{2+}] = 1.7 \times 10^{-3} \text{M}$$

Q.37 A bubble of air is underwater at temperature 15°C and the pressure 1.5 bar. If the bubble rises to the surface where the temperature is 25°C and the pressure is 1.0 bar, what will happen to the volume of the bubble?

- (1) Volume will become greater by a factor of 2.5
- (2) Volume will become greater by a factor of 1.6
- (3) Volume will become greater by a factor of 1.1
- (4) Volume will become smaller by a factor of 0.70

Q.38 A 0.1 molal aqueous solution of a weak acid is 30% ionized. If K_f for water is $1.86^\circ\text{C}/\text{m}$, the freezing point of the solution will be -

- (1) -0.24°C (2) -0.18°C
- (3) -0.54°C (4) -0.36°C

Q.39 A solution contains Fe^{2+} , Fe^{3+} and I^- ions. This solution was treated with iodine at 35°C . E° for $\text{Fe}^{3+}/\text{Fe}^{2+}$ is $+0.77 \text{ V}$ and E° for $\text{I}_2/2\text{I}^- = 0.536 \text{ V}$. The favorable redox reaction is-

- (1) Fe^{2+} will be oxidized to Fe^{3+}
- (2) I_2 will be reduced to I^-
- (3) There will be no redox reaction
- (4) I^- will be oxidized to I_2

Q.40 The rate of the reaction $2\text{N}_2\text{O}_5 \rightarrow 4\text{NO}_2 + \text{O}_2$ can be written in three ways:

$$\frac{-d[\text{N}_2\text{O}_5]}{dt} = k[\text{N}_2\text{O}_5]$$

$$\frac{d[\text{NO}_2]}{dt} = k'[\text{N}_2\text{O}_5]$$

$$\frac{d[\text{O}_2]}{dt} = k''[\text{N}_2\text{O}_5]$$

The relationship between k and k' and between k and k'' are-

- (1) $k' = k$, $k'' = k$
- (2) $k' = 2k$; $k'' = k$

- (3) $k' = 2k$, $k'' = k/2$ (4) $k' = 2k$; $k'' = 2k$

Q.41 200 mL of an aqueous solution of a protein contains its 1.26 g. The Osmotic pressure of this solution at 300 K is found to be 2.57×10^{-3} bar. The molar mass of protein will be ($R = 0.083$ L bar mol⁻¹ K⁻¹):

- (1) 61038 g mol⁻¹ (2) 51022 g mol⁻¹
 (3) 122044 g mol⁻¹ (4) 31011 g mol⁻¹

Q.42 Match List I with List II for the compositions of substances and select the correct answer using the code given below the lists-

List-I Substances		List-II Composition	
(A)	Plaster of paris	(i)	CaSO ₄ . 2H ₂ O
(B)	Epsomite	(ii)	CaSO ₄ . ½H ₂ O
(C)	Kieserite	(iii)	MgSO ₄ . 7H ₂ O
(D)	Gypsum	(iv)	MgSO ₄ . H ₂ O
		(v)	CaSO ₄

Code :

- | | | | | |
|-----|------------|------------|------------|------------|
| | (A) | (B) | (C) | (D) |
| (1) | (iv) | (iii) | (ii) | (i) |
| (2) | (iii) | (iv) | (i) | (ii) |
| (3) | (ii) | (iii) | (iv) | (i) |
| (4) | (i) | (ii) | (iii) | (v) |

Q.43 Which of the following oxide is amphoteric?

- (1) CO₂ (2) SnO₂
 (3) CaO (4) SiO₂

Q.44 The following reactions take place in the blast furnace in the preparation of impure iron. Identify the reaction pertaining to the formation of the slag.

- (1) $2C(s) + O_2(g) \rightarrow 2CO(g)$
 (2) $Fe_2O_3(s) + 3CO(g) \rightarrow 2Fe(l) + 3CO_2(g)$
 (3) $CaCO_3(s) \rightarrow CaO(s) + CO_2(g)$
 (4) $CaO(s) + SiO_2(s) \rightarrow CaSiO_3(s)$

Q.45 Which of the following statements is incorrect?

- (1) NaHCO_3 on heating gives Na_2CO_3
- (2) Pure sodium metal dissolves in liquid ammonia to give blue solution.
- (3) NaOH reacts with glass to give sodium silicate
- (4) Aluminium reacts with excess NaOH to give Al(OH)_3

Q.46 What is the value of electron gain enthalpy of Na^+ if IE_1 of $\text{Na} = 5.1 \text{ eV}$?

- (1) $+ 10.2 \text{ eV}$ (2) -5.1 eV
- (3) -10.2 eV (4) $+ 2.55 \text{ eV}$

Q.47 Which has the maximum number of molecules among the following?

- (1) 64 g SO_2 (2) 44 g CO_2
- (3) 48 g O_3 (4) 8 g H_2

Q.48 A solid compound XY has NaCl structure. If the radius of the cation is 100 pm , the radius of the anion (Y^-) will be-

- (1) 165.7 pm (2) 275.1 pm
- (3) 322.5 pm (4) 241.5 pm

Q.49 Which of the following structures is the most preferred and hence of lowest energy for SO_3 ?

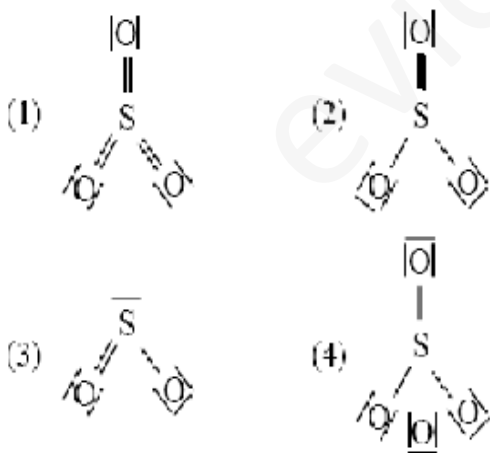

Q.50 Which of the following carbonyls will have the strongest C-O bond ?

- (1) Fe(CO)_5 (2) Mn(CO)_6

+
(3) $\text{Cr}(\text{CO})_6$ (4) $\text{V}(\text{CO})_6$

Q.51 Which of the following complex compounds will exhibit highest paramagnetic behaviour?

- (1) $[\text{Zn}(\text{NH}_3)_6]^{2+}$ (2) $[\text{Ti}(\text{NH}_3)_6]^{3+}$
(3) $[\text{Cr}(\text{NH}_3)_6]^{3+}$ (4) $[\text{Co}(\text{NH}_3)_6]^{3+}$
(At. No. Ti = 22, Cr = 24, Co = 27, Zn = 30)

Q.52 Which of the following compounds is most basic ?

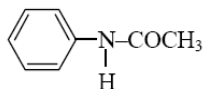
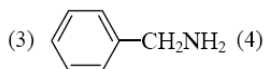
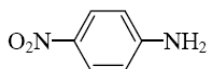
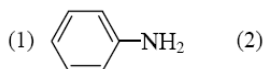

Q.53 Which of the following is not a fat soluble vitamin ?

- (1) Vitamin A (2) Vitamin B complex
(3) Vitamin D (4) Vitamin E

Q.54 Which of the following compounds undergoes nucleophilic substitution reaction most easily ?

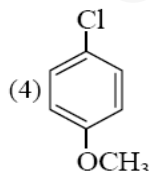
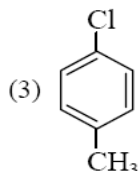
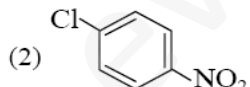
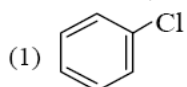

Q.55 The IUPAC name of the following compound

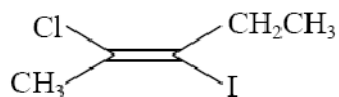

is -

- (1) cis-2-chloro-3-iodo-2-pentene
- (2) trans-2-chloro-3-iodo-2-pentene
- (3) cis-3-iodo-4-chloro-3-pentene
- (4) trans-3-iodo-4-chloro-3-pentene

Q.56 An organic compound 'A' on treatment with NH_3 gives 'B', which on heating gives 'C'. 'C' when treated with Br_2 in the presence of KOH produces ethylamine. Compound 'A' is -

- (1) $\text{CH}_3\text{CH}_2\text{COOH}$
- (2) CH_3COOH
- (3) $\text{CH}_3\text{CH}_2\text{CH}_2\text{COOH}$
- (4) $\text{CH}_3-\underset{\text{CH}_3}{\text{CH}}\text{COOH}$

Q.57 Match the compounds given in List-I with List-II and select the suitable option using the code given below :

List-I		List-II	
(a)	<i>Benzaldehyde</i>	(i)	Phenolphthalein
(b)	<i>Phthalic anhydride</i>	(ii)	Benzoin condensation
(c)	<i>Phenyl benzoate</i>	(iii)	Oil of wintergreen
(d)	Methyl salicylate	(iv)	Fries rearrangement

Code :

- | | | | |
|------------|------------|------------|------------|
| (a) | (b) | (c) | (d) |
| (1) (ii) | (i) | (iv) | (iii) |
| (2) (iv) | (i) | (iii) | (ii) |
| (3) (iv) | (ii) | (iii) | (i) |
| (4) (ii) | (iii) | (iv) | (i) |

Q.58 Which of the statements about "Denaturation" given below are correct ?

Statements

- (a) Denaturation of proteins causes loss of secondary and tertiary structures of the protein
- (b) Denaturation leads to the conversion of double strand of DNA into single strand
- (c) Denaturation affects primary structure which gets distorted

Options :

- (1) (a), (b) and (c)
- (2) (b) and (c)
- (3) (a) and (c)
- (4) (a) and (b)

Q.59 The order of reactivity of phenyl magnesium bromide (PhMgBr) with the following compounds :

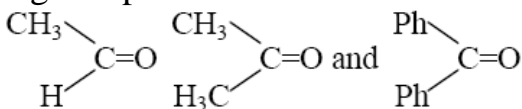

- I
II
III
- (1) I > II > III (2) III > II > I
 (3) II > I > III (4) I > III > II

Q.60 Consider the reactions :

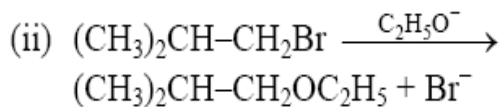
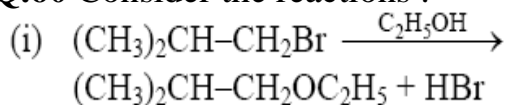

The mechanisms of reactions (i) and (ii) are respectively :

- (1) $\text{S}_{\text{N}2}$ and $\text{S}_{\text{N}1}$ (2) $\text{S}_{\text{N}1}$ and $\text{S}_{\text{N}2}$
 (3) $\text{S}_{\text{N}1}$ and $\text{S}_{\text{N}1}$ (4) $\text{S}_{\text{N}2}$ and $\text{S}_{\text{N}2}$

Q.61 Examine the figure given below and select the right option giving all the four parts (a, b, c and d) correctly identified:

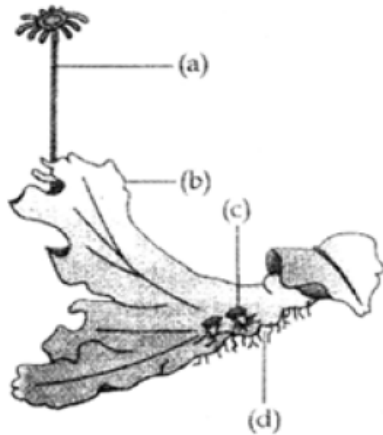

	(a)	(b)	(c)	(d)
(1)	Antherid- iophore	Male thallus	Globule	Roots
(2)	Archego- niophore	Female thallus	Gemma- cup	Rhizoids
(3)	Archego- niophore	Female thallus	Bud	Foot
(4)	Seta	Sporo- phyte	Proto- nema	Rhizoids

Q.62 *Selaginella* and *Slavinia* are considered to represent a significant step toward evolution of seed habit because :

- (1) Embryo develops in female gametophyte which is retained on parent sporophyte.
- (2) Female gametophyte is free and gets dispersed like seeds.
- (3) Female gametophyte lacks archegonia.
- (4) Megaspore possess endosperm and embryo surrounded by seed coat.

Q.63 Consider the following four statements whether they are correct or wrong

- (A) The sporophyte in liverworts is more elaborate than that in mosses
- (B) *Salvinia* is heterosporous
- (C) The life-cycle in all seed-bearing plants is diplontic
- (D) In *Pinus* male and female cones are borne on different trees

The two **wrong** statements together are :

- (1) Statements (A) and (B)
- (2) Statements (A) and (C)
- (3) Statements (A) and (D)
- (4) Statements (B) and (C)

Q.64 At metaphase, chromosomes are attached to the spindle fibres by their :

- (1) Centromere
- (2) Satellites
- (3) Secondary constrictions
- (4) Kinetochores

Q.65 Which one of the following is **not** considered as a part of the endomembrane system ?

- (1) Lysosome
- (2) Golgi complex
- (3) Peroxisome
- (4) Vacuole

Q.66 In history of biology, human genome project led to the development of :

- (1) Biosystematics
- (2) Biotechnology
- (3) Biomonitoring
- (4) Bioinformatics

Q.67 The unequivocal proof of DNA as the genetic material came from the studies on a :

- (1) Bacterial virus
- (2) Bacterium
- (3) Fungus
- (4) Viroid

Q.68 Guttation is the result of :

- (1) Root pressure
- (2) Diffusion
- (3) Transpiration
- (4) Osmosis

Q.69 Function of companion cells is :

- (1) Loading of sucrose into sieve elements
- (2) Providing energy to sieve elements for active transport
- (3) Providing water to phloem
- (4) Loading of sucrose into sieve elements by passive transport

Q.70 some vascular bundles are described as open because these :

- (1) are not surrounded by pericycle
- (2) are surrounded by pericycle but no endodermis
- (3) are capable of producing secondary xylem and phloem
- (4) possess conjunctive tissue between xylem and phloem

Q.71 Which one of the following diagrams represents the placentation in *Dianthus* ?

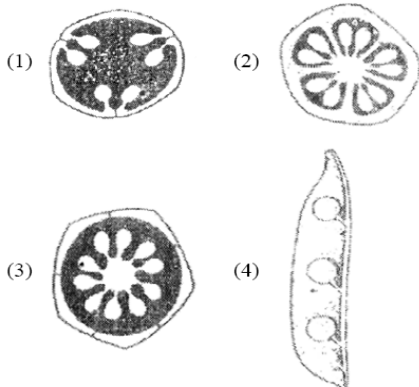

Q.72 Which one of the following is essential for photolysis of water ?

- (1) Boron
- (2) Manganese
- (3) Zinc
- (4) Copper

Q.73 In Kranz anatomy, the bundle sheath cells have :

- (1) thick walls, many intercellular spaces and few chloroplasts
- (2) thin walls, many intercellular spaces and no chloroplasts
- (3) thick walls, no intercellular spaces and large number of chloroplasts
- (4) thin walls, no intercellular spaces and several chloroplasts

Q.74 Sweet potato is homologous to :

- (1) Turnip (2) Potato
- (3) Colocasia (4) Ginger

Q.75 Which one of the following is **not** an essential mineral element for plants while the remaining three are ?

- (1) Phosphorus

- (2) Iron
- (3) Manganese
- (4) Cadmium

Q.76 Whorled, simple leaves with reticulate venation are present in :

- (1) *Alstonia*
- (2) *Calotropis*
- (3) Neem
- (4) China Rose

Q.77 What is common between vegetative reproduction and Apomixis ?

- (1) Both produces progeny identical to the parent
- (2) Both are applicable to only dicot plants
- (3) Both bypass the flowering phase
- (4) Both occur round the year

Q.78 In mitochondria, protons accumulate in the :

- (1) Matrix
- (2) Outer membrane
- (3) Inner membrane
- (4) Intermembrane space

Q.79 Which one of the following pairs is **wrongly** matched while the remaining three are correct ?

- (1) *Agave* - Bulbils
- (2) *Penicillium*- Conidia
- (3) Water hyacinth - Runner
- (4) *Bryophyllum*- Leaf buds

Q.80 In angiosperms, functional megaspore develops into :

- (1) Pollen sac
- (2) Embryo sac
- (3) Ovule
- (4) Endosperm

Q.81 Both, hydrarch and xerarch successions lead to :

- (1) Excessive wet conditions
- (2) Medium water conditions
- (3) Xeric conditions

(4) Highly dry conditions

Q.82 Which one of the following animals may occupy more than one trophic levels in the same ecosystem at the same time ?

- (1) Frog (2) Sparrow
(3) Lion (4) Goat

Q.83 The breakdown of detritus into smaller particles by earthworm is a process called :

- (1) Catabolism
(2) Humification
(3) Fragmentation
(4) Mineralisation

Q.84 "Good ozone" is found in the :

- (1) Ionosphere
(2) Mesosphere
(3) Troposphere
(4) Stratosphere

Q.85 The logistic population growth is expressed by the equation :

(1) $dN/dt = rN \left(\frac{N - K}{N} \right)$

(2) $dt/dN = Nr \left(\frac{K - N}{K} \right)$

(3) $dN/dt = rN \left(\frac{K - N}{K} \right)$

(4) $dN/dt = rN$

Q.86 Which one of the following is a **wrong** matching of a microbe and its industrial product, while the remaining three are correct ?:

- (1) *Aspergillus niger* – citric acid
(2) Yeast – statins
(3) *Acetobacter aceti* – acetic acid
(4) *Clostridium butylicum* – lactic acid

Q.87 Read the following statement having two blanks (A and B) : "A drug used for ___(A___)___ patients is obtained from a species of the organism ___(B___)___ ". The one **correct** option for the two blanks is :

Blank-A Blank-B

- (1) AIDS ' *Pseudomonas*
- (2) Heart *Penicillium*
- (3) Organ-transplant *Trichoderma*
- (4) Swine flu *Monascus*

Q.88 Common cold is not cured by antibiotics because it is :

- (1) not an infectious disease
- (2) caused by a virus
- (3) caused by a Gram-positive bacterium
- (4) caused by a Gram-negative bacterium

Q.89 Read the following four statements (A-D) about certain mistakes in two of them :

- (A) The first transgenic buffalo, Rosie produced milk which was human alpha-lactalbumin enriched.
 - (B) Restriction enzymes are used in isolation of DNA from other macro-molecules
 - (C) Downstream processing is one of the steps of R-DNA technology
 - (D) Disarmed pathogen vectors are also used in transfer of R-DNA into the host
- Which are the two statements having mistakes ?

- (1) Statements (A) and (B)
- (2) Statements (B) and (C)
- (3) Statements (C) and (D)
- (4) Statements (A) and (C)

Q.90 Silencing of mRNA has been used in producing transgenic plants resistant to :

- (1) Bacterial blights (2) Bollworms
- (3) Nematodes (4) White rusts

Q.91 Which one of the following aspects is an exclusive characteristic of living things ?

- (1) Increase in mass by accumulation of material both on surface as well as internally
- (2) Isolated metabolic reactions occur in vitro
- (3) Increase in mass from inside only
- (4) Perception of events happening in the environment and their memory

Q.92 The type of muscles present in our :

- (1) upper arm are smooth muscle fibres fusiform in shape
- (2) heart are involuntary and unstriated smooth muscles
- (3) intestine are striated and involuntary
- (4) Thigh is striated and voluntary

Q.93 The figure shows four animals (a), (b), (c) and (d). Select the correct answer with respect to a common characteristics of two of these animals.

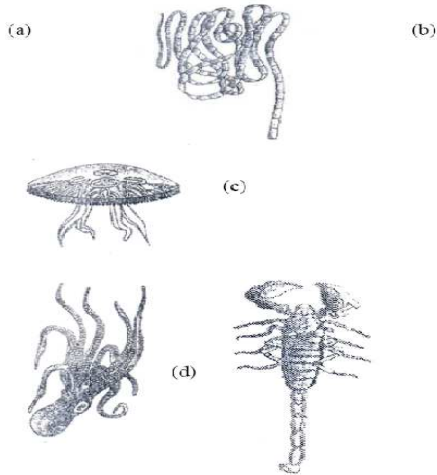

- (1) (c) and (d) have a true coelom
- (2) (a) and (d) respire mainly through body wall
- (3) (b) and (c) show radial symmetry
- (4) (a) and (b) have cnidoblasts for selfdefence

Q.94 Which one of the following conditions of the zygotic cell would lead to the birth of a normal human female child ?

- (1) one X and one Y chromosome
- (2) two X chromosomes
- (3) only one Y chromosome
- (4) only one X chromosome

Q.95 Test cross in plants or in *Drosophila* involves crossing :

- (1) between two genotypes with dominant trait
- (2) between two genotypes with recessive trait
- (3) between two F1 hybrids
- (4) the F1 hybrid with a double recessive genotype

Q.96 Which one of the following **correctly** represents the normal adult human dental formula ?

- (1) $\frac{3}{3}, \frac{1}{1}, \frac{3}{3}, \frac{3}{3}$ (2) $\frac{3}{3}, \frac{1}{1}, \frac{3}{2}, \frac{1}{1}$
- (3) $\frac{2}{2}, \frac{1}{1}, \frac{3}{2}, \frac{3}{3}$ (4) $\frac{2}{2}, \frac{1}{1}, \frac{2}{2}, \frac{3}{3}$

Q.97 The figure below shows the structure of a mitochondrion with its four parts labelled (A), (B), (C). and (D) Select the part correctly matched with its function. –

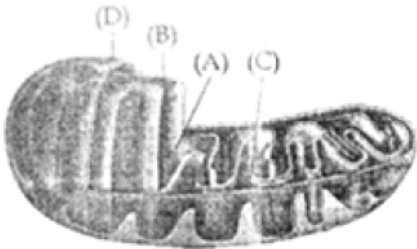

- (1) Part (A) : Matrix – major site for respiratory chain enzymes
 (2) Part (D) : Outer membrane – gives rise to inner membrane by splitting
 (3) Part (B) : Inner membrane – forms infoldings called cristae
 (4) Part (C) : Cristae – possess single circular DNA molecule and ribosome

Q.98 Bulk of carbon dioxide (CO₂) released from body tissues into the blood is present as :

- (1) carbamino-haemoglobin in RBCs
 (2) bicarbonate in blood plasma and RBCs
 (3) Free CO₂ in blood plasma
 (4) 70% carbamino-haemoglobin and 30% as bicarbonate

Q.99 Given below is the ECG of a normal human. Which one of its components is correctly interpreted below ?

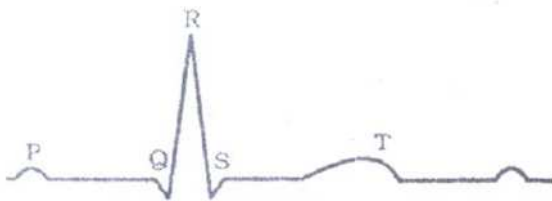

- (1) Peak P-Initiation of left atrial contraction only
- (2) Complex QRS-One complete pulse
- (3) Peak T-Initiation of total cardiac contraction
- (4) Peak P and Peak R together-systolic and diastolic blood pressures

Q.100 Frogs differ from humans in possessing :

- (1) thyroid as well as parathyroid
- (2) paired cerebral hemispheres
- (3) hepatic portal system
- (4) nucleated red blood cells

Q.101 The cells lining the blood vessels belongs to the category of :

- (1) Connective tissue
- (2) Smooth muscle tissue
- (3) Squamous epithelium
- (4) Columnar epithelium

Q.102 The 24 hour (diurnal) rhythm of our body such as the sleep-wake cycle is regulated by the hormone :

- (1) melatonin
- (2) calcitonin
- (3) prolactin
- (4) adrenaline

Q.103 Three of the following pairs of the human skeletal parts are correctly matched with their respective inclusive skeletal category and one pair is not matched. Identify the **non-matching** pair.

	Pairs of skeletal parts	Category
(1)	Malleus and stapes	Ear ossicles
(2)	Sternum and Ribs	Axial skeleton
(3)	Clavicle and Glenoid cavity	Pelvic girdle
(4)	Humerus and ulna	Appendicular skeleton

Q.104 Which one of the following structure in pheretima is **correctly** matched with its function ?

- (1) Typhlosole-storage of extra nutrients
- (2) Clitellum-secretes cocoon
- (3) Gizzard-absorbs digested food
- (4) Setae-defence against predators

Q.105 Ureters act as urinogenital ducts in :

- (1) frog's males
- (2) human males
- (3) human females
- (4) frog's both males and females

Q.106 One of the constituents of the pancreatic juice while poured into the duodenum in humans is :

- (1) Enterokinase
- (2) Trypsinogen
- (3) Chymotrypsin
- (4) Trypsin

Q.107 Which one of the following is a possibility for most of us in regard to breathing , by making a conscious effort ?

- (1) The lungs can be made fully empty by forcefully breathings out all air from them
- (2) One can breathe out air totally without oxygen
- (3) One can breathe out air through Eustachian tubes by closing both the nose and the mouth.
- (4) one can consciously breathe in and breathe out by moving the diaphragm alone, without moving the ribs at all.

Q.108 What happens during fertilisation in humans after many sperms reach close to the ovum ?

- (1) Only two sperms nearest the ovum penetrate zonapellucida
- (2) Secretions of acrosome helps one sperm enter cytoplasm of ovum through zonapellucida
- (3) All sperms except the one nearest to the ovum lose their tails
- (4) Cells of corona radiate trap all the sperms except one.

Q.109 The technique called gamete intrafallopian transfer (GIFT) is recommended for those females :

- (1) who cannot provide suitable environment for fertilisation
- (2) who cannot produce an ovum
- (3) who cannot retain the foetus inside uterus
- (4) whose cervical canal is too narrow to allow passage for the sperms

Q.110 Consider the following four statements (A-D) related to the common frog *Ranatigrina*, and select the correct option stating which ones are **true(T)** and which ones are **false(F)**.

Statements :

(A) On dry land it would die due to lack of O₂ if its mouth is forcibly kept closed for a few days

(B) it has four-chambered heart

(C) On dry land it turns uricotelic from ureotelic

(D) Its life-history is carried out in pond water

(A) (B) (C) (D)

(1) F T T F

(2) T F F T

(3) T T F F

(4) F F T T

Q.111 About which day in a normal human menstrual cycle does rapid secretion of LH (popularly called LH-surge) normally occur ?

(1) 11th day (2) 14th day

(3) 20th day (4) 5th day

Q.112 Consider the following statements (A)-(D) each with one or two blanks :

(A) Bears go into ____(_1_)____ during winter to ____(_2_)____ cold weather.

(B) A conical age pyramid with a broad base represents ____(_3_)____ human population.

(C) A wasp pollinating a fig flower is an example of ____(_4_)____ .

(D) An area with high levels of species richness is known as ____(_5_)____ .

Which of the following options, gives the correct fill ups for the respective **blank numbers** from

(1) to (5) in the statements ?

(1) (1) - hibernation, (2) - escape,

(3) - expanding, (5) - hot spot

(2) (3) - stable, (4) - commensalism,

- (5) - marsh
 (3) (1) - aestivation, (2) - escape,
 (3) - stable, (4) – mutualism
 (4) (3) - expanding, (4) - commensalism,
 (5) - biodiversity park

Q.113 Consider the following statements (A-D) about organic farming :

- (A) Utilizes genetically modified crops like Bt cotton
 (B) Uses only naturally produced inputs like compost
 (C) Does not use pesticides and urea
 (D) Produces vegetables rich in vitamins and minerals

Which of the above statements are **correct** ?

- (1) (A) and (B) only (2) (B), (C) and (D)
 (3) (C) and (D) only (4) (B) and (C) only

Q.114 Biodiversity of a geographical region represents :

- (1) Species endemic to the region
 (2) Endangered species found in the region
 (3) The diversity in the organisms living in the region
 (4) Genetic diversity present in the dominant species of the region.

Q.115 Which one of the following options gives the **correct** matching of a disease with its causative organism and mode of infection :

	Disease	Causative Organisms	Mode of Infection
(1)	Malaria	<i>Plasmodium vivax</i>	Bite of male <i>Anopheles</i> mosquito
(2)	Typhoid	<i>Salmonella typhi</i>	With inspired air
(3)	Pneumonia	<i>Streptococcus pneumoniae</i>	Droplet infection
(4)	Elephantiasis	<i>Wuchereria bancrofti</i>	With infected water and food

Q.116 The pathogen *Microsporidium* responsible for ringworm disease in humans belongs to the same Kingdom of organisms as that of :

- (1) *Ascaris*, a round worm
 (2) *Taenia*, a tapeworm

- (3) *Wuchereria*, a filarial worm
- (4) *Rhizopus*, a mould

Q.117 Select the **correct** statement with respect to disease and immunisation :

- (1) Injection of snake antivenom against snake bite is an example of active immunisation.
- (2) If due to some reason B-and T-lymphocytes are damaged, the body will not produce antibodies against a pathogen.
- (3) Injection of dead/inactivated pathogens causes passive immunity
- (4) Certain protozoans have been used to mass produces hepatitis B vaccine

Q.118 *Bacillus thuringiensis* forms protein crystals which contain insecticidal protein.

This protein :

- (1) does not kill the carrier bacterium which is itself resistant to this toxin
- (2) binds with epithelial cells of midgut of the insect pest ultimately killing it
- (3) is coded by several genes including the gene cry
- (4) is activated by acid pH of the foregut of the insect pest.

Q.119 Which one of the following techniques made it possible to genetically engineer living organisms ?

- (1) Hybridization
- (2) Recombinant DNA techniques
- (3) X-ray diffraction
- (4) Heavier isotope labeling

Q.120 Which one of the following statements is **totally wrong** about the occurrence of *notochord*, while the other three are correct ?

- (1) It is present throughout life in *Amphioxus*
- (2) It is present only in larval tail in Ascidians
- (3) It is replaced by vertebral column in adult frog
- (4) It is absent throughout life in humans from the very beginning.