

ENGINEERING SERVICES  
EXAMINATION-2013

Serial No. [ ]

A-FRF-M-LBA

**MECHANICAL ENGINEERING**

**Paper—I**  
**(Conventional)**

Time Allowed : Three Hours

Maximum Marks : 200

**INSTRUCTIONS**

*Please read each of the following instructions carefully before attempting questions.*

*Candidates should attempt FIVE questions in all. Question No. 1 is compulsory. Out of the remaining SIX questions attempt any FOUR.*

*All questions carry equal marks. The number of marks carried by a part of a question is indicated against it.*

*Answers must be written in ENGLISH only.*

*Assume suitable data, if necessary and indicate the same clearly. For air,  $R = 0.287 \text{ kJ/kg-K}$ ,  $C_p = 1.005 \text{ kJ/kg-K}$ ,  $\gamma = 1.4$ ,  $M = 28.966 \text{ kg/kg-mole}$ .*

*Unless otherwise mentioned, symbols and notations have their usual standard meanings.*

*Neat sketches may be drawn, wherever required.*

*All parts and sub-parts of a question are to be attempted together in the answer book.*

*Any pages left blank in the answer book must be clearly struck out.*

1. (a) Liquified Petroleum Gas (LPG) is sold in small cylinders for use as cooking gas. If one LPG cylinder contains 15 kg gas, express the quantity of gas contained in the cylinder in moles. Treat LPG as Butane ( $C_4H_{10}$ ) only. 5
- (b) A heat engine operates between a source at  $550^\circ C$  and a sink at  $25^\circ C$ . If the heat is supplied to the heat engine at a steady rate of 1200 kJ/min, determine the maximum power output of this heat engine in kW. 5
- (c) Explain the effect of combustion chamber shape and location of spark plug on detonation in an S.I. engine. 5
- (d) Specify the conventional and alternative refrigerants for the following applications :
- (i) Domestic refrigerators and
- (ii) Central Air-conditioning plants. 5
- (e) Discuss the various factors affecting boundary layer thickness. 5
- (f) If it is possible to describe a turbulent flow by the equation :
- $$u = 5 + 0.5 \sin t,$$
- then, calculate :
- (i)  $\overline{u'}$  and
- (ii)  $(\overline{u'^2})^{1/2}$  5

- (g) Write expression for hydraulic efficiency of a water turbine. How does the efficiency vary with part load ? 5
- (h) Explain the terms slip and slip factor, as applied to centrifugal compressor. Write expressions for these terms. 5
2. (a) A spherical balloon of 1 m diameter contains a gas at 200 kPa and 300 K. The gas inside the balloon is heated until the pressure reaches 500 kPa. During the process of heating, the pressure is proportional to the diameter of the balloon. Determine the work done by the gas inside the balloon. 10
- (b) A gas turbine engine with regeneration operates with two stages of compression and two stages of expansion. The pressure ratio across each stage of compressor and turbine is 3.5. The air enters each stage of the compressor at 300 K and each stage of the turbine at 1200 K. The compressor and turbine efficiencies are 78 and 86 percent, respectively. The effectiveness of the regenerator is 72 percent. Determine the back work ratio and the thermal efficiency of the cycle, assuming constant specific heats for air at room temperature. 20

(c) Derive expressions for  $\Delta u$ ,  $\Delta h$  and  $\Delta s$  for a gas that obeys the van der Waals equation of state for an isothermal process. 10

3. (a) An ammonia ice plant operates between a condenser temperature of  $35^\circ\text{C}$  and an evaporator temperature of  $-15^\circ\text{C}$ . It produces 10 tons of ice per day from water at  $32^\circ\text{C}$  to ice at  $-3^\circ\text{C}$ . Assuming simple saturation cycle, determine :

- (i) the capacity of the refrigeration plant.
- (ii) the mass flow rate of refrigerant.
- (iii) the compressor cylinder diameter and stroke if its volumetric efficiency is 70%, rpm = 1250 and stroke to bore ratio is = 1.3.
- (iv) the power of the compressor motor if the adiabatic efficiency of the compressor = 0.86 and mechanical efficiency = 0.94.
- (v) the theoretical and actual COP.

Assume latent heat of ice = 335 kJ/kg

Specific heat of water = 4.1868 kJ/kgK

Specific heat of ice = 1.94 kJ/kgK.

The properties of  $\text{NH}_3$  are given below :

T ( $^\circ\text{C}$ )	$v_f \times 10^3$ ( $\text{m}^3/\text{kg}$ )	$v_g$ ( $\text{m}^3/\text{kg}$ )	$h_f$ (kJ/kg)	$h_g$ (kJ/kg)	$s_f$ (kJ/kg-K)	$s_g$ (kJ/kg-K)
-15	1.52	0.508	131.3	1443.9	0.7426	5.8223
35	1.7	0.096	366.1	1488.6	1.566	5.2086

Average specific heat of ammonia vapour is 2.2 kJ/kg-K. 20

- (b) In an oil engine, working on dual combustion cycle the temperature and pressure at the beginning of compression are  $90^{\circ}\text{C}$  and 1 bar. The compression ratio is 13 : 1. The heat supplied per kg of air is 1675 kJ, half of which is supplied at constant volume and half at constant pressure. Calculate (i) the maximum pressure in the cycle, and (ii) the percentage of stroke at which cut-off occurs.

Take  $\gamma$  for compression 1.4,  $R = 0.287$  kJ/kgK and  $C_v$  for products of combustion is  $0.71 + 20 \times 10^{-5} T$  where  $T$  is in K. 10

- (c) Explain using psychrometric chart, the process of mixing of two air streams with condensation. 10

4. (a) Consider a solid sphere of radius  $R$ , the surface of which is maintained at  $t_s$ . If the sphere has a uniform internal heat generation rate of  $q^*$  per unit volume, derive expressions for the temperature distribution in the sphere and the temperature at the sphere center. Take the thermal conductivity to be constant. 15

- (b) A heat exchanger tube with inner and outer diameters 2.118 cm and 2.54 cm respectively is equipped with 20 equally spaced straight fins of uniform thickness placed longitudinally along the tube. The fins are 2.5 cm long in the radial direction and are 0.16 cm thick. Both the tube and the fins are made of steel with  $k = 45$  W/m. $^{\circ}\text{C}$ . The inside and outside heat transfer coefficients are 1130 and 255 W/m $^2$ . $^{\circ}\text{C}$ , respectively. What is the

overall heat transfer coefficient for the exchanger based on the outer exposed surface area ? Compare this result with that for the same tube without fins, subjected to the same heat transfer coefficients. 15

- (c) Find the shape factor  $F_{1-2}$  for the configuration shown in the figure. 10

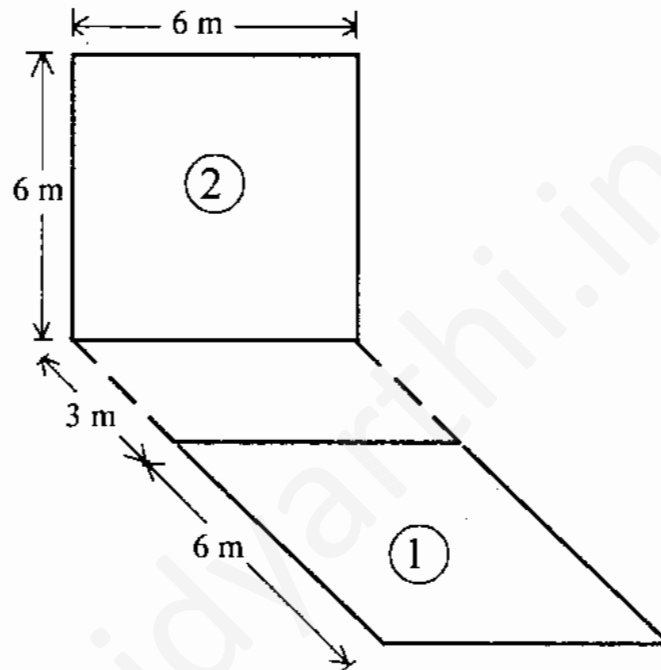

5. (a) Find the expression for the thrust  $F$  on the propeller of a ship. This thrust will be a function of mass density  $\rho$  and dynamic viscosity  $\mu$  of the liquid and diameter  $d$ , speed of advance  $v$  and rotational speed  $n$  of the propeller. 15
- (b) A smooth flat rectangular plate is placed edgewise in a stream of fluid. At what fraction of the length from the leading edge would the drag force on the front portion be equal to half of the total drag force ? Assume the boundary layer to be laminar. 10

(c) Derive an expression for the work done per second by water on the runner of Pelton turbine. Prove that for a given jet speed, volume flow rate, turning angle and wheel radius the maximum efficiency occurs when the turbine bucket moves at half the jet speed. 15

6. (a) A pitot-static tube is inserted into an airstream of velocity  $U_o$ , pressure  $1.02 \times 10^5 \text{ Nm}^{-2}$  and temperature  $28^\circ\text{C}$ . It is connected differentially to a mercury U-tube manometer. Calculate the difference of mercury levels in the two limbs of the manometer if the velocity  $U_o$  is :
- (i)  $50 \text{ ms}^{-1}$  and (ii)  $420 \text{ ms}^{-1}$ .

Take the specific gravity of mercury as 13.6 and for air  $\gamma = 1.4$ ,  $R = 0.287 \text{ kJkg}^{-1}\text{K}^{-1}$ . 15

- (b) It is required to convey  $10 \text{ m}^3/\text{s}$  of water at a mean velocity of  $1.25 \text{ m/s}$ . Calculate the dimensions of the most efficient section of the following :
- (i) rectangular  
(ii) triangular  
(iii) trapezoidal and  
(iv) circular.

Which of these has/have the least perimeter and the longest perimeter ? 15

- (c) Derive an expression for area velocity relationship for a compressible fluid in the form :

$$\frac{dA}{A} = \frac{dV}{V} (M^2 - 1).$$

Further, explain the variation of velocity with change in area for :

- (i) subsonic velocity
- (ii) sonic velocity and
- (iii) supersonic velocity. 10

7. (a) An axial flow compressor has an overall pressure ratio of 4.0 and mass flow of 160 kg/min. If the polytropic efficiency is 0.88 and stagnation pressure rise per stage must not exceed 25°C, calculate the number of stages required and the pressure ratio of the first and last stage. Assume equal temperature rise in all stages. If the absolute velocity approaching the last rotor is 155 m/s at an angle of 20° from the axial direction, the work done factor is 0.83, the velocity diagram is symmetrical and the mean diameter of the last stage rotor is 180 mm, compute the rotational speed and the length of the last stage. Ambient conditions are 1.01 bar and 288 K. 25

- (b) What are the essentials of a good steam boiler ? Enumerate the factors which should be considered while selecting a boiler. 15