

# Exploring Some Geometric Themes Class 8 Solutions

## Maths Ganita Prakash Part 2 Chapter 4

---

### 4.1 Fractals

#### Figure It Out (Page 72)

##### Question 1.

Draw the initial few steps (at least till Step 2) of the shape sequence that leads to the Sierpinski Triangle.

**Solution:**

**Step 0:** Take cut out of an equilateral triangle  $\Delta$ .

**Step 1:** Divide it into 4 equilateral triangles by joining the midpoints of each of the sides. Remove the central triangle.



**Step 2:** Divide each of the remaining 3 equilateral triangles into four equilateral triangles and remove the central triangle in each of them.



**Step 3:** Repeat the steps again and again to get Sierpinski's gasket.



### Question 2.

Find the number of holes and the triangles that remain at each step of the shape sequence that leads to the Sierpinski Triangle.

**Solution:**

**Number of holes in**

**Step 0:** 0 hole

**Step 1:** 1 hole

**Step 2:**  $1 + 3 = 4$  holes

**Step 3:**  $1 + 3 + 9 = 13$  holes

**Step 4:**  $1 + 3 + 9 + 27 = 40$  holes

.

.

.

$$\text{Step } n: 3^{1-1} + 3^{2-1} + 3^{3-1} + \dots + 3^{n-1} \text{ holes}$$
$$3^0 + 3^1 + 3^2 + \dots + 3^{n-1} \text{ holes}$$

### Question 3.

Find the area of the region remaining at the  $n$ th step in each of the shape sequences that lead to the Sierpinski fractals. Take the area of the starting square/triangle to be 1 sq. unit.

**Solution:**

**(a) Let the side of the square of Sierpinski's Carpet be 1 square unit.**

As one-ninth of the square is removed, and one-eighth remains in each step.

**Step 0:** Area of whole square =  $(1)^2 = 1$

**Step 1:** Area of remaining region =  $\frac{8}{9}(1)^2 = \frac{8}{9}$

**Step 2:** Area of remaining region =  $\frac{8}{9} \times \frac{8}{9} = \frac{64}{81}$

**Step 3:** Area of remaining region =  $\frac{8}{9} \times \frac{64}{81} = \frac{8^3}{9^3} = \frac{512}{729}$

Area of remaining region after  $n$ th step =  $\left(\frac{8}{9}\right)^n$  sq. units

**(b) Let the area of the triangle of Sierpinski's Gasket be 1 square unit.**

One-fourth of the triangle is removed in each step, and three-fourth remains.

**Step 0:** Area of the whole triangle = 1 sq. unit.

**Step 1:** Area of remaining region =  $\frac{3}{4}$  sq. units.

**Step 2:** Area of remaining region =  $\frac{3}{4} \times \frac{3}{4}$  square units =  $\frac{9}{16}$  sq. units

Area of remaining region after  $n$ th step =  $\left(\frac{3}{4}\right)^n$  sq. units

### Figure It Out (Page 73)

#### Question 1.

Draw the initial few steps (at least till Step 2) of the shape sequence that leads to the Koch Snowflake.

**Solution:**



**Question 2.**

**Find the number of sides in the  $n$ th step of the shape sequence that leads to the Koch Snowflake.**

**Solution:**

**Number of sides:**

**Step 0:** 3

**Step 1:**  $3 \times 4 = 12$

**Step 2:**  $3 \times 4^2 = 48$

**Step 3:**  $3 \times 4^3 = 192$

.

.

.

**Step  $n$ :**  $3 \times 4^n$

**Question 3.**

**Find the perimeter of the shape at the  $n$ th step of the sequence. Take the equilateral triangle to have a side length of 1 unit.**

**Solution:**

**Perimeter of Koch Snowflake**

**Step 0:** 3 units

**Step 1:**  $3 \times \left(\frac{4}{3}\right)^1$  units

**Step 2:**  $3 \times \left(\frac{4}{3}\right)^2$  units

**Step 3:**  $3 \times \left(\frac{4}{3}\right)^3$  units

**Step 4:**  $3 \times \left(\frac{4}{3}\right)^4$  units

.

.

Step n:  $3 \times \left(\frac{4}{3}\right)^n$  units.

Perimeter of step n =  $3\left(\frac{4}{3}\right)^n$  units.

## 4.2 Visualising Solids

### Intext Questions (Pages 75-77)

#### Question 2.

Cut off the four corners of an imaginary square, with each cut going between midpoints of adjacent edges. What shape is left over? How can you reassemble the four corners to make another square? (Page 76)

**Solution:**

ABCD is a square.

P, Q, R, and S are midpoints of AB, BC, CD, and AD, respectively.

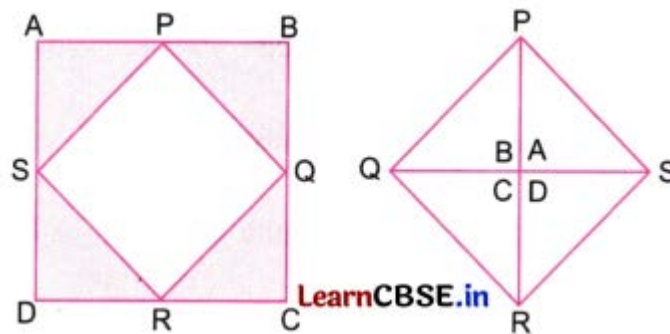

When we cut along PQ, QR, RS, and PS, we again get a square.

If we join the shaded portions again, we get a square of the same size as that of PQRS.

#### Question 3.

Mark the sides of an equilateral triangle into thirds. Cut off each corner of the triangle, as far as the marks. What shape do you get? (Page 76)

**Solution:**

XYZ is an equilateral triangle with  $XY = YZ = ZX$ .

Divide each side into 3 equal parts as shown.

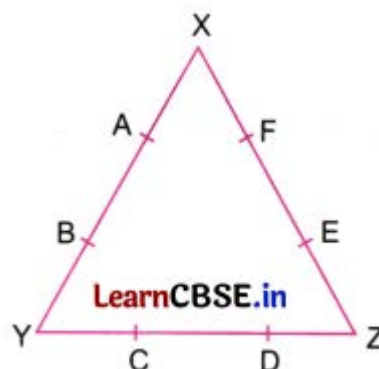

We note  $XA = AB = BY = YC = CD = DZ = ZE = EF = FX$   
 Join  $AF$ ,  $BC$ ,  $ED$ .

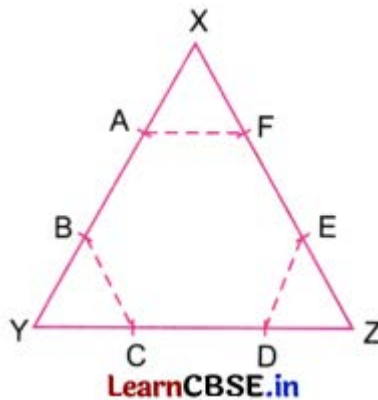

Shape  $ABCDEF$  is a hexagon.  
 As all sides of the hexagon are equal, it is called regular hexagon.

**Question 4.**

**Mark the sides of a square into thirds and cut off each of its corners as far as the marks. What shape is left? (Page 76)**

**Solution:**

$KLMN$  is a square.  
 Each side of the square is divided into three equal parts.



When the four corners of the square are cut off, we get an octagon.

Can you describe a solid and a viewpoint that would result in each of the following cases? If it helps, you can imagine the solid passing through a wall like Tom did, and leaving a hole of the appropriate shape. (Page 77)

**Question 5.**

**A solid whose profile has a square outline.**

**Solution:**

A solid with a profile that has a square outline is a CUBE.

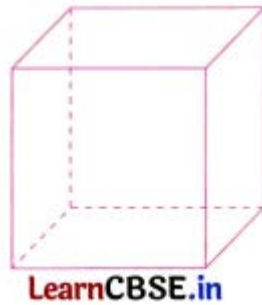

**Question 6.**

**A solid whose profile has a circular outline.**

**Solution:**

A solid whose profile has a circular outline is a sphere.

**Question 7.**

**A solid whose profile has a triangular outline.**

**Solution:**

A solid whose profile has a triangular outline is a triangular pyramid.



As we saw with the elephant, a given solid might have very different profiles from different viewpoints. Can you visualise solids that have the following contrasting profiles? Spend some time on this, and if you are finding it difficult to visualise, you may look around and use objects that are around you, or that you will make in the next section. Feel free to consider viewpoints from any direction, including directly above the object. (Page 77)

**Question 8.**

**A solid with a rectangular profile from one viewpoint and a circular profile from another viewpoint.**

**Solution:**

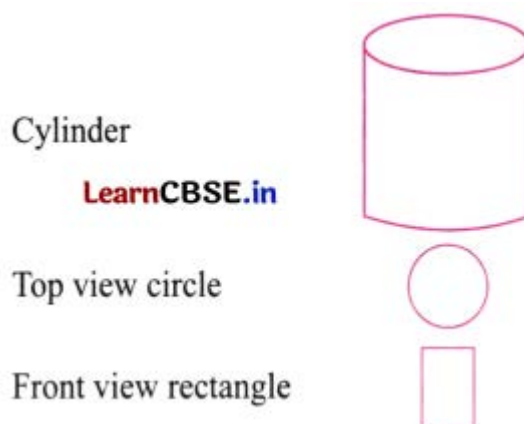

**Question 9.**

**A solid with a circular profile from one viewpoint and a triangular one from another viewpoint.**

**Solution:**

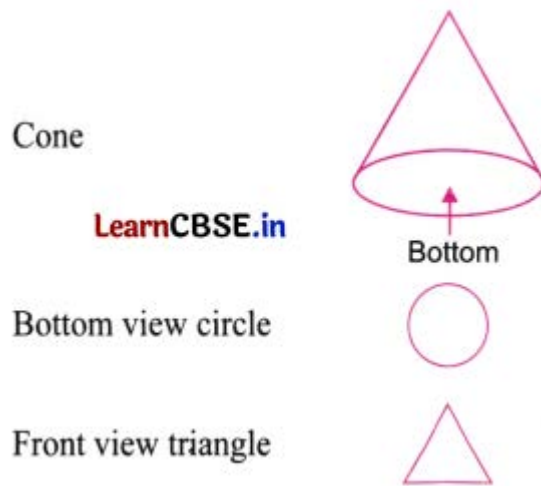

**Question 10.**

**A solid with a rectangular profile from one viewpoint and a triangular one from another viewpoint.**

**Solution:**

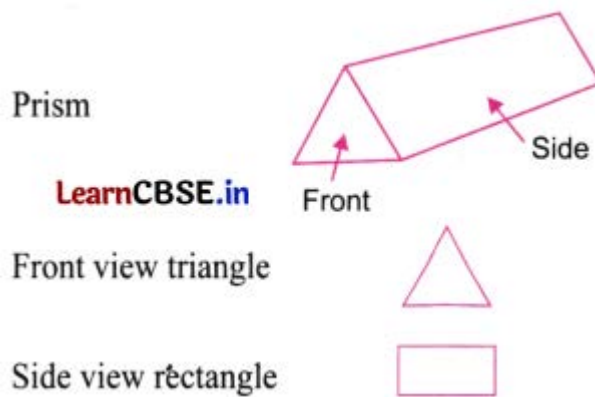

**Question 11.**

**A solid with a trapezium-shaped profile from one viewpoint and a circular one from another viewpoint.**

**Solution:**

A truncated cone or a cone cut off from a larger cone.

This shape is called a frustum.

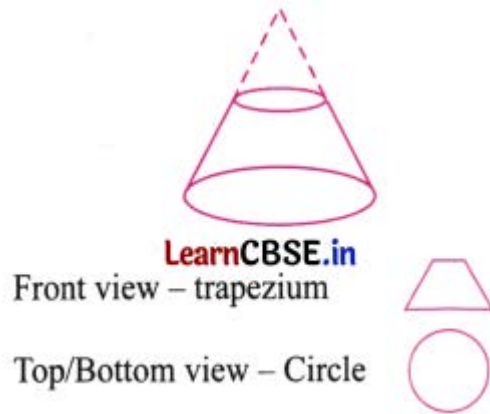

**Question 12.**

**A solid with a pentagonal profile from one viewpoint and a rectangular one from another viewpoint.**

**Solution:**

Pentagon base prism.

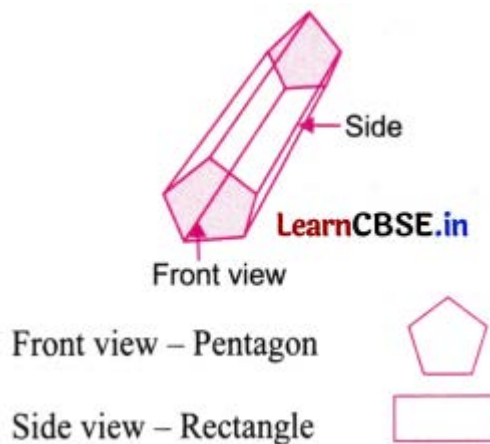

**4.3 Making Solids, 4.4 Special Solids**

**Intext Questions (Pages 79-80)**

**Question 1.**

**If the congruent polygons of a prism have 10 sides, how many faces, edges, and vertices does the prism have? What if the polygons have n sides? (Page 79)**

**Solution:**

Number of sides of a congruent polygon of a prism = 10

Number of faces =  $n + 2$

=  $10 + 2$

= 12

Number of edges =  $3 \times n$

=  $3 \times 10$

= 30

Number of vertices =  $2 \times n$

=  $2 \times 10$

= 20

A polygon with n sides will have

Number of faces =  $n + 2$

Number of edges =  $3n$

Number of vertices =  $2n$

### Question 2.

If the base of a pyramid has 10 sides, how many faces, edges, and vertices does the pyramid have? What if the base is an  $n$ -sided polygon? (Page 79)

**Solution:**

Number of sides of the base of the pyramid = 10

Number of faces =  $n + 1$

=  $10 + 1$

= 11

Number of edges =  $2n$

=  $2 \times 10$

= 20

Number of vertices =  $n + 1$

=  $10 + 1$

= 11

If the base is an  $n$ -sided polygon, then

No. of faces =  $n + 1$

No. of edges =  $2n$

No. of vertices =  $n + 1$

### Question 3.

What is a net of a cube? (Page 80)

**Solution:**

A net of a cube is a 2D arrangement of six squares that can be folded along the edges to form the cube.

It has 11 nets in all.

One of the nets is drawn below.

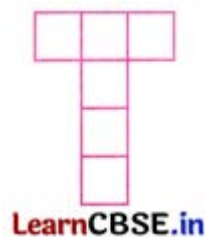

### Question 4.

Visualise how it can be folded to form a cube. (Page 80)

**Solution:**

Now we will visualise the formation of a cube from its net.

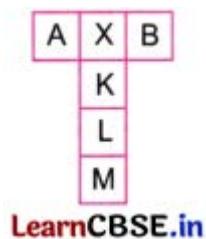

X is the base of the cube.

A and B are its left and right sides.

K is the front face, L the top, and M the back side of the cube.



### Figure It Out (Pages 80-81)

#### Question 1.

Which of the following are the nets of a cube? First, try to answer by visualisation. Then, you may use cutouts and try.

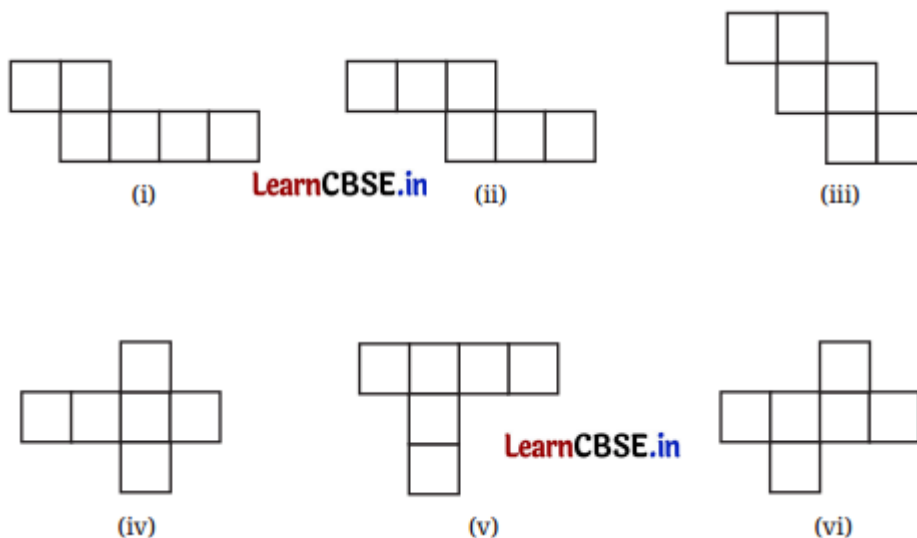

#### Solution:

- (i) No
- (ii) Yes
- (iii) Yes
- (iv) Yes
- (v) No
- (vi) Yes

**QUESTION 2.**

A cube has 11 possible net structures in total. In this count, two nets are considered the same if one can be obtained from the other by a rotation or a flip. For example, the following nets are all considered the same—

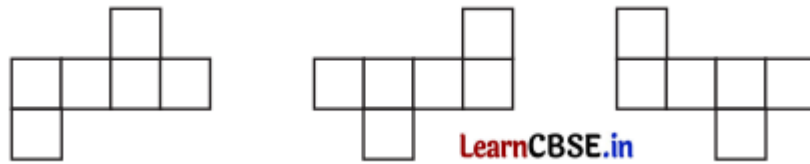

Find all the 11 nets of a cube.

Solution:

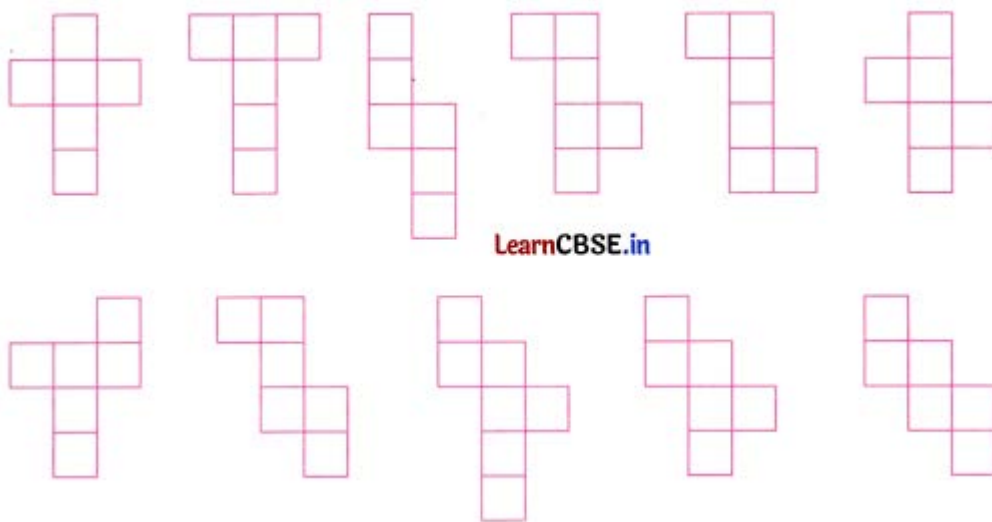

**Question 3.**

Draw a net of a cuboid having sidelengths:

(i) 5 cm, 3 cm, and 1 cm

(ii) 6 cm, 3 cm, and 2 cm

Solution:

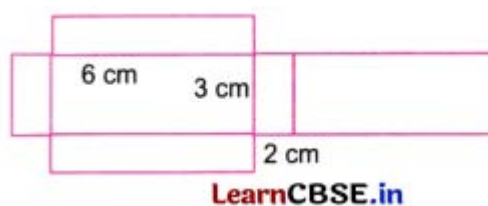
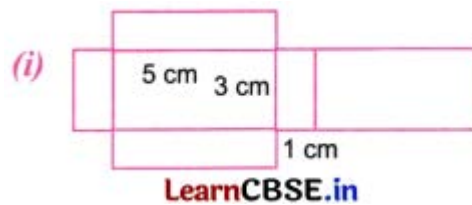

Intext Questions (Pages 81-82)

**Question 1.**

**What is a net of a regular tetrahedron? Which of the following are nets of a regular tetrahedron? (Page 81)**

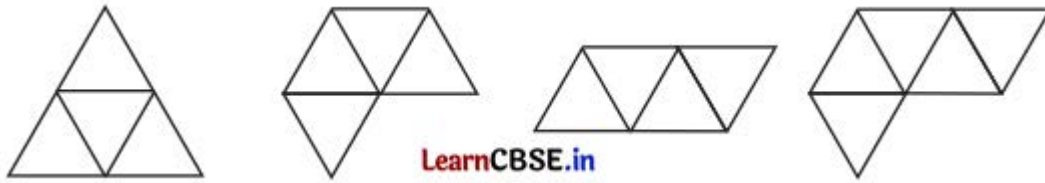

**Solution:**

(ii) and (iv) are not a net of a tetrahedron.

**Question 2.**

**Draw a net with appropriate measurements that can be folded into a regular tetrahedron. Verify if it works by making an actual cutout. (Page 81)**

**Solution:**

Draw an equilateral triangle of side length 6 cm.

Mark the midpoints of the sides of the triangle.

Join the midpoints. Fold along the dotted lines to get the tetrahedron.

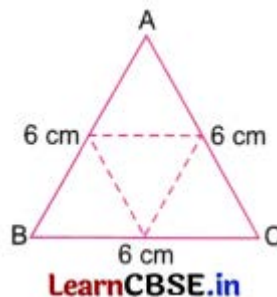

Cut out the triangle to form an actual tetrahedron.

**Question 3.**

**Draw a net with appropriate measurements that can be folded into a square pyramid. Verify if it works by making an actual cutout. (Page 81)**

**Solution:**

(a) Draw four squares of side 4 cm in a row.



(b) On the opposite edges of any of the middle two squares, draw two more squares of side 4 cm each.

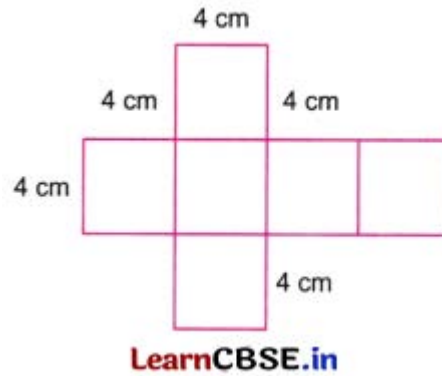

Fold along the common edges to form a cube of edge length 4 cm.

Cut along the outer boundary and fold along the common edge to form a cube.

**Question 4.**

**What is the net of a cylinder? (Page 82)**

**Solution:**

A net of a cylinder is a rectangle and two equal circles.

For the net of a cylinder, draw a circular face of radius  $r$  cm on the opposite side of a rectangle with length =  $2\pi r$  and breadth =  $h$ .

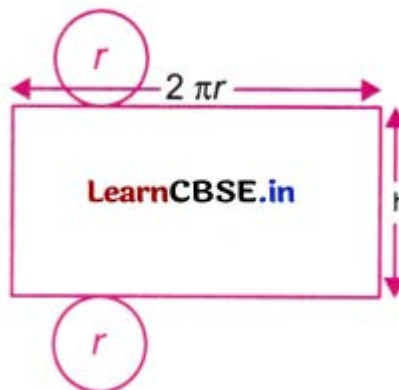

**Question 5.**

**How will the net of a cone look? (Page 82)**

**Solution:**

To make a net of a cone, draw a sector of a circle of radius  $R$  with a length of arc of the sector as  $2\pi r$  and a circle of radius  $r$  attached to the arc.

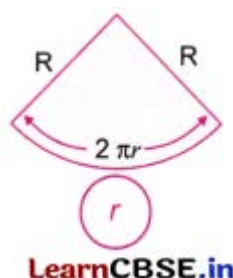

**Question 6.**

**What surface do you construct by using the above net, in which O is not the centre of the boundary circle? Make a physical model to help you answer this question! (Page 82)**

**Solution:**

When we join the radii of the sector, we get a cone:



OA and OB are radii of a circle.

Paste OA over OB, we get a cone with slant height = OA.

**Question 7.**

**Draw a net with appropriate measurements that can be folded into a triangular prism.**

**Verify that it works by making an actual cutout. (Page 82)**

**Solution:**

ABCD is a rectangle of sides 6 cm by 2 cm. DCIF and FIHG are also rectangles of the same dimensions.

DEF and CJI are equilateral triangles of side 2 cm each.

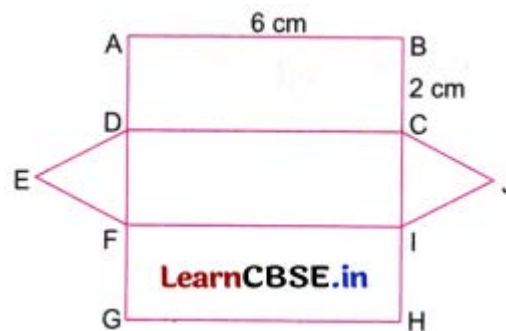

By folding along the common edges, we get a triangular prism.

**Figure It Out (Pages 92-93)**

**Question 1.**

**Observe the front view, top view, and side view of the different lines in the figure. Is there any relation between their lengths?**

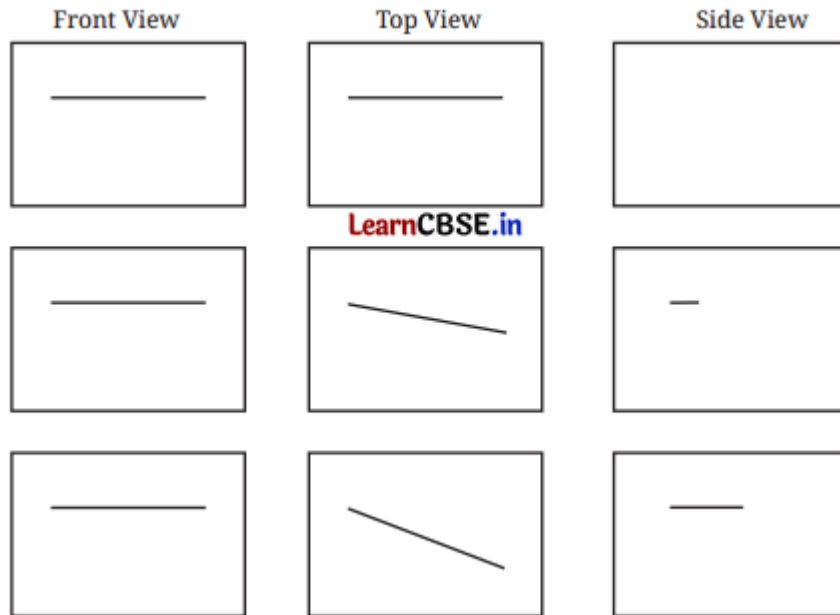

(a) Horizontal Line

(b) oblique (slanting) line

(c) oblique (slanting) line, More tilted than line (b)

Top views show that (a) is the shortest, and (c) is the longest.

**Question 2.**

Find the front view, top view, and side view of each of the following solids, fixing its orientation with respect to the vertical, horizontal, and side planes: cube, cuboid, parallelepiped, cylinder, cone, prism, and pyramid. If needed, see the next problem for clues.

**Solution:**

(a) **Cube:** Assuming standard orientation with faces parallel to planes.

View	Dimensions	Shape
Front view	$l \times l$	Square
Top view	$l \times l$	Square
Side view	$l \times l$	Square

LearnCBSE.in

(b) **Cuboid: Dimensions**

length =  $l$ , breadth =  $b$ , height =  $h$

View	Dimensions	Shape
Front view	$l \times h$	Rectangle
Top view	$l \times b$	Rectangle
Side view	$b \times h$	Rectangle

[LearnCBSE.in](http://LearnCBSE.in)

(c) Parallelepiped: All faces are parallelograms.

View	Shape
Front view	Parallelogram
Top view	Parallelogram <a href="http://LearnCBSE.in">LearnCBSE.in</a>
Side view	Parallelogram

(d) Cylinder: Axis vertical

View	Shape
Front view	Rectangle
Top view	Circle <a href="http://LearnCBSE.in">LearnCBSE.in</a>
Side view	Rectangle

(e) Cone: Axis vertical, base on horizontal plane.

View	Shape
Front view	Isosceles triangle
Top view	Circle <a href="http://LearnCBSE.in">LearnCBSE.in</a>
Side view	Isosceles triangle

(f) Prism: Regular prism with square base, axis vertical.













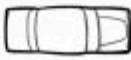







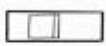











View	Shape
Front view	Rectangle
Top view	Square <a href="http://LearnCBSE.in">LearnCBSE.in</a>
Side view	Rectangle

(g) Pyramid: Square pyramid, axis vertical

View	Shape
Front view	Isosceles triangle
Top view	Square <a href="http://LearnCBSE.in">LearnCBSE.in</a>
Side view	Isosceles triangle

Question 3.

Match each of the following objects with its projections.

	FRONT	TOP	SIDE
			
			
			
			
			
			
			
			

**Solution:**

- (a) – (viii)
- (b) – (vi)
- (c) – (vii)
- (d) – (i)
- (e) – (iii)
- (f) – (iv)
- (g) – (v)
- (h) – (ii)

**Figure It Out (Pages 95-97)**

**Question 1.**

Draw the top view, front view, and side view of each of the following combinations of identical cubes.

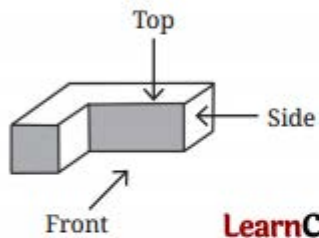
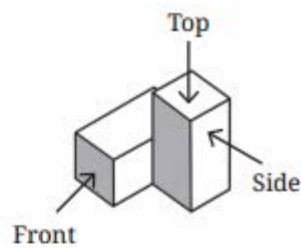
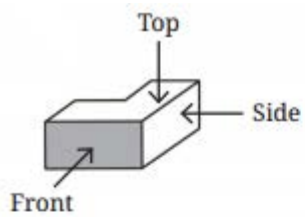

[LearnCBSE.in](http://LearnCBSE.in)

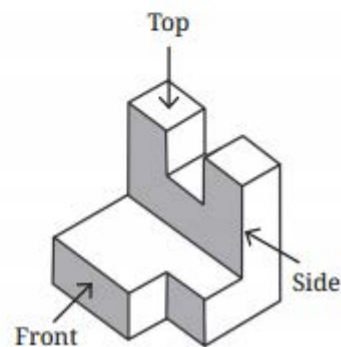
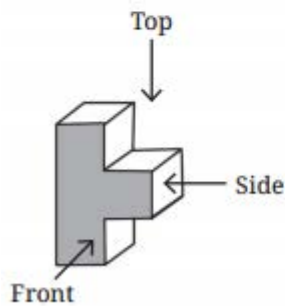
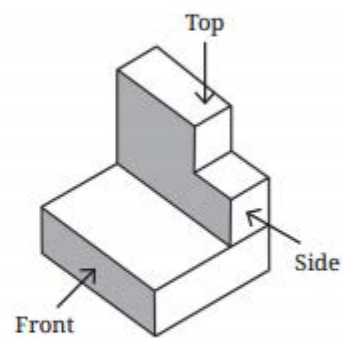

**Solution:**

	Front View	Side View	Top View
(a)			
(b)			
(c)			
(d)			
(e)			
(f)			





LearnCBSE.in

## Question 2.

Imagine eight identical cubes, glued together along faces to form the letter **E**.

- This looks like a from the front. What does it look like from the side? From the top?
- Glue additional cubes to make a shape that looks like from the front and from the top.
- Now, can you glue even more cubes to make it look like from the front, from the top, and from the side?
- Can you think of other letter combinations to make with a single combination of cubes in this manner?

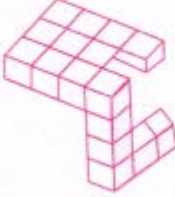
Solution:

	Side	Top
(i)		
(ii)		<a href="http://LearnCBSE.in">LearnCBSE.in</a>
(iii)	Not possible	
(iv)		

Question 3.

Which solid corresponds to the given top view, front view, and side view?

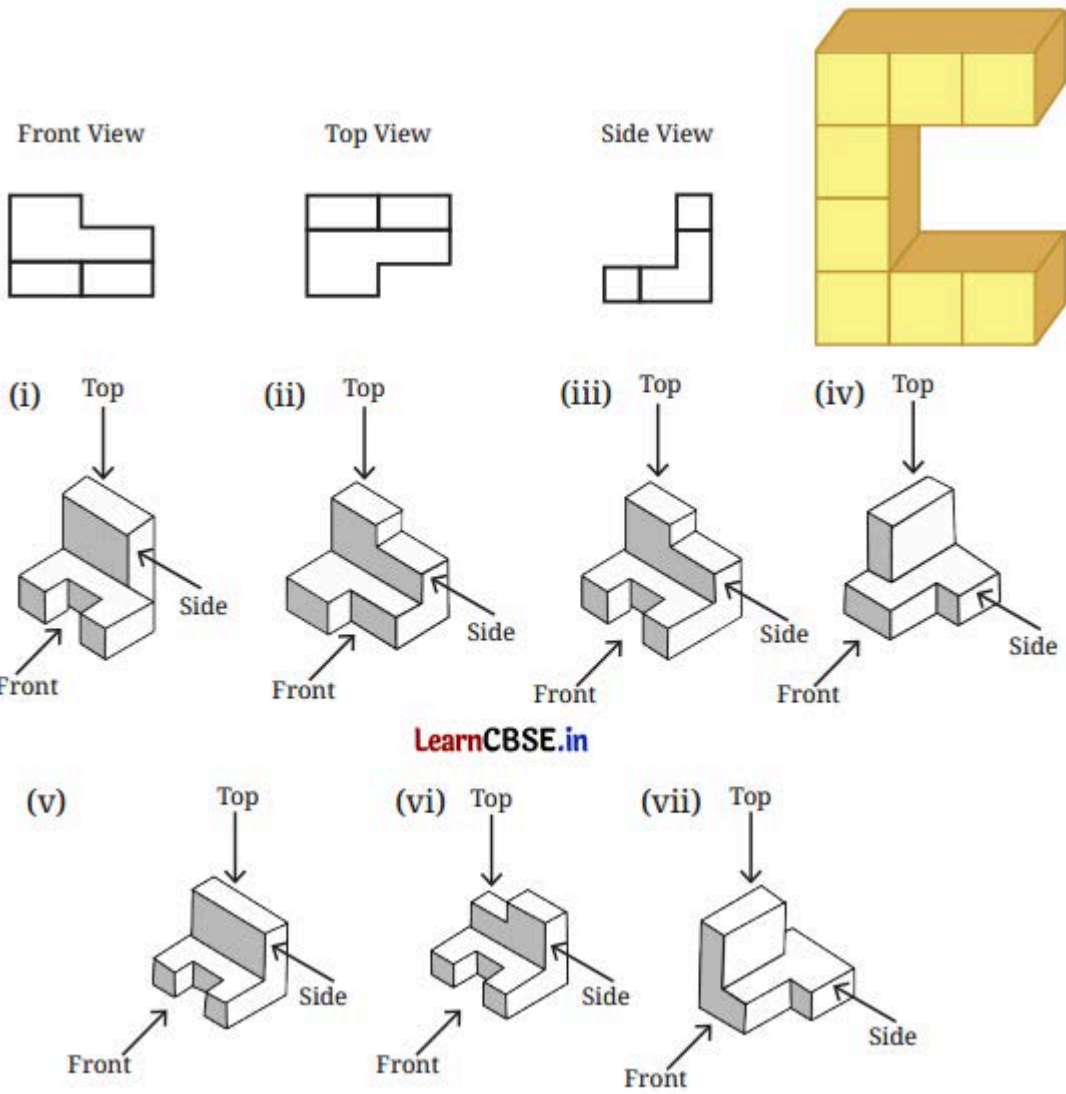

**Solution:**

Solid (ii)

**Question 4.**

Using identical cubes, make a solid that gives the following projections.

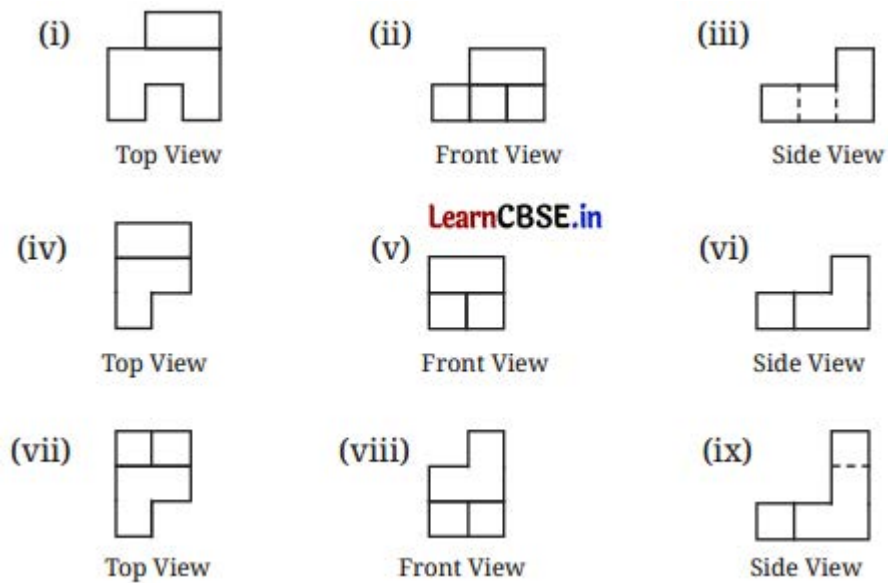

**Solution:**



**Question 5.**

**Find the number of cubes in this stack of identical cubes.**



**Solution:**

Counting from the top layer to the bottom layer:

$$1 + 3 + 6 + 10 = 20 \text{ cubes}$$

**Question 6.**

**What are the different shapes the projection of a cube can make under different orientations?**

**Solution:**

Five different shapes can be observed.

**(a) Square**

Orientation: One face of the cube is parallel to the projection plane.

**(b) Rectangle**

Orientation: Two faces are visible, but one set of edges is parallel to the plane.

**(c) Parallelogram**

Orientation: A face is tilted relative to the plane.

**(d) Rhombus**

Orientation: A special tilted case where all projected edges remain equal.

**(e) Hexagon (maximum case)**

Orientation: The cube is oriented so that three faces are equally visible (e.g., looking along a body diagonal).

**Figure It Out (Pages 100-102)**

**Question 1.**

In addition to the 5 ways shown in Fig. 4.8, are there any additional ways of gluing four cubes together along faces? Can you visualise and draw these as well? (NCERT Textbook, Page 98)

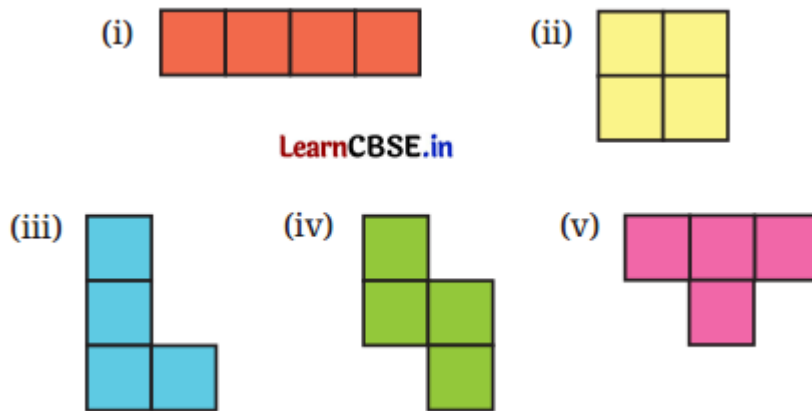

**Solution:**



**Question 2.**

Draw the following figures on the isometric grid.

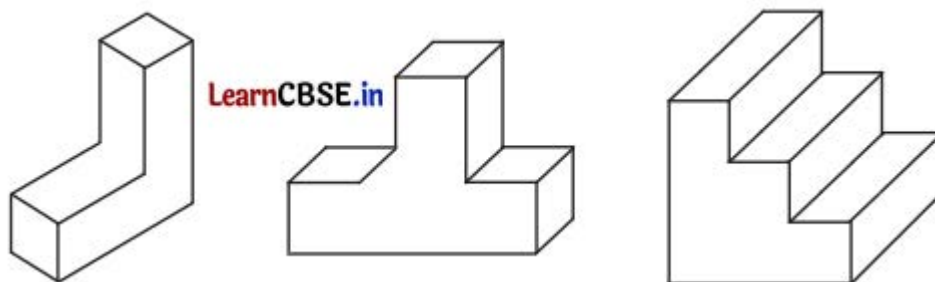

[Hint: It may be useful to determine whether the edge to be currently drawn — say, along the height — goes from down to up or up to down. Accordingly, draw the line segment on the grid either in the direction of the height axis or opposite to it.]

**Solution:**

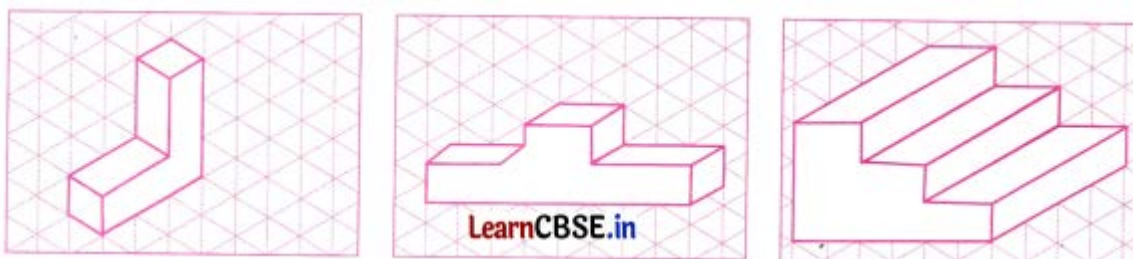

### Question 3.

Is there anything strange about the path of this ball? Recreate it on the isometric grid.



[Hint: Consider a portion of this figure that is physically realisable and identify the 3 primary directions.]

#### Solution:

The picture shows the Penrose staircase. It is an optical illusion showing a loop of stairs that appears to rise or descend forever. Each step looks locally consistent, but the structure cannot exist in reality. The illusion works by exploiting perspective and depth cues, creating the impression of continuous motion without a true beginning or end. On a Penrose staircase, a ball would have no physically possible path at all—because the staircase itself cannot exist as a single, consistent object in real 3D space. However, we can still answer the question in two ways:

- Every step appears to slope downward, yet the staircase loops back to the starting point. When the ball is released, it rolls “down” the stairs, goes around the loop, and keeps rolling forever, always downhill. This creates a perpetual-motion illusion — a never-ending descent with no lowest point.
- If we have a Penrose staircase in the real world, at least one section would slope upward or the staircase would have to twist or break. The loop would not close. So the ball would roll down until it reaches a lowest point, then stop or roll back the way it came. There is no continuous path where the ball can always go down and still return to the start.

### Question 4.

Observe this triangle.

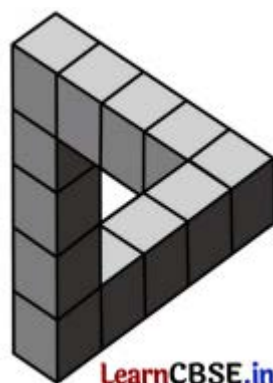

(i) Would it be possible to build a model out of actual cubes? What are the front, top, and side profiles of this impossible triangle?

(ii) Recreate this on an isometric grid.

(iii) Why does the illusion work?

**Solution:**

(i) The impossible triangle using cubes creates an optical illusion where three straight beams of square cross-section appear to form a continuous, closed loop.

It can be built using cubes of the same size in the following steps.

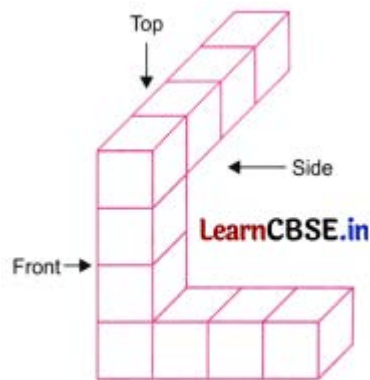

**Step 1:** Bottom Row: Lay a horizontal row of 4-5 cubes.

**Step 2:** Vertical Row: At one end, stack 4-5 cubes vertically to form a 90-degree corner.

**Step 3:** The “Gap” Row: At the top of the vertical stack, extend a row of cubes horizontally away from the viewer (into the depth of the scene)

When observed through a camera at a specific angle, the end of this third row will appear to “touch” the first horizontal row, even though they are feet apart.

Front, side, and top views are as follows.

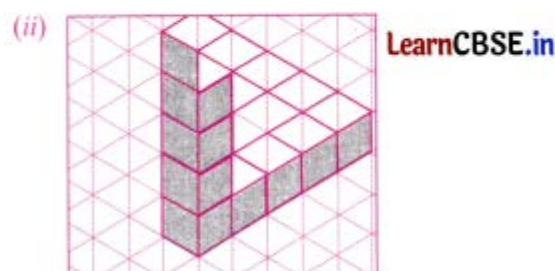
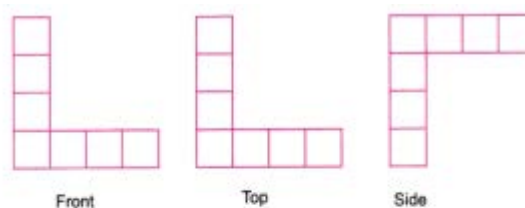

(iii) The impossible triangle works because:

- Our brain assumes a 3D structure from 2D images.

- Our brain focuses on small, local areas rather than checking the entire object for logical consistency. When we mentally “connect” the corners, the contradictions are hidden.
- Our brain doesn’t notice the switch—it keeps one depth interpretation and ignores the rest.
- Our visual system follows a principle called good continuation: it prefers smooth, continuous shapes rather than broken ones.
- So instead of seeing three separate bars that don’t line up, your brain forces them into a single triangle.